



*Level Measurement Solutions*  
for over **3** Decades

## RF LEVEL SWITCH 550



RF Level Switch is designed to provide accurate and reliable point level (High and Low Level) information of Solids (Powders and Lumps), Liquids and Slurry stored in vessels and tanks. The electronics consist of an oscillator, a detector and an output relay which is controlled by the detector. The probe contains an active section and a shield section insulated from each other and from the vessel ground. Most conventional sensors give a false indication when coated due to build up. EIP Level Sensors are designed to ignore any such build-up or coating.



APPLICATIONS : ESP Hoppers, Solid storage vessels, Liquid storage vessels, Chute Block Switch (CBS), Slurry

## ROTARY PADDLE TYPE LEVEL SWITCH



The Rotaries rotate at 3RPM and stops and actuates the Relay when material is filled. Specialized De energizing motor stops when material is present.

## VIBRATING ROD/FORK LEVEL SWITCH



Piezoelectric driven vibration level switch detects high, mid and low levels in vessels with powders and bulk solids.

## TILT LEVEL SWITCH



Suspended over a controls point with wire rope, chain or cable. After coming in contact with material the paddle tilts up to 15 degree, where in a large steel ball inside unit shifts position actuating a micro switch.

Application : High/ Low Level switch and t Solid Flow/ No Flow detector on Open/ Conveyor Belt

## DIAPHRAGM/BOOT LEVEL SWITCH



Also CALLED Pressure switch and operates by sensing material pressing against the diaphragm. Primary application in BUCKET ELEVATOR in Cement Plants to prevent jamming of cycle due to spillage and collection at the bottom. Available up to 400 degrees C

## NON CONTACT HIGH/ LOW LEVEL SWITCH AND CHUTE BLOCK SWITCH



A beam of Microwaves at 70GHz passes from a Sender to Receiver in bursts of 220 times per second. If the path is blocked by any material which absorbs or reflects microwave the chain gets broken and relay is actuated. Microwave switch can be used to cross the refractory linings as well

Application : High/ low Level switch, Stacker/ Reclaimer Boom Protection, CBS (Chute Block Switch), Anti Collision/ Machinery Positioning, Nucleonic switch replacement

## DUST DETECTOR/ PARTICULATE MONITOR/ BAGHOUSE LEAK DETECTOR



Dust Detector utilizes Tribo electric technology, whereby the collision and interaction of particles with the probe rod causes a small electrical charge transfer to occur. This small electrical charge provides a signal that is monitored by the electronics in the device. It is designed to prevent false readings, even if an accumulation of dust forms on the sensor rod.

It can be set to make pre warning indicator alerts to potentially hazardous situations or be set to provide an instantaneous alarm or one-minute averaged readings. There is a 4-20mA output for applications where Dust Detect will be used with a PLC.

## NON CONTACT RADAR LEVEL TRANSMITTER (INTEGRAL & REMOTE)



The Radar Level Meters are excellent devices for non contact level measurement. The microwave impulses, emitted by the radar's antenna, travel at speed of light and a part of their energy, reflected by the surface of the medium to be measured, is received by the same antenna. The period of time (flying time) between the emission and the arrival of the impulses, is proportional to the existing distance between the antenna and the surface of the medium to be measured.

An integrated temperature sensor compensates the temperature in real time. The Radar Level Meters can be installed both in metallic or non metallic tanks



## NON CONTACT ULTRASONIC LEVEL TRANSMITTER (INTEGRAL & REMOTE)



The ultrasonic impulses generated from transducers "antenna system", which travel at the speed of sound, come reflected by the surface of medium and newly sent back to the transducer.

The period of time that passes between the emission of impulses and the reception of the same ones from the antenna, is proportional to the existing distance between the same antenna and the higher level of the medium to measure, therefore the principle of the ultrasonic measure can be illustrated with the following equation:

$$S=CXT/2, \text{ where } S: \text{ distance, } C: \text{ velocity of sound, } T: \text{ time lapse}$$



## GUIDED WAVE RADAR



High-frequency microwave pulses transmitted by the guided wave radar propagates along the detector component (wire cable or steel bar), and are reflected on the surface of the medium. After reaching the dielectrics to be measured, part of the pulse energy is reflected. The time interval between the emission of the pulses and their arrival is proportional to the distance between the surface of the medium and the reference plan of the instrument.

The instruments have a low consumption; it can be installed on metallic or non metallic tanks. Their use is not harmful to humans or environment.



## ELECTROMECHANICAL/ SILO PILOT/ SMART BOB

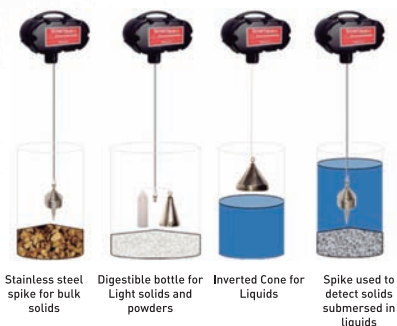

A heavy-duty motor releases a strong, stainless steel aircraft cable from the supply pulley and a weighted sensor probe quickly descends to the surface of the material. During the descent, the pulses with a high resolution micro-controlled optical sensing system are generated. When the sensor probe touches the material surface, pulses are momentarily stopped and measurement information is transmitted. The absence of pulses also causes the motor to reverse and retract the sensor probe. A second confirming measurement is taken as the probe retracts and is compared to the descend measurement

## 3D LEVEL SCANNER : ADVANCED LEVEL MEASUREMENT AND INVENTORY SOLUTIONS



**3D** Level Scanner II delivers continuous accurate measurement of bulk solids and powders regardless of the type of material or product characteristics, shape and size of storage silo, bin, container or warehouse, and harshness of the storage environment.

3D Level Scanner II employs an array of 3 antennas, each being a trans-receiver transmitting and receiving low frequency acoustic impulses. This patented design provides the scanner a very high beam angle of 30-70 degree covering the whole surface of the silo/ bin/ warehouse/ stockpile along with its unique Dust Penetrating Ability and Self Cleaning Ability

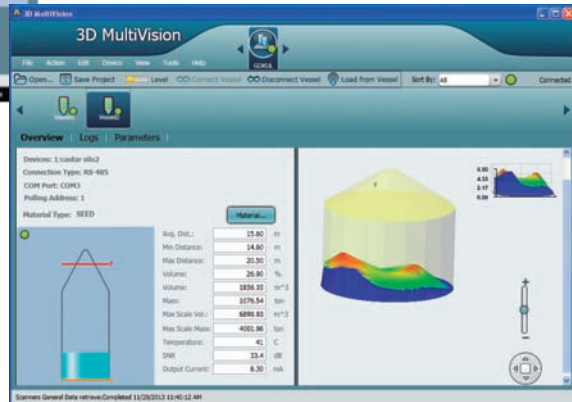
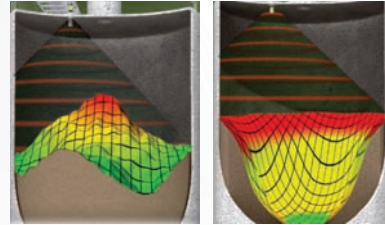
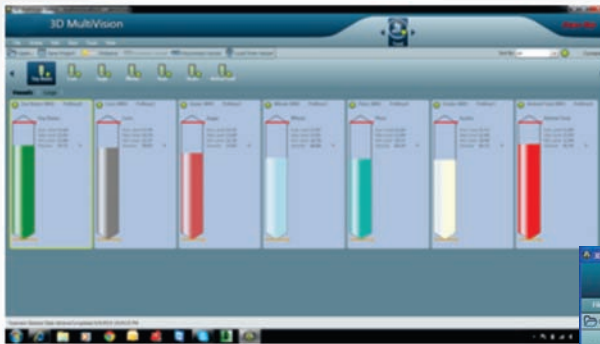

### Applications :

- Silo/ Bunker Level and Inventory Solutions for all Bulk Solids and Powder Applications
- ESP Fly Ash Hopper Management
- Warehouse/ Open Stockpile Inventory Control System

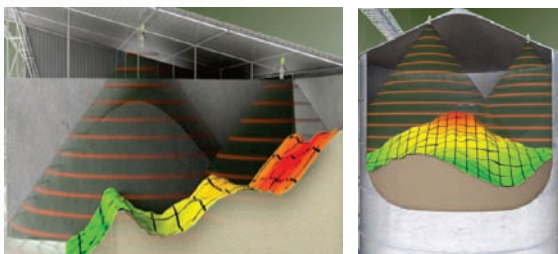

### Salient Features:

- Wide Beam Angle (70 to 80 degree) covers the whole silo/ bunker surface.
- Works even in heavy dust.
- Self Cleaning Ability.
- Provides True Level, Maximum Level, Minimum Level, Volume and Mass along with the Real Time 3D Profile of material inside the silo/ ESP.

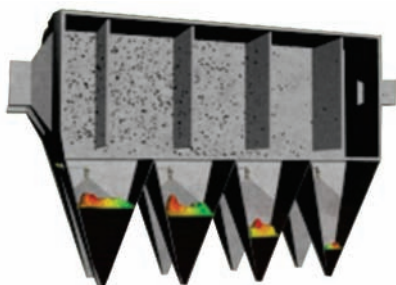

## 3D NON CONTACT RADAR LEVEL TRANSMITTER 140GHz

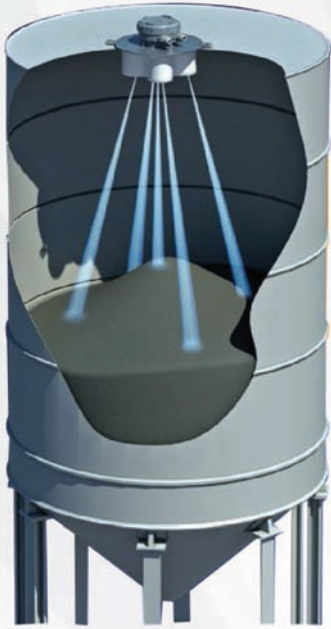

3D Radar Level Transmitter Model ULM 3D-5 (5 Beam Radar - The first and only 3D Radar Level Transmitter in the World). The RadarULM 3D-5 has an operating frequency of 140 GHz (World's Highest Operating Frequency) with 5 beams covering different parts of silo to provide you with Accurate Level, Volume, Mass and Real Time 3D Profile of material inside the Silo. Additionally, Radar Level Transmitter does not require any air purge for cleaning, as being a very high frequency and high power the Radar Beam is able to penetrate the dust and works even if some material sticks to the antenna of the 3D Radar.

### Applications :

- Silo/ Bunker Level and Inventory Solutions for all Bulk Solids and Powder Applications
- Flue gas Duct

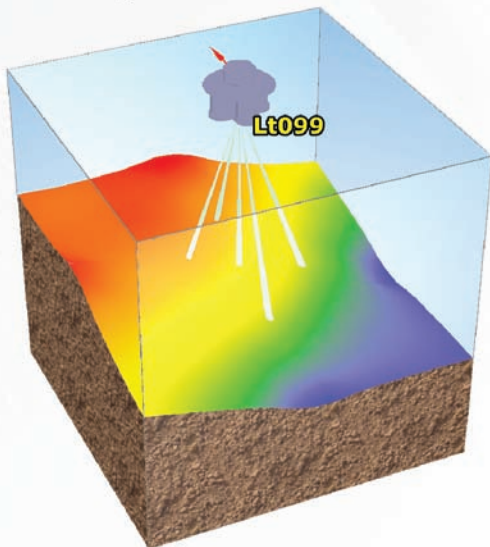
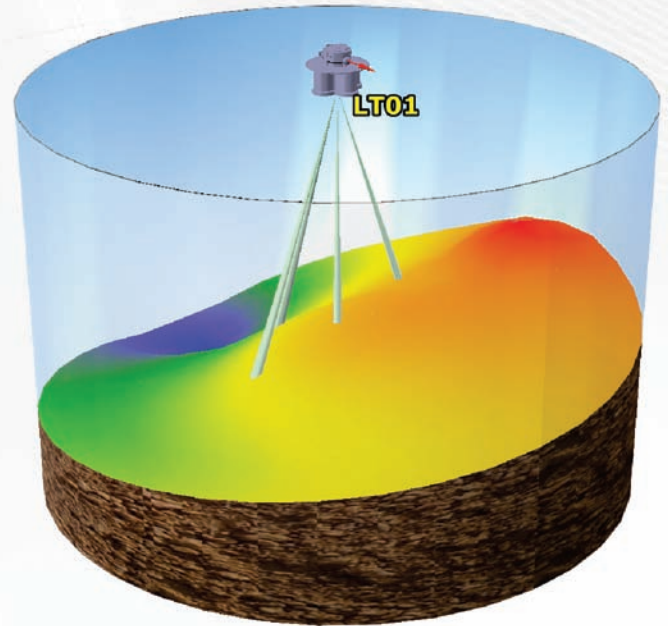

The 3D RADAR LEVEL TRANSMITTER with 5 beams

- Covers the Silo Surface Area at 5 different points to show the Level, Volume, and 3D Profile of material inside the Silo
- The 3D Radar Level Transmitter works well with the Dusty environment
- The 3D Radar Level Transmitter is maintenance free and does not require any air purge
- Provides true Level , Volume , Mass and Min/Max Level

### TIMELINE FOR LEVEL TRANSMITTER

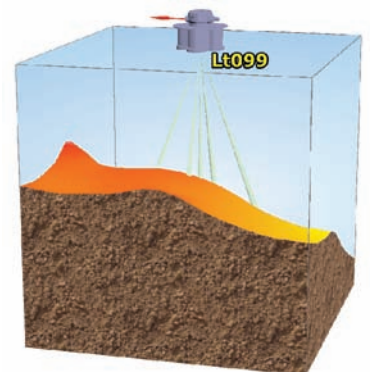
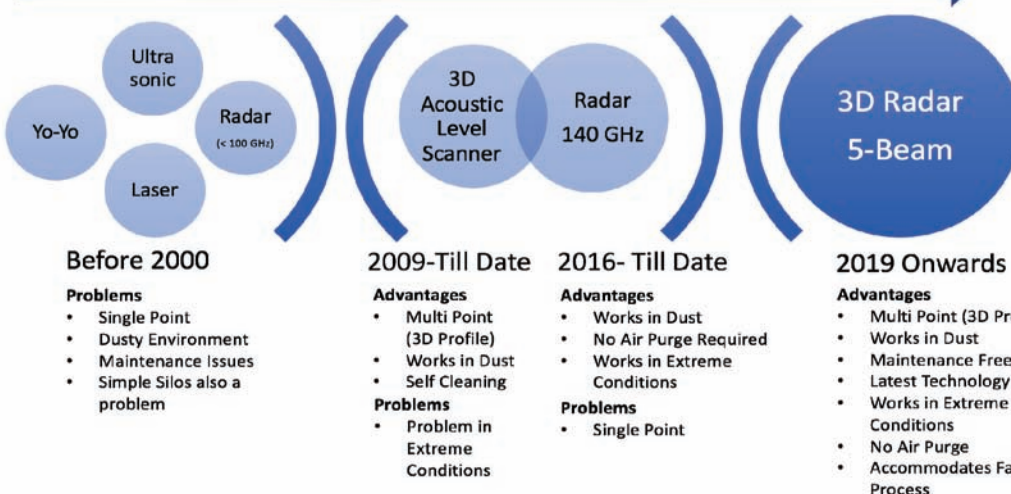

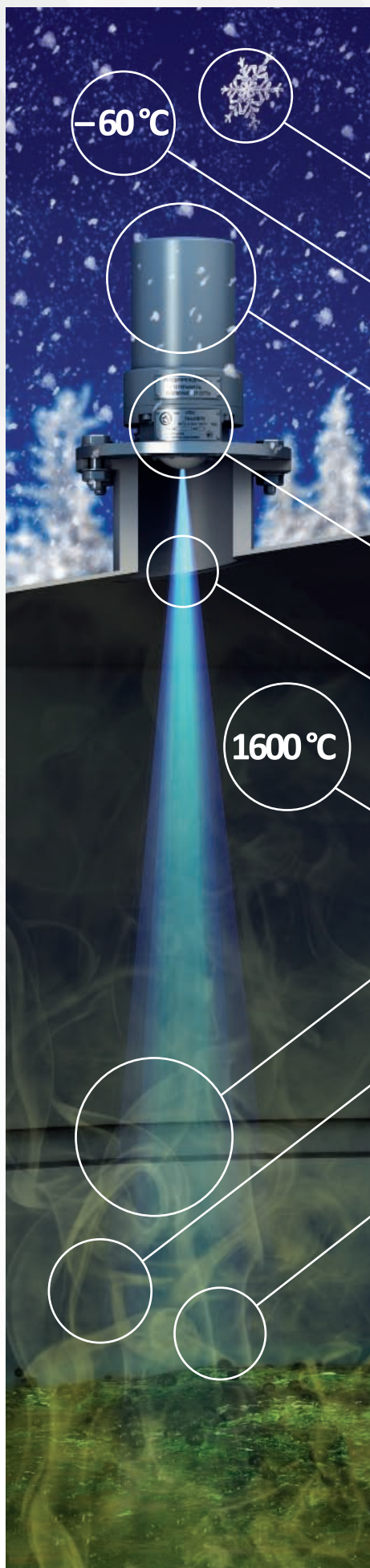

-60°C

1600°C

Free from atmospheric precipitation influence.

Environmental temperature from -60°C.

Mounted entirely outside the tank.

Antenna is located inside the level gauge housing, while being heated and protected by the fluoroplastic lens.

Narrow gauging beam - ease of installation, reliability of measurements.

Level gauging accuracy doesn't depend on the internal container temperature.

Measurements are influenced neither by evaporations nor by dust.

Level gauging of boiling liquid.

Level gauging of corrosive environments. No contact, no corrosion - reliable easurements.

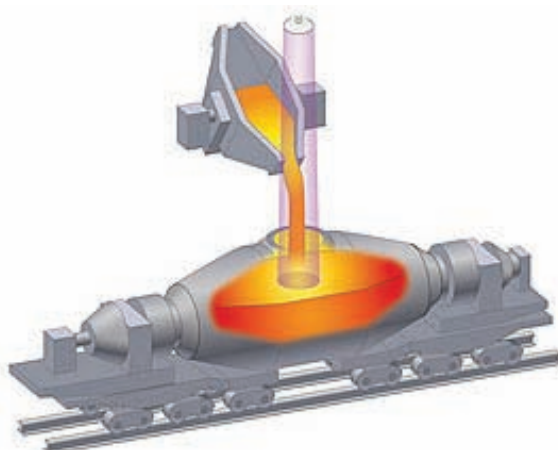
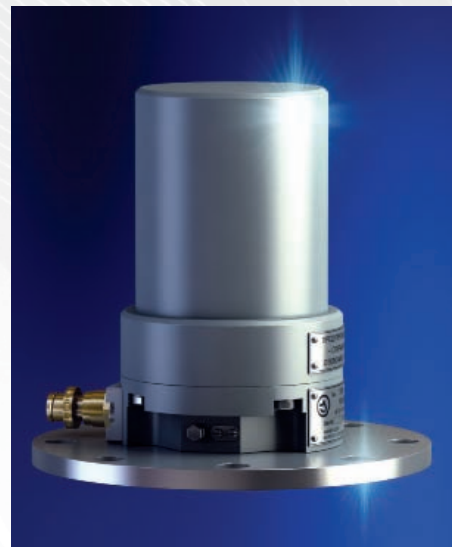

# OPEN / CLOSED STOCKPILE INVENTORY MANAGEMENT SYSTEM

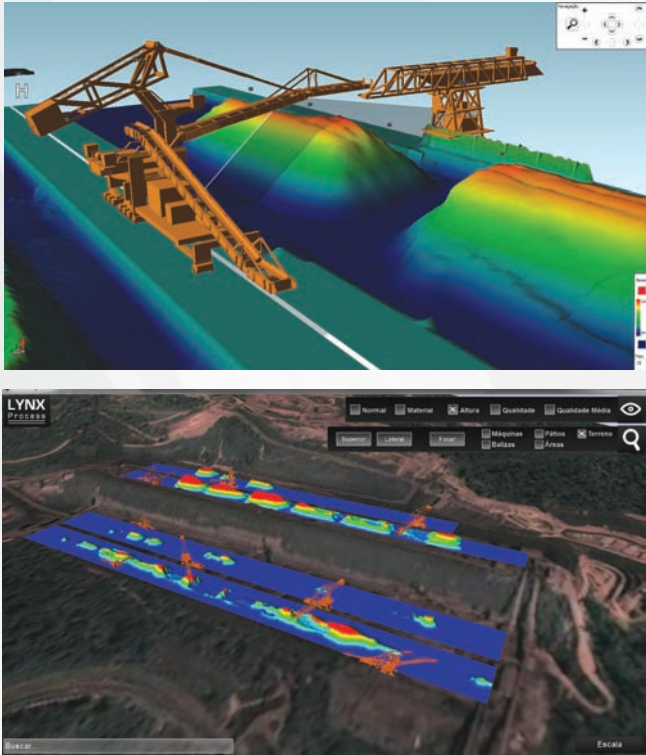

The 3D Laser scanner rotating on a 360 axis, scans the entire surrounding in a flash with multi point measurements on the surface per individual scanning cycle, offering exceptional accuracies when utilized to quantify hard and soft bulk commodities.

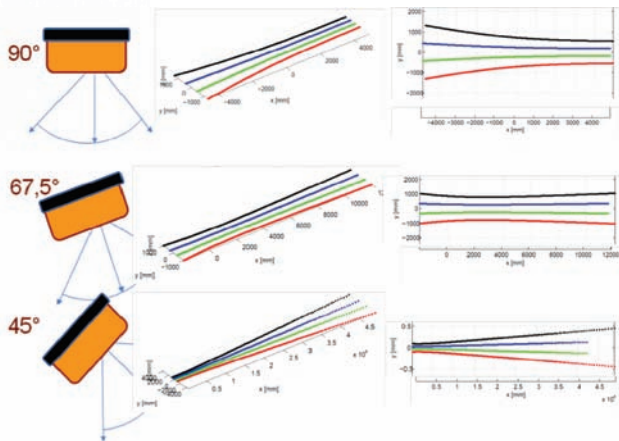
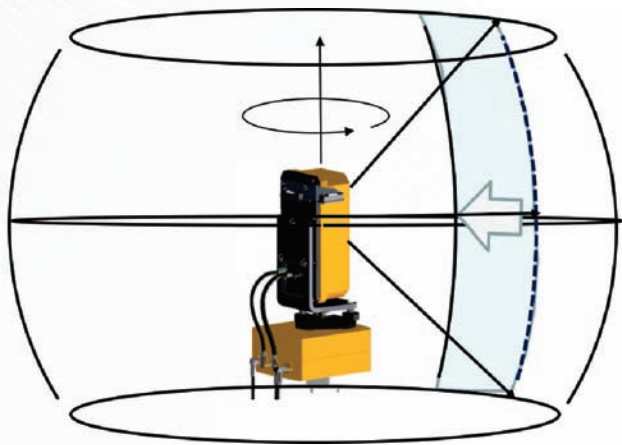

The 3D Stockpile measurement solution with 3D Laser Device mounted on the stacker machine or a moving tripper in the open field / closed warehouse and communicating through wireless to PC in control room running proprietary software provides Continuous Volume and 3D Profile of the Stockpile. The data along with 3D profile and history logs can be viewed on multiple PC's connected in LAN.



The 3D Laser Solution mounted on a stacker can function with a single scanner or multiple scanners in network, as required by the surface area of the commodity hence the stockpile area and the number of stockpiles is no limitation. The 3D Laser Scanner can also be mounted on the fixed structures individually or as multiple devices wherever a moving machine like stacker/reclaimer is unavailable.

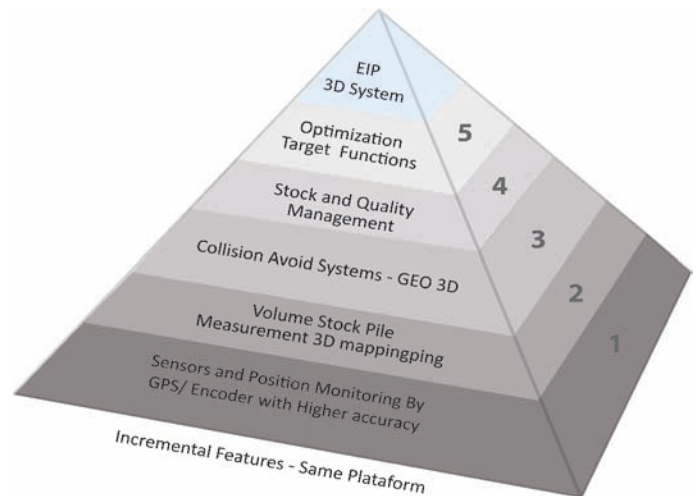
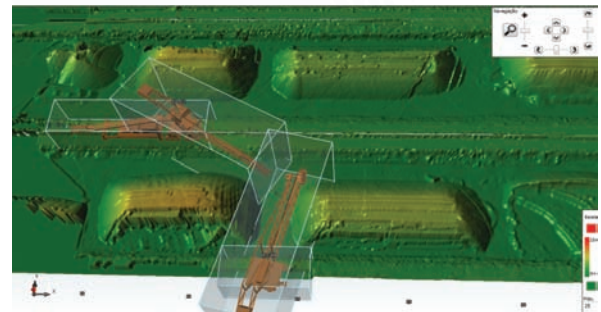

The 3D Laser Stockpile measurement system can be extended to a complete yard management system with features Anti Collision, Quality Monitoring System, Stock Optimization and Automated Man Less Yard Operation.

## NATURALLY OCCURRING GAMMA LEVEL SWITCH/TRANSMITTER

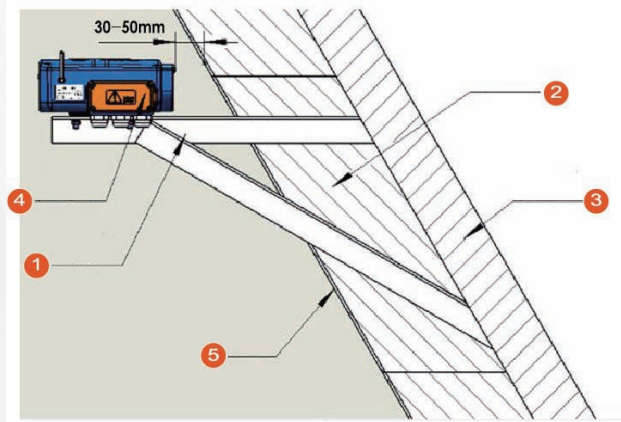

Installation diagram of CAS

- 1 Steel angle
- 2 Thermal insulation layer
- 3 Container wall
- 4 Coal ash sensor
- 5 Iron sheet

## NOGS Technology

NOGS (Naturally Occuring Gamma-ray Sensor), a new-type, secure  $\gamma$ -ray detection technology, widely applied in the level measurement of electrostatic precipitators of fly ash in the hopper.

$\gamma$ -ray detection technology of NOGS is free of dangerous, radioactive sources which are environmentally polluted, so this kind of technology is highly efficient and safe, which could easily help the coal-fired power plants to meet environmental regulation.

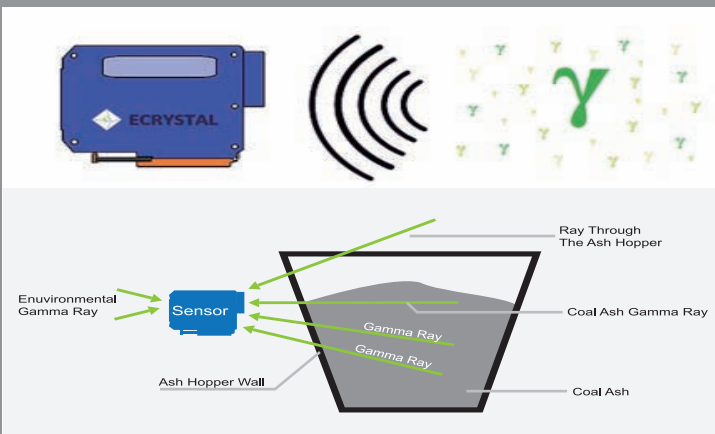

## ULTRASONIC DENSITY METER

The ENV200 is an ultrasonic instrument that measures the density of suspended solid in liquid. It comprises of sensors, a controller, and a junction box. ENV200 with PCM(Process Condition Monitoring) algorithm measures not only the size of received signal, which is often measured by conventional ultrasonic density meters but also observes changes in sound velocity and temperatures in the process. As it monitors operational status and water status in pipe and then decides the validity of each measurement, it contributes to increasing stability and reliability of the measurement. The ENV200 utilizes the EEA (Envelope Energy Average) method that saves reception signal envelop and then calculates its energy, rather than using the reception signal's amplitude change.



### Features

- Continuous and real-time measurement
- Reliable signal control EEAM(Envelope Energy Average Method) algorithm
- Various types of sensors to accommodate all field demands at installation
- Offer several density units, %, g/l, ppm, kg/m<sup>3</sup>, g/cm<sup>3</sup>
- Maximum 400 days data logging and monitoring
- In-situ measurement and calibration

### Applications

- Water / Wastewater Treatment
- Pulp and Paper
- Food and Beverage
- Power Plant
- Chemical
- Mining



## NON CONTACT NUCLEONIC DENSITY/LEVEL MEASUREMENT

“NTC Ecophyspribor” is a pioneer in the development of new environmentally friendly radio isotopic methods of control and measurement of process parameters and is engaged in the manufacture of process control devices for non contact process control and measurement (density meters, level gauges, continuous level gauges, thickness meters, concentration, media interface etc.).

Source: Na-22

Does not require any radiation license or approvals

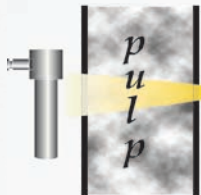
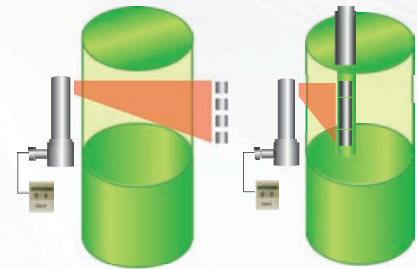

### Density measurement

of liquid media and slurries in pipelines, channels and reservoirs



### Continuous measurement

of level and boundary surface of liquid and loose media

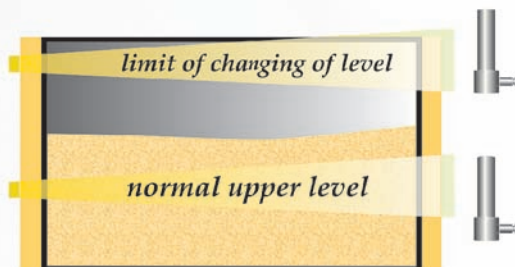

### Alarm indication

of level and boundary surface of liquid and loose media

## ADVANTAGES OF OUR DEVICES

- Completely noncontact
- Compact design
- No motion parts
- Maintenance free
- Indispensable when operating with various media such as:
  - Toxic, aggressive and biologically hazardous;
  - Corrosive and abrasive;
  - Molten and cryogenic;
  - Radioactive, with high or variable level of radioactivity
  - Foams, suspensions and slurry
  - Powders and other highly dispersed loose substances
  - Slurry, ore, fusion mixtures and alike
  - Without limitation of pressure and temperature inside a controlled object.

In contrast to its conventional radio isotopic analogues, our devices use natural and artificial gamma radiation sources which activities do not exceed the minimum significant activity levels pursuant to the applicable IAEA radiation safety standards and regulations. Therefore, they are not subject to the supervision by the State Nuclear Supervision Authority, State Sanitary Epidemiological Supervision Authority and Ministry of Home Affairs that are confirmed by appropriate documents.

Our devices:

- do not generate a radiation background;
- do not require a special radiation shield;
- do not pollute the environment;
- do not require specially prepared and certified premises and personnel
- do not create problems during dismantling of the equipment.

## NON CONTACT SOLID FLOW/ NO FLOW SWITCH



This system consists of a sensor probe mounted in a pneumatic pipeline, gravity chute or feeder and a control console mounted in an area accessible to users.

The Remote / Integral unit is a high quality, industrial grade instrument that senses flow / no-flow conditions using non intrusive Doppler technology (microwave) to provide highly reliable and sensitive motion detection. It works by transmitting a low energy signal through a Teflon process seal into the material flow stream. A portion of the signal is reflected back to the sensor, with the movement of material causing a frequency shift – called the Doppler shift - which is used by the sensor to detect material flow.

Both remote and integral versions are available and the typical application consists of Flow detection in Pneumatic Conveying Pipelines, Over Conveyor belts and other Solid Flow Pipelines

## NON CONTACT SOLID FLOW METERS

The solid flow meter DYNA M-flow is designed for flow measurement in metallic pipes from a few kg/h to many t/h. The system is suitable for on-line measurements of powders, dust, pellets, and granular from 1 nm up to 2 cm in pneumatic or free fall condition.

The measurement principle of the DYNA M-Flow is based upon the physical Doppler-Effect / Microwave Based, whereas the sensor generates a uniform field in the microwave frequency range inside the pipe. These microwaves are being reflected by particles passing through the pipe. Calculation of frequency and amplitude changes allows for accurate determination of solid flow. Nonmoving particles like dust accumulation are excluded from calculations.

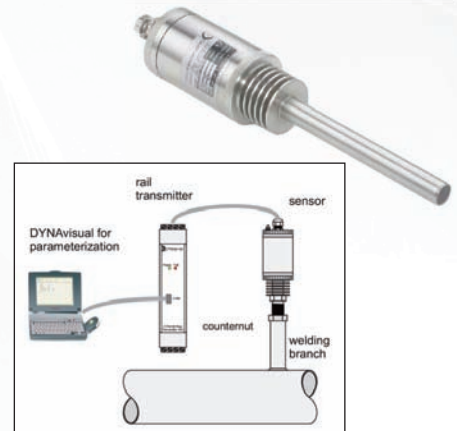

## LIQUID FLOW METERS

### NON CONTACT ULTRASONIC FLOW METER (Fixed and Portable type)

The Transit Time Flow Meter of TTFM series measures flow rate by calculating the spreading time of an ultrasonic wave in a liquid, going upstream and downstream into a pipe. This flow meter is mostly used to measure the flow rate of homogeneous fluids, also with a quite high percentage of suspended solids.

The measuring system is composed of a couple of ultrasonic transducers acoustically coupled to the external pipe's wall – clamp on sensors (it is also possible to use transducers in direct contact with fluid to be measured- called wetted sensors) and a HOST unit elaborating the signal that are sent and received from the transducers.



Clamp On

Insertion

Pipe

## KNIFE GATE VALVES



The WEY Knife Gate Valves stand for bi-directional zero-leakage shut-off, qualifies for all Liquids/ Slurry and Solid applications of various consistencies and have taken a leading international position due to their wide range of applications. Wey Knife Gate Valves have proven records in wastewater treatment plants, in pulp and paper, food and beverage, chemical and petrochemical industries, silo works and bulk material handling, mining and energy plants, in oil sand extraction and dust explosion prevention.

100% Safe process capability thanks to Bidirectional Zero-Leakage shut- off on pressure and vacuum which are Corrosion Resistant.

Failure-free operation due to Self Flushing and Full-bore Passage Designed for perfect flow pattern with optimized gate edge geometry

**APPLICATIONS :** Suitable for all Corrosive and Abrasive application including Metal slurry, Ash slurry and other Solids / Powers and liquid applications

### TECHNICAL SPECIFICATION

- Size : DN 50 – DN 1400, larger size on request
- Seal : NBR, EPDM, FPM, PUR, AFLAS, PTFE, Ceramic
- Flange drilling :EN 1092, ASME B16.5/B16.47 class 150/300
- Material : Cast iron EN-JL1040, Ductile iron EN-JS1030/1072, Cast steel, Stainless steel 1.4408, Duplex 1.4470, Titanium, Hastelloy, Aluminum, others
- Pressure rating / Vacuum : 10 bar, 16 bar, 25 bar, 40 bar, 100 bar / to 10 mbar absolute
- Temperature : -50 to 230°C at Max. Operating pressure  
240 to 400°C at atmospheric pressure
- Positioner : On/ Off Valve and Controlling Valve

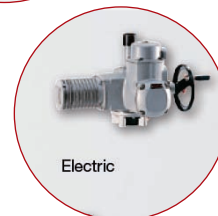
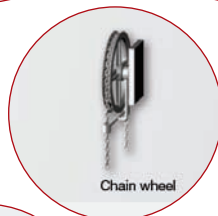

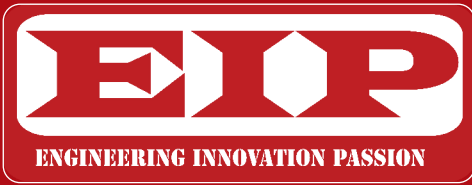

## About EIP

EIP was established about three decades ago, since then the company has been able to build its reputation in the field of Design / Manufacture Supply of accurate reliable POINT LEVEL AND INVENTORY CONTROL SYSTEMS which have proven to be in satisfactory operation under harsh environmental conditions. Apart from India EIP products have also been proven in other countries.

EIP aims to provide not only stable operating system but also to re-engineer equipments and systems as per the needs of the customers. This has been possible due to our wide experience in this field backed by constant technological development and absorption of new technologies developed world-wide.

EIP's strong endeavor to provide the best solution to its customers has gone a long way in introducing the most advanced level measurement technology from time to time.

Recent value addition to the Solutions provided by EIP is the Non Contact Ultrasonic Flow Meter which solves the problem of accurate flow measurement without any invasion into the pipeline, and the Solid Flow Detector which determines any choking or jamming of the pipelines in which ash or any other Solid material is flowing.

EIP has also diversified its portfolio to provide Zero leakage Non Corrosive Heavy Duty Knife Gate Valves, Butterfly Valves and Water Control Gate.

### **EIP ENVIRO LEVEL CONTROLS PVT. LTD.**

B-45, SECTOR-8, NOIDA-201301, (INDIA)

Tel. No. : 91-120-2421831,2421832 & 4243333

Fax No.: 91-120-2421833

Email: rgoyal@eipenviroindia.com, rajat@eipenviroindia.com

Website : www.eipenviroindia.com



URS is a member of Registrar of Standards (RSD) Ltd.