

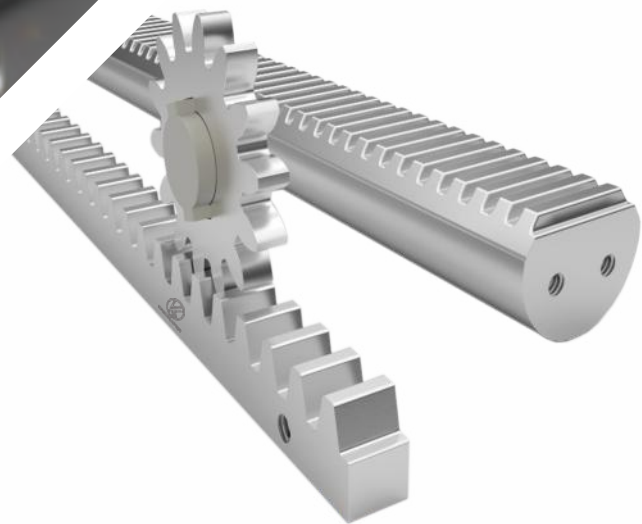

KREYMAYER

**RACKS
PINIONS
ROLLERS**

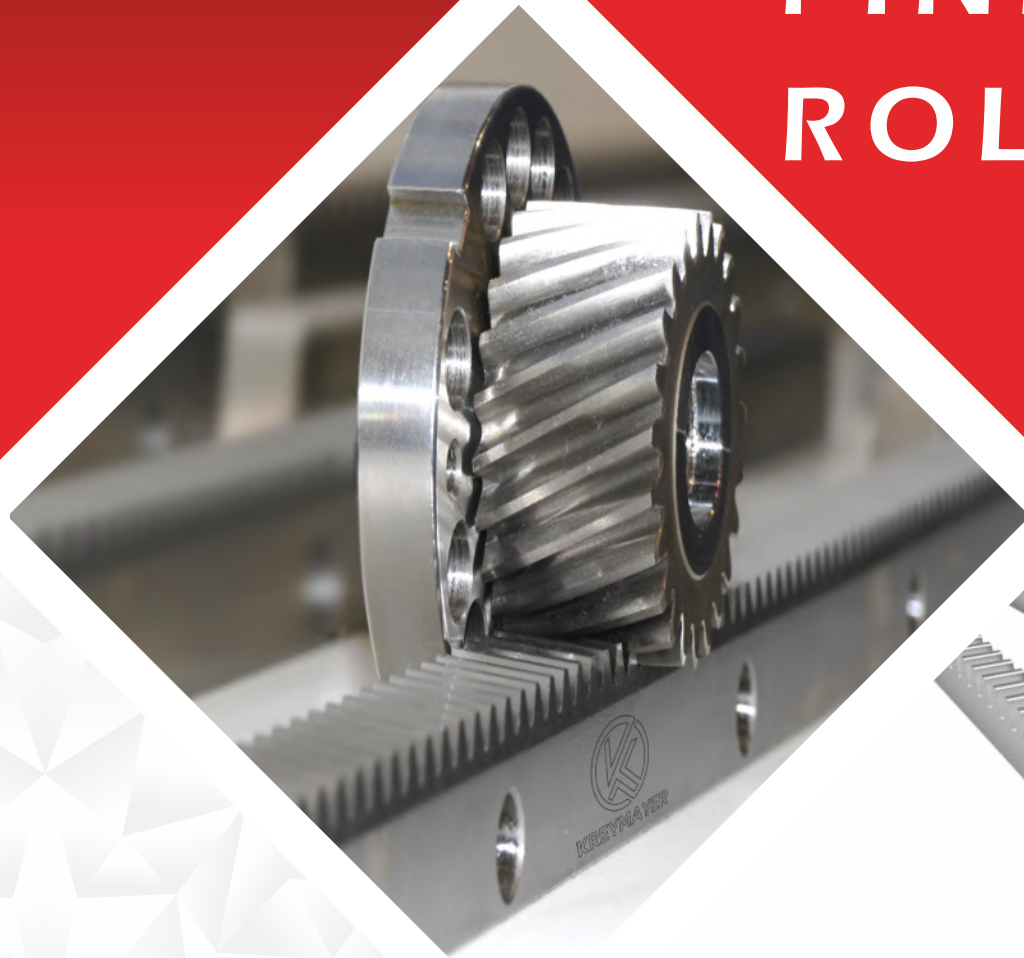

**POWER
PRECISION
PERFORMANCE**



INDEX



Specification & Quality Grade P.4
Contents of Racks P.5
Rack Code Instruction P.6
Racks P.7

Content of Guideway Racks P.18
Guideway Racks Code Instruction P.19
Guideway Racks P.20

Contents of Pinion P.29
Pinion Code Instruction P.30
Pinions P.31

Appendix

Definition P.75
Straight Gear Calculation P.76
Helical Gear Calculation P.77
Overload Factor K_a /Life Factor K_L /
Radial Contact Ratio of Standard Spur Gear P.78
Strength and Durability of Gears P.79
Steel Hardness Conversion Chart P.80
Conversion Table for Gear Pitch and Module P.81
Helical Rack Gauge for Assembling P.82
Straight Rack Gauge for Assembling P.83
Instruction of Rack Assembly Steps P.85



COMPANY PROFILE

In the field of drive technology, we have shown ourselves for over 36 years as a medium-sized family business that specialises in the creation of high-quality drive systems. Complex driving systems necessitate more stringent quality and performance standards for its components. New and innovative products from KREYMAYER have repeatedly adapted and executed these standards in recent years.

We are a well-known manufacturer of drive technology, and our goods include low-backlash gearboxes, racks and pinions manufactured at our factory in Navi Mumbai, India. Keeping up with the latest advancements in drive technology ensures that we are prepared for any issues that may arise. For servo gearheads, linear actuators, and racks, we provide unique solutions in addition to our inventory. Having a close working relationship with our clients is the foundation of our efficiency and success. In both domestic and foreign markets, our experts are respected for their sensible and competent advice. Whenever you have a technical problem, you can count on us for prompt and courteous assistance.

Strength axis drives requiring precise positioning and repeatability, travelling gantries and columns, pick-and-place robots, CNC routers, and material handling systems all benefit from the drives we manufacture. In addition, these drives are able to handle heavy loads and long duty cycles with ease. Material Handling, Automation, Automotive, Aerospace, Machine Tool, and Robotics are just a few of the fields we serve.

With linear force capacities of up to 92,000 pounds, the rack product line includes metric pitches from module 1.0 to 16.0. There are helical, straight (spur), integrated, and spherical racks, as well as other options. Customizable travel distances up to 3.00 metres are achievable by mounting end-to-end sections of the rack. Induction hardening, quenching, tempering, hardening and grinding (up to AGMA 12+ and DIN 4) are all options for quality.

For OEMs who want just-in-time delivery of these standard components, the typical delivery period is 2 to 3 weeks. Please consult the factory if you'd want to get custom or modified parts. Racks and pinions are available in stainless steel, as well as black oxide and chromium (Armoly®) coatings for use in harsh environments.





World Major Standard Specification of Racks and Pinions

Specification	Full Name
AGMA	American Gear Manufacturers Association
DIN	Deutsches Institut für Normung
ISO	International Organization for Standardization
JIS	Japanese Industrial Standards



Quality Grade Comparison Table

Standard	Quality Grade												
	1	2	3	4	5	6	7	8	9	10	11	12	
ISO													
DIN		2	3	4	5	6	7	8	9	10	11	12	
AGMA		15	14	13	12	11	10	9	8	7	6	5	
JIS				0	1	2	3	4	5	6	7	8	
JIS N				N4	N5	N6	N7	N8	N9	N10			

Fp fp Compared with Pitch Error: Fp fp



Contents of Racks

DIN

Code	DIN 3962	Material	Type	Teeth Treatment	Hardness	Mounted Holes	Module	Page
KCHRGH	DIN 5	S50C	Helical Right Hand 19°31'42"	Teeth Ground	Hardened HRC 50°-55°	Holes	1.5, 2, 2.5, 3, 4, 5, 6, 8	P.6
KCHRGH	DIN 6	S50C					1.5, 2, 2.5, 3, 4, 5, 6, 8, 10	P.7
KAHRG	DIN 6	SCM440					*	1.5, 2, 2.5, 3, 4, 5, 6, 8
KCHRM	DIN 8	S50C		Milled	* HRC18°-22° Quenched & Tempered		1.5, 2, 3, 4, 5, 6, 8, 10	P.9
KCHRMQ	DIN 8	S50C					1.5, 2, 3, 4, 5, 6, 8, 10	P.10
KCHRMH	DIN 10	S50C					Hardened HRC 50°-55°	1.5, 2, 3, 4, 5, 6, 8, 10
KCSRGH	DIN 5	S50C	Straight	Teeth Ground	Hardened HRC 50°-55°	2, 3, 4, 5	P.12	
KCSRGH	DIN 6	S50C				1.5, 2, 2.5, 3, 4, 5, 6, 8	P.13	
KCSRSM	DIN 8	S50C				*	1.5, 2, 3, 4, 5, 6, 8, 10	P.14
KCSRMQ	DIN 8	S50C		Milled	Quenched&Tempered HRC 18°-22°	1.5, 2, 3, 4, 5, 6, 8, 10	P.15	
KCSRMH	DIN 10	S50C				Hardened HRC 50°-55°	1.5, 2, 3, 4, 5, 6, 8, 10	P.16





Rack Code Instruction



1st	2nd	3rd	4th	5th	6th	7th	8th
Material	Type	Shape	Teeth Treatment	Hardness	Module	Length	Grade
C	S	R	G	H	020	10	DIN JIS
C= Carbon Steel =S50C A=Alloy Steel =SCM440	S=Straight H=Helical	R=Rhombus	M=Milled G=Ground	H=Hardened Q=Quenched & Tempered	M1.5~M10	05=500mm 10=1000mm 15=1500mm 20=2000mm	DIN 5-10 JIS 1-5

Remarks: Lengths, holes, materials, surface treatments (sandblasted, phosphated, Black-coated, sides ground) and other requirements all could be customized



KCSRM04010 - DC

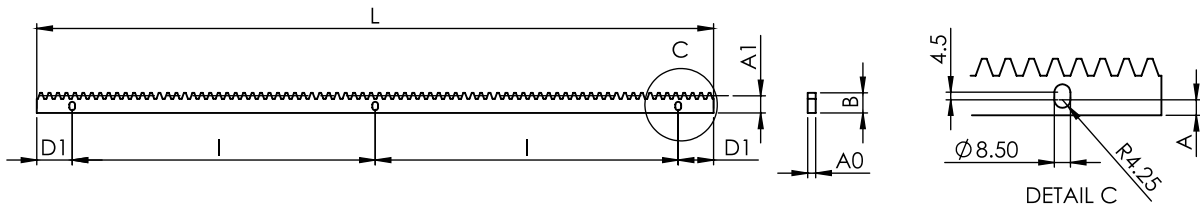

Material MS Bright
 Hardness: HRC 10~15°
 Surfaces Electroplated
 Total Pitch Error: $F_p/1000 \leq 0.036\text{mm}$
 DC Door Closure

Code	Module	L	No. of Teeth	B	A0	A1	D	I	No. of Holes	Scew	A	KG
KCSRM04010 - DC	4	1005	80	30	12	26	52.5	450	3	M8	8.25	2.35
KCSRM04010 - DC	4	1005	80	30	10	26	52.5	450	3	M8	8.25	2.35
KCSRM04010 - DC	4	1005	80	30	16	26	52.5	450	3	M8	8.25	2.35
KCSRM04010 - DC	4	1005	80	32	10	26	52.5	450	3	M8	8.25	2.35

KCSRM06010-DC

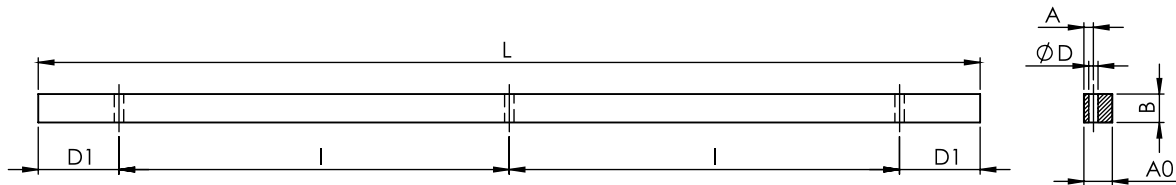

Code	Module	L	No. of Teeth	B	A0	A1	D1	D	I	No. of Holes	Scew	A	KG
KCSRM06010-DC	6	999	53	30	30	24	85.5	Ø10	414	3	M8	10	5.47



KCHRGH-DIN5

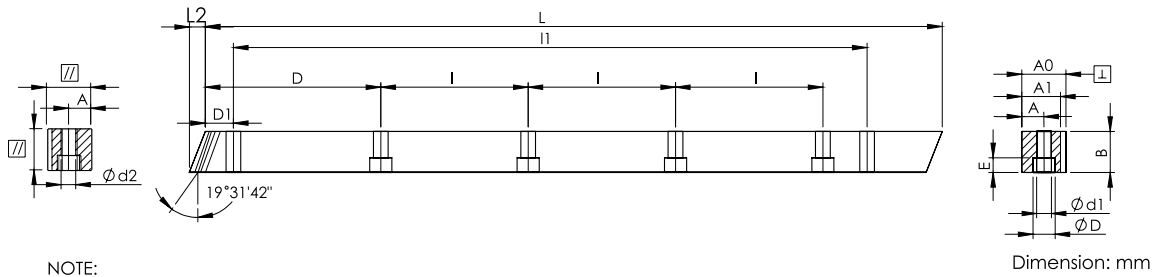

- NOTE:
 1) ALL THE SURFACES IN THE LEFT AND RIGHT VIEW ARE TRUE.
 2) ALL SURFACES HAVE Ra 0.8 SURFACE FINISH.
 3) ALL THE SURFACES ARE GROUND.

Series KCHRGH- DIN5 Helical Teeth Ground Racks
 Quality Grade DIN 5

Material S50C
 Right Hand Angle 19°31'42"
 Hardness: HRC 50~55°
 Ground on all sides after hardening.
 Total Pitch Error: $F_p / 1000 \leq 0.026$ mm
 Room Temperature is 25°C



Code	Module	L	L2	No. of Teeth	B	A0	A1	D	I	No. of Holes	A	ød1	øD	E	D1	I1	ød2	f	F _{ta} kN	KG
KCHRGH01505-DIN5	1.5	500.00	6.70	100	19	19	17.5	62.5	125	4	8	7	11	7	31.7	436.60	5.7	1.5	4.84	1.3
KCHRGH01510-DIN5	1.5	1000.00	6.70	200	19	19	17.5	62.5	125	8	8	7	11	7	31.7	936.60	5.7	1.5	4.84	2.6
KCHRGH02005-DIN5	2	500.00	8.50	75	24	24	22.0	62.5	125	4	8	7	11	7	31.7	436.60	5.7	2	8.15	2.1
KCHRGH02010-DIN5	2	1000.00	8.50	150	24	24	22.0	62.5	125	8	8	7	11	7	31.7	936.60	5.7	2	8.15	4.1
KCHRGH02505-DIN5	2.5	500.00	8.50	60	24	24	21.5	62.5	125	4	9	7	11	7	31.7	436.60	5.7	2	10.19	2.1
KCHRGH02510-DIN5	2.5	1000.00	8.50	120	24	24	21.5	62.5	125	8	9	7	11	7	31.7	936.60	5.7	2	10.19	4.1
KCHRGH03005-DIN5	3	500.00	10.30	50	29	29	26.0	62.5	125	4	9	10	15	9	35	430.00	7.7	2	14.77	3.0
KCHRGH03010-DIN5	3	1000.00	10.30	100	29	29	26.0	62.5	125	8	9	10	15	9	35	930.00	7.7	2	14.77	6.0
KCHRGH04005-DIN5	4	506.67	13.80	38	39	39	35.0	62.5	125	4	12	10	15	9	33.3	433.00	7.7	2	26.49	5.5
KCHRGH04010-DIN5	4	1000.00	13.80	75	39	39	35.0	62.5	125	8	12	10	15	9	33.3	933.40	7.7	2	26.49	10.8
KCHRGH05005-DIN5	5	500.00	17.40	30	49	49	34.0	62.5	125	4	12	14	20	13	37.5	425.00	11.7	3	41.60	6.8
KCHRGH05010-DIN5	5	1000.00	17.40	60	49	49	34.0	62.5	125	8	12	14	20	13	37.5	925.00	11.7	3	41.60	13.6
KCHRGH06005-DIN5	6	500.00	20.90	25	59	59	43.0	62.5	125	4	16	18	26	17	37.5	425.00	15.7	3	60.11	10.3
KCHRGH06010-DIN5	6	1000.00	20.90	50	59	59	43.0	62.5	125	8	16	18	26	17	37.5	925.00	15.7	3	60.11	20.5
KCHRGH08005-DIN5	8	480.00	28.00	18	79	79	71.0	60.0	120	4	25	22	33	21	120	240.00	19.7	4	107.31	21.3
KCHRGH08010-DIN5	8	960.00	28.00	36	79	79	71.0	60.0	120	8	25	22	33	21	120	720.00	19.7	4	107.31	42.6



KCHRGH-DIN6

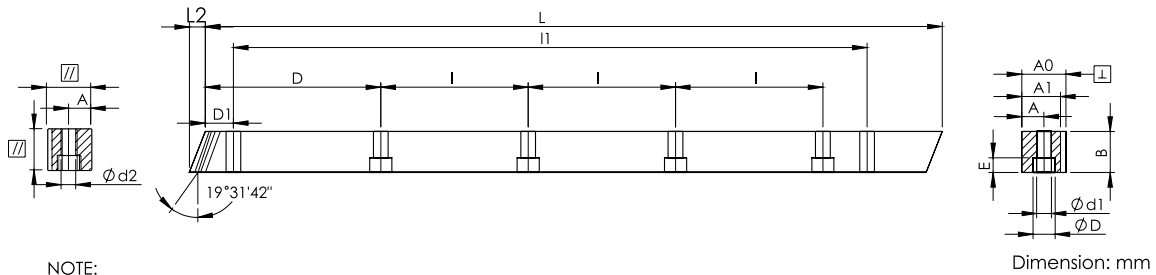

NOTE:
 1) ALL THE SURFACES IN THE LEFT AND RIGHT VIEW ARE TRUE.
 2) ALL SURFACES HAVE Ra 0.8 SURFACE FINISH.
 3) ALL THE SURFACES ARE GROUND.

Dimension: mm

Series KCHRGH-DIN6 Helical Teeth Ground Racks
 Quality Grade DIN 6

Material S50C
 Right Hand Angle 19°31'42"
 Hardness: HRC 50~55°
 Ground on all sides after hardening.
 Total Pitch Error: $F_p / 1000 \leq 0.036 \text{ mm}$
 $F_p / 2000 \leq 0.047 \text{ mm} (\leq 0.024/1000 \text{ mm})$

Code	Module	L	L2	No. of Teeth	B	A0	A1	D	I	No. of Holes	A	ød1	øD	E	D1	I1	ød2	f	F _{ta} kN	KG
KCHRGH01505-DIN6	1.5	500.00	6.70	100	19	19	17.5	62.5	125	4	8	7	11	7	31.7	436.60	5.7	1.5	4.84	1.3
KCHRGH01510-DIN6	1.5	1000.00	6.70	200	19	19	17.5	62.5	125	8	8	7	11	7	31.7	936.60	5.7	1.5	4.84	2.6
KCHRGH02005-DIN6	2	500.00	8.50	75	24	24	22.0	62.5	125	4	8	7	11	7	31.7	436.60	5.7	2	8.15	2.1
KCHRGH02010-DIN6	2	1000.00	8.50	150	24	24	22.0	62.5	125	8	8	7	11	7	31.7	936.60	5.7	2	8.15	4.1
KCHRGH02020-DIN6	2	2000.00	8.50	300	24	24	22.0	62.5	125	16	8	7	11	7	31.7	1936.60	5.7	2	8.15	8.2
KCHRGH02505-DIN6	2.5	500.00	8.50	60	24	24	21.5	62.5	125	4	9	7	11	7	31.7	436.60	5.7	2	10.19	2.1
KCHRGH02510-DIN6	2.5	1000.00	8.50	120	24	24	21.5	62.5	125	8	9	7	11	7	31.7	936.60	5.7	2	10.19	4.1
KCHRGH02520-DIN6	2.5	2000.00	8.50	240	24	24	21.5	62.5	125	16	9	7	11	7	31.7	1936.60	5.7	2	10.19	8.2
KCHRGH03005-DIN6	3	500.00	10.30	50	29	29	26.0	62.5	125	4	9	10	15	9	35.0	430.00	7.7	2	14.77	3.0
KCHRGH03010-DIN6	3	1000.00	10.30	100	29	29	26.0	62.5	125	8	9	10	15	9	35.0	930.00	7.7	2	14.77	6.0
KCHRGH03020-DIN6	3	2000.00	10.30	200	29	29	26.0	62.5	125	16	9	10	15	9	35.0	1930.00	7.7	2	14.77	12.0
KCHRGH04005-DIN6	4	506.67	13.80	38	39	39	35.0	62.5	125	4	12	10	15	9	33.3	433.00	7.7	2	26.49	5.5
KCHRGH04010-DIN6	4	1000.00	13.80	75	39	39	35.0	62.5	125	8	12	10	15	9	33.3	933.40	7.7	2	26.49	10.8
KCHRGH04020-DIN6	4	2000.00	13.80	150	39	39	35.0	62.5	125	16	12	10	15	9	33.3	1933.40	7.7	2	26.49	21.6
KCHRGH05005-DIN6	5	500.00	17.40	30	49	39	34.0	62.5	125	4	12	14	20	13	37.5	425.00	11.7	3	41.60	6.8
KCHRGH05010-DIN6	5	1000.00	17.40	60	49	39	34.0	62.5	125	8	12	14	20	13	37.5	925.00	11.7	3	41.60	13.6
KCHRGH05020-DIN6	5	2000.00	17.40	120	49	39	34.0	62.5	125	16	12	14	20	13	37.5	1925.00	11.7	3	41.60	27.2
KCHRGH06005-DIN6	6	500.00	20.90	25	59	49	43.0	62.5	125	4	16	18	26	17	37.5	425.00	15.7	3	60.11	10.3
KCHRGH06010-DIN6	6	1000.00	20.90	50	59	49	43.0	62.5	125	8	16	18	26	17	37.5	925.00	15.7	3	60.11	20.5
KCHRGH06020-DIN6	6	2000.00	20.90	100	59	49	43.0	62.5	125	16	16	18	26	17	37.5	1925.00	15.7	3	60.11	41.1
KCHRGH08005-DIN6	8	480.00	28.00	18	79	79	71.0	60.0	120	4	25	22	33	21	120.0	240.00	19.7	4	107.31	21.3
KCHRGH08010-DIN6	8	960.00	28.00	36	79	79	71.0	60.0	120	8	25	22	33	21	120.0	720.00	19.7	4	107.31	42.6
KCHRGH08020-DIN6	8	1920.00	28.00	72	79	79	71.0	60.0	120	16	25	22	33	21	120.0	1680.00	19.7	4	107.31	85.1
KCHRGH10005-DIN6	10	500.00	35.11	15	99	99	89.0	62.5	125	4	32	33	48	32	125.0	250.00	19.7	5	168.10	34.8
KCHRGH10010-DIN6	10	1000.00	35.11	30	99	99	89.0	62.5	125	8	32	33	48	32	125.0	750.00	19.7	5	168.10	69.6



KAHRG-DIN6

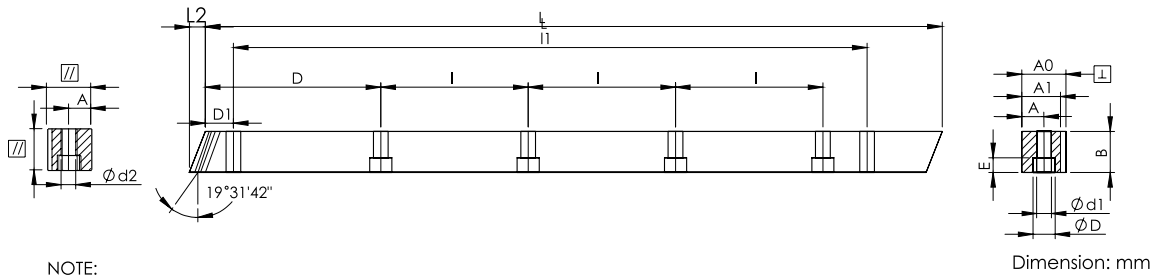

- NOTE:
- 1) ALL THE SURFACES IN THE LEFT AND RIGHT VIEW ARE TRUE.
 - 2) ALL SURFACES HAVE Ra 0.8 SURFACE FINISH.
 - 3) ALL THE SURFACES ARE GROUND.

Series KAHRG-DIN6 Helical Teeth Ground Racks
Quality Grade DIN 6

Material SCM440
Right Hand Angle 19°31'42"
Hardness: HRC 50~55°
Ground on all sides.
Total Pitch Error: $F_p / 1000 \leq 0.036 \text{ mm}$
 $F_p / 2000 \leq 0.047 \text{ mm (} \leq 0.024 / 1000 \text{ mm)}$

Code	Module	L	L2	No. of Teeth	B	A0	A1	D	I	No. of Holes	A	ød1	øD	E	D1	I1	ød2	f	F _{ta} kN	KG
KAHRG01505-DIN6	1.5	500.00	6.70	100	19	19	17.5	62.5	125	4	8	7	11	7	31.7	436.60	5.7	1.5	0.94	1.3
KAHRG01510-DIN6	1.5	1000.00	6.70	200	19	19	17.5	62.5	125	8	8	7	11	7	31.7	936.60	5.7	1.5	0.94	2.6
KAHRG02005-DIN6	2	500.00	8.50	75	24	24	22.0	62.5	125	4	8	7	11	7	31.7	436.60	5.7	2	1.58	2.1
KAHRG02010-DIN6	2	1000.00	8.50	150	24	24	22.0	62.5	125	8	8	7	11	7	31.7	936.60	5.7	2	1.58	4.1
KAHRG02020-DIN6	2	2000.00	8.50	300	24	24	22.0	62.5	125	16	8	7	11	7	31.7	1936.60	5.7	2	1.58	8.2
KAHRG02505-DIN6	2.5	500.00	8.50	60	24	24	21.5	62.5	125	4	9	7	11	7	31.7	436.60	5.7	2	1.98	2.1
KAHRG02510-DIN6	2.5	1000.00	8.50	120	24	24	21.5	62.5	125	8	9	7	11	7	31.7	936.60	5.7	2	1.98	4.1
KAHRG02520-DIN6	2.5	2000.00	8.50	240	24	24	21.5	62.5	125	16	9	7	11	7	31.7	1936.60	5.7	2	1.98	8.2
KAHRG03005-DIN6	3	500.00	10.30	50	29	29	26.0	62.5	125	4	9	10	15	9	35.0	430.00	7.7	2	2.87	3.0
KAHRG03010-DIN6	3	1000.00	10.30	100	29	29	26.0	62.5	125	8	9	10	15	9	35.0	930.00	7.7	2	2.87	6.0
KAHRG03020-DIN6	3	2000.00	10.30	200	29	29	26.0	62.5	125	16	9	10	15	9	35.0	1930.00	7.7	2	2.87	12.0
KAHRG04005-DIN6	4	506.67	13.80	38	39	39	35.0	62.5	125	4	12	10	15	9	33.3	433.00	7.7	2	5.15	5.5
KAHRG04010-DIN6	4	1000.00	13.80	75	39	39	35.0	62.5	125	8	12	10	15	9	33.3	933.40	7.7	2	5.15	10.8
KAHRG04020-DIN6	4	2000.00	13.80	150	39	39	35.0	62.5	125	16	12	10	15	9	33.3	1933.40	7.7	2	5.15	21.6
KAHRG05005-DIN6	5	500.00	17.40	30	49	39	34.0	62.5	125	4	12	14	20	13	37.5	425.00	11.7	3	8.08	6.8
KAHRG05010-DIN6	5	1000.00	17.40	60	49	39	34.0	62.5	125	8	12	14	20	13	37.5	925.00	11.7	3	8.08	13.6
KAHRG05020-DIN6	5	2000.00	17.40	120	49	39	34.0	62.5	125	16	12	14	20	13	37.5	1925.00	11.7	3	8.08	27.2
KAHRG06005-DIN6	6	500.00	20.90	25	59	49	43.0	62.5	125	4	16	18	26	17	37.5	425.00	15.7	3	11.68	10.3
KAHRG06010-DIN6	6	1000.00	20.90	50	59	49	43.0	62.5	125	8	16	18	26	17	37.5	925.00	15.7	3	11.68	20.5
KAHRG06020-DIN6	6	2000.00	20.90	100	59	49	43.0	62.5	125	16	16	18	26	17	37.5	1925.00	15.7	3	11.68	41.1
KAHRG08005-DIN6	8	480.00	28.00	18	79	79	71.0	60.0	120	4	25	22	33	21	120.0	240.00	19.7	4	20.85	21.3
KAHRG08010-DIN6	8	960.00	28.00	36	79	79	71.0	60.0	120	8	25	22	33	21	120.0	720.00	19.7	4	20.85	42.6
KAHRG08020-DIN6	8	1920.00	28.00	72	79	79	71.0	60.0	120	16	25	22	33	21	120.0	1680.00	19.7	4	20.85	85.1



KCHRM-DIN8

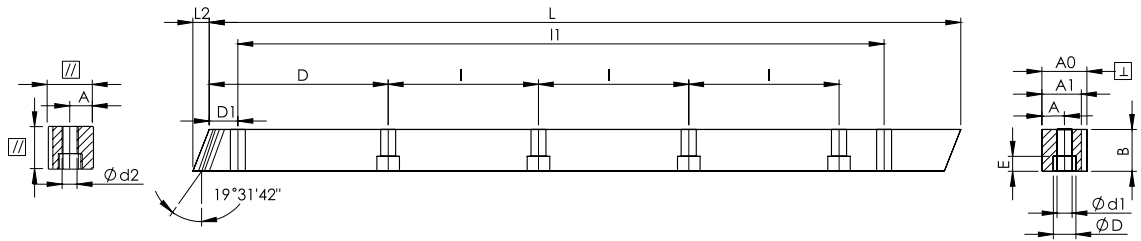

- NOTE:
- 1) ALL THE SURFACES IN THE LEFT AND RIGHT VIEW ARE TRUE.
 - 2) ALL SURFACES HAVE Ra 1.6 SURFACE FINISH.
 - 3) ALL THE SURFACES ARE MILLED.

Dimension: mm

Helical

DIN

Series KCHRM-DIN8 Helical Milled Racks
Quality Grade DIN 8

Material S50C
Right Hand Angle 19°31'42"
Hardness: HRC 50~55°
Total Pitch Error: $F_p / 1000 \leq 0.060$ mm
 $F_p / 2000 \leq 0.080$ mm

Code	Module	L	L2	No. of Teeth	B	A0	A1	D	I	No. of Holes	A	ød1	øD	E	D1	I1	ød2	f	F _{ta} kN	KG
KCHRM01510-DIN8	1.5	1000	6.00	200	17	17	15.5	62.5	125	8	7	6	9.5	6	31.7	936.6	5.70	1.5	0.64	2.1
KCHRM02010-DIN8	2	1000	8.90	150	25	24	22	62.5	125	8	8	7	11	7	31.7	936.6	5.70	2	1.25	4.3
KCHRM03010-DIN8	3	1000	10.60	100	30	29	26	62.5	125	8	9	10	15	9	35.0	930.0	7.70	2	2.24	6.2
KCHRM04010-DIN8	4	1000	14.20	75	40	39	35	62.5	125	8	12	10	15	9	33.3	933.4	7.70	2	3.99	11.1
KCHRM05010-DIN8	5	1000	17.40	60	49	39	34	62.5	125	8	12	14	20	13	37.5	925.0	11.70	3	6.11	13.6
KCHRM06010-DIN8	6	1000	20.90	50	59	49	43	62.5	125	8	16	18	26	17	37.5	925.0	15.70	3	8.83	20.5
KCHRM08010-DIN8	8	960	28.00	36	79	79	71	60	120	8	25	22	33	21	120.0	720.0	19.70	4	15.76	42.6
KCHRM08020-DIN8	8	1920	28.00	72	79	79	71	60	120	16	25	22	33	21	120.0	1680.0	19.70	4	15.76	85.1
KCHRM10010-DIN8	10	1000	35.11	30	99	99	89	62.5	125	8	32	33	48	32	125.0	750.0	19.70	5	24.69	69.6



KCHRMQ-DIN8

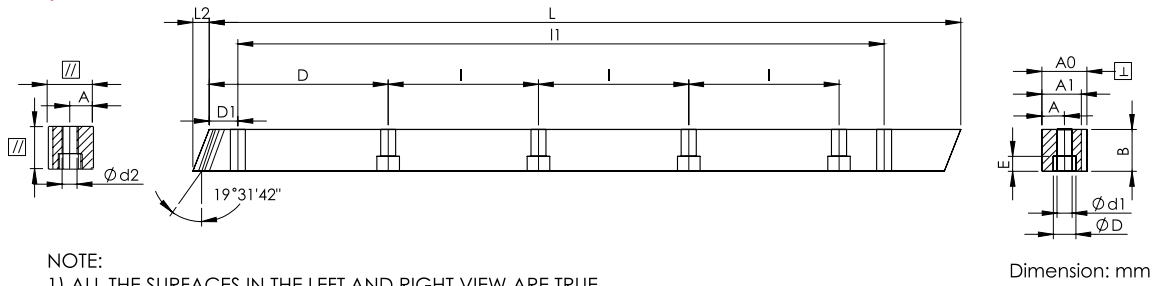

- NOTE:
- 1) ALL THE SURFACES IN THE LEFT AND RIGHT VIEW ARE TRUE.
 - 2) ALL SURFACES HAVE Ra 1.6 SURFACE FINISH.
 - 3) ALL THE SURFACES ARE MILLED.

Series KCHRMQ-DIN8 Helical Milled Quenched and Tempered Racks
Quality Grade DIN 8

Material S50C
Right Hand Angle 19°31'42"
Hardness: HRC 50~55°
Total Pitch Error: $F_p / 1000 \leq 0.060$ mm
 $F_p / 2000 \leq 0.080$ mm



Code	Module	L	L2	No. of Teeth	B	A0	A1	D	I	No. of Holes	A	ød1	øD	E	D1	I1	ød2	f	F _{ta} kN	KG
KCHRMQ01510-DIN8	1.5	1000	6.00	200	17	17	15.5	62.5	125	8	7	6	9.5	7	31.7	936.6	5.7	1.5	0.88	2.1
KCHRMQ02010-DIN8	2	1000	8.90	150	25	24	22	62.5	125	8	8	7	11	7	31.7	936.6	5.7	2	1.73	4.3
KCHRMQ03010-DIN8	3	1000	10.60	100	30	29	26	62.5	125	8	9	10	15	9	35.0	930.0	7.7	2	3.11	6.2
KCHRMQ04010-DIN8	4	1000	14.20	75	40	39	35	62.5	125	8	12	10	15	9	33.3	933.4	7.7	2	5.52	11.1
KCHRMQ05010-DIN8	5	1000	17.40	60	49	39	34	62.5	125	8	12	14	20	13	37.5	925.0	11.7	3	8.46	13.6
KCHRMQ06010-DIN8	6	1000	20.90	50	59	49	43	62.5	125	8	16	18	26	17	37.5	925.0	15.7	3	12.22	20.5
KCHRMQ08010-DIN8	8	960	28.00	36	79	79	71	60	120	8	25	22	33	21	120.0	720.0	19.7	4	21.81	42.6
KCHRMQ08020-DIN8	8	1920	28.00	18	79	79	71	60	120	16	25	22	33	21	120.0	1680.0	19.7	4	21.81	85.1
KCHRMQ10010-DIN8	10	1000	35.11	30	99	99	89	62.5	125	8	32	33	48	32	125.0	750.0	19.7	5	34.17	69.6



KCHRMH-DIN10

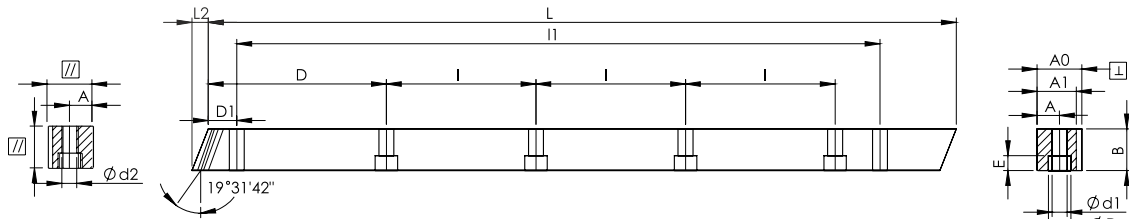

- NOTE:
- 1) ALL THE SURFACES IN THE LEFT AND RIGHT VIEW ARE TRUE.
 - 2) ALL SURFACES HAVE Ra 2.4 SURFACE FINISH.
 - 3) ALL THE SURFACES ARE GROUND.

Dimension: mm

Series KCHRMH-DIN 10 Helical Hardened Racks
Quality Grade DIN 10

Material S50C
Right Hand Angle 19°31'42"
Hardness: HRC 50~55°
Surfaces: Sand-blasted.
Total Pitch Error: $F_p / 1000 \leq 0.15$ mm

Code	Module	L	L2	No. of Teeth	B	A0	A1	D	I	No. of Holes	A	ød1	øD	E	D1	I1	ød2	f	F _{ta} kN	KG
KCHRMH01510-DIN10	1.5	1000	6.00	200	17	17	15.5	62.5	125	8	7	6	9.5	7	31.7	936.6	5.7	3.18	2.1	
KCHRMH02010-DIN10	2	1000	8.50	150	24	24	22	62.5	125	8	8	7	11	7	31.7	936.6	5.7	5.98	4.1	
KCHRMH02020-DIN10	2	2000	8.50	300	24	24	22	62.5	125	16	8	7	11	7	31.7	1936.6	5.7	5.98	8.2	
KCHRMH03010-DIN10	3	1000	10.30	100	29	29	26	62.5	125	8	9	10	15	9	35.0	930.0	7.7	10.83	6.0	
KCHRMH03020-DIN10	3	2000	10.30	200	29	29	26	62.5	125	16	9	10	15	9	35.0	1930.0	7.7	10.83	12.0	
KCHRMH04010-DIN10	4	1000	13.80	75	39	39	35	62.5	125	8	12	10	15	9	33.3	933.4	7.7	19.42	10.8	
KCHRMH04020-DIN10	4	2000	13.80	150	39	39	35	62.5	125	16	12	10	15	9	33.3	1933.4	7.7	19.42	21.6	
KCHRMH05010-DIN10	5	1000	17.40	60	49	49	34	62.5	125	8	12	14	20	13	37.5	925.0	11.7	30.51	13.6	
KCHRMH05020-DIN10	5	2000	17.40	120	49	49	34	62.5	125	16	12	14	20	13	37.5	1925.0	11.7	30.51	27.2	
KCHRMH06010-DIN10	6	1000	20.90	50	59	59	43	62.5	125	8	16	18	26	17	37.5	925.0	15.7	44.08	20.5	
KCHRMH06020-DIN10	6	2000	20.90	100	59	59	43	62.5	125	16	16	18	26	17	37.5	1925.0	15.7	44.08	41.1	
KCHRMH08010-DIN10	8	960	28.00	36	79	79	71	60	120	8	25	22	33	21	120.0	720.0	19.7	78.69	42.6	
KCHRMH08020-DIN10	8	1920	28.00	72	79	79	71	60	120	16	25	22	33	21	120.0	1680.0	19.7	78.69	85.1	
KCHRMH10010-DIN10	10	1000	35.11	30	99	99	89	62.5	125	8	32	33	48	32	125.0	750.0	19.7	123.27	69.6	



KCSRGH-DIN5

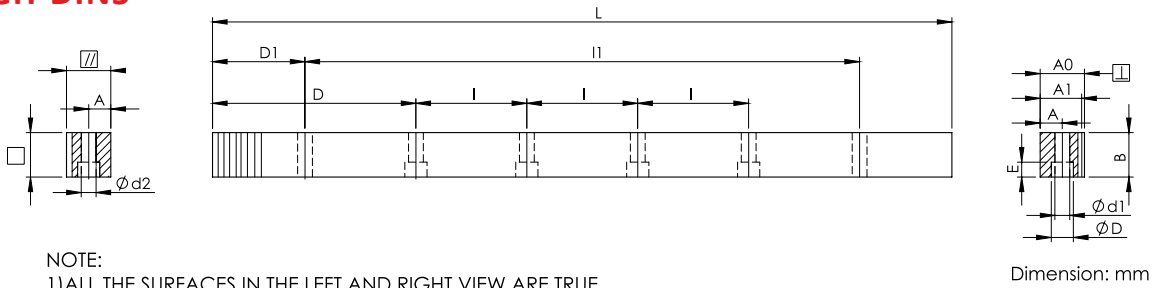

- NOTE:
- 1) ALL THE SURFACES IN THE LEFT AND RIGHT VIEW ARE TRUE.
 - 2) ALL THE SURFACES HAVE Ra 0.8 SURFACE FINISH.
 - 3) ALL THE SURFACES ARE GROUND.

Series KCSRGH-DIN5 Straight Teeth Ground Racks
Quality Grade DIN 5

Material S50C
Hardness: HRC 50~55°
Ground on all sides after hardening.
Total Pitch Error: $F_p / 1000 \leq 0.026$ mm
Room Temperature is 25°C



Code	Module	L	No. of Teeth	B	A0	A1	D	I	No. of Holes	A	ød1	øD	E	D1	I1	ød2	f	F _{ta} kN	KG
KCSRGH02010-DIN5	2	1005.31	160	24	24	22	62.83	125.66	8	8	7	11	7	31.3	942.70	5.7	2	5.69	4.1
KCSRGH03010-DIN5	3	1017.88	108	29	29	26	63.61	127.23	8	9	10	11	9	34.4	949.10	7.7	2	10.32	6.1
KCSRGH04010-DIN5	4	1005.31	80	39	39	35	62.83	125.66	8	12	10	15	9	37.5	930.30	7.7	2	18.50	10.9
KCSRGH05010-DIN5	5	1005.31	64	49	39	34	62.83	125.66	8	12	14	17	13	37.5	945.00	11.7	3	29.06	17.2



KCSRGH-DIN6

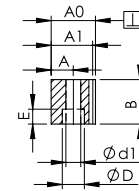
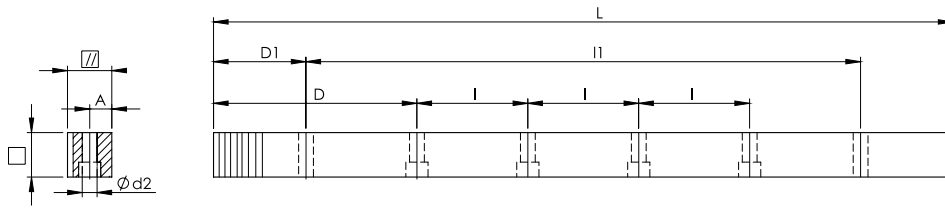

Dimension: mm

- NOTE:
 1) ALL THE SURFACES IN THE LEFT AND RIGHT VIEW ARE TRUE.
 2) ALL THE SURFACES HAVE Ra 0.8 SURFACE FINISH.
 3) ALL THE SURFACES ARE GROUND.

Straight
DIN

Series KCSRGH-DIN6 Straight Teeth Ground Racks
 Quality Grade DIN 6

Material S50C
 Hardness: HRC 50~55°
 Ground on all sides after hardening.
 Total Pitch Error: $F_p / 1000 \leq 0.036 \text{ mm}$
 $F_p / 2000 \leq 0.047 \text{ mm} (\leq 0.024/1000 \text{ mm})$

Code	Module	L	No. of Teeth	B	A0	A1	D	I	No. of Holes	A	ød1	øD	E	D1	I1	ød2	f	F _{ta} kN	KG
KCSRGH01505-DIN6	1.5	499.51	106	19	19	17.5	62.44	124.88	4	8	6	9.5	7	29.0	441.50	5.7	1.5	3.38	1.3
KCSRGH01510-DIN6	1.5	999.03	212	19	19	17.5	62.44	124.88	8	8	6	9.5	7	29.0	941.00	5.7	1.5	3.38	2.6
KCSRGH02005-DIN6	2	502.65	80	24	24	22	62.83	125.66	4	8	7	11	7	31.3	440.10	5.7	2	5.69	2.1
KCSRGH02010-DIN6	2	1005.31	160	24	24	22	62.83	125.66	8	8	7	11	7	31.3	942.70	5.7	2	5.69	4.1
KCSRGH02020-DIN6	2	2010.62	320	24	24	22	62.83	125.66	16	8	7	11	7	31.3	1948.00	5.7	2	5.69	8.2
KCSRGH02505-DIN6	2.5	502.65	64	24	24	21.5	62.83	125.66	4	9	7	11	7	31.3	440.10	5.7	2	7.12	2.1
KCSRGH02510-DIN6	2.5	1005.31	128	24	24	21.5	62.83	125.66	8	9	7	11	7	31.3	942.70	5.7	2	7.12	4.1
KCSRGH02520-DIN6	2.5	2010.62	256	24	24	21.5	62.83	125.66	16	9	7	11	7	31.3	1948.00	5.7	2	7.12	8.2
KCSRGH03005-DIN6	3	508.94	54	29	29	26	63.62	127.23	4	9	10	15	9	34.4	440.10	7.7	2	10.32	3.0
KCSRGH03010-DIN6	3	1017.88	108	29	29	26	63.62	127.23	8	9	10	15	9	34.4	949.10	7.7	2	10.32	6.1
KCSRGH03020-DIN6	3	2035.75	216	29	29	26	63.62	127.23	16	9	10	15	9	34.4	1967.00	7.7	2	10.32	12.2
KCSRGH04005-DIN6	4	502.65	40	39	39	35	62.83	125.66	4	12	10	15	9	37.5	427.70	7.7	2	18.50	5.4
KCSRGH04010-DIN6	4	1005.31	80	39	39	35	62.83	125.66	8	12	10	15	9	37.5	930.30	7.7	2	18.50	10.9
KCSRGH04020-DIN6	4	2010.62	160	39	39	35	62.83	125.66	16	12	10	15	9	37.5	1935.60	7.7	2	18.50	21.7
KCSRGH05005-DIN6	5	502.65	32	49	49	39	62.83	125.66	4	12	14	20	13	30.1	442.30	11.7	3	29.06	6.8
KCSRGH05010-DIN6	5	1005.31	64	49	49	39	62.83	125.66	8	12	14	20	13	30.1	945.00	11.7	3	29.06	13.7
KCSRGH05020-DIN6	5	2010.62	128	49	49	39	62.83	125.66	16	12	14	20	13	30.1	1950.40	11.7	3	29.06	27.3
KCSRGH06005-DIN6	6	508.94	27	59	59	43	63.62	127.23	4	16	18	26	17	31.4	446.10	15.7	3	41.99	10.5
KCSRGH06010-DIN6	6	1017.88	54	59	59	43	63.62	127.23	8	16	18	26	17	31.4	955.00	15.7	3	41.99	20.9
KCSRGH06020-DIN6	6	2035.75	108	59	59	43	63.62	127.23	16	16	18	26	17	31.4	1973.00	15.7	3	41.99	41.8
KCSRGH08005-DIN6	8	502.65	20	79	79	71	62.83	125.66	4	25	22	33	21	26.6	449.45	19.7	4	74.96	22.3
KCSRGH08005-DIN6	8	1005.31	40	79	79	71	62.83	125.66	8	25	22	33	21	26.6	952.00	19.7	4	74.96	44.6
KCSRGH08020-DIN6	8	2010.61	80	79	79	71	62.83	125.66	16	25	22	33	21	26.6	1957.40	19.7	4	74.96	89.1



KCSRMQ-DIN8

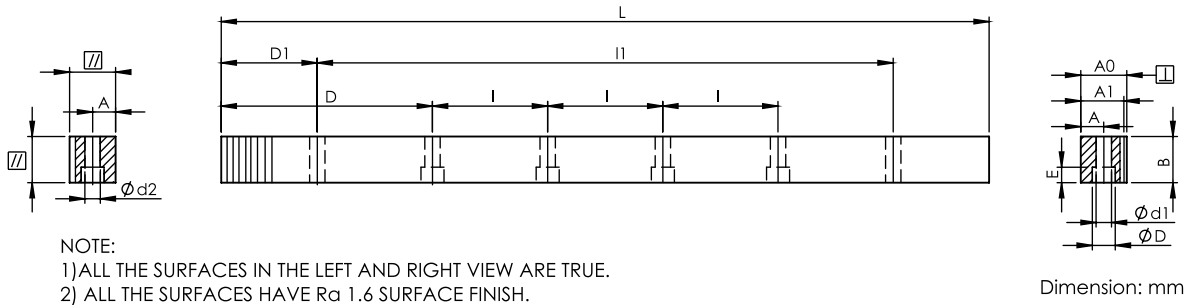

Series KCSRMQ-DIN8 Straight Milled Quenched & Tempered Racks
 Quality Grade DIN 8

Material S50C
 Hardness; HRC 50~55°
 Total Pitch Error: $F_p / 1000 \leq 0.060$ mm
 $F_p / 2000 \leq 0.080$ mm



Code	Module	L	No. of Teeth	B	A0	A1	D	I	No. of Holes	A	Ød1	ØD	E	D1	I1	Ød2	f	F _{ta} kN	KG
KCSRMQ01510-DIN8	1.5	999.03	212	17	17	15.5	62.44	124.88	8	7	6	9.5	7	29	941.00	5.7	1.5	0.35	1.9
KCSRMQ02010-DIN8	2	1005.31	160	25	24	22	62.83	125.66	8	8	7	11	7	31.3	942.70	5.7	2	0.68	4.1
KCSRMQ03010-DIN8	3	1017.88	108	30	29	26	63.62	127.23	8	9	10	15	9	34.4	949.10	7.7	2	1.22	5.9
KCSRMQ04010-DIN8	4	1005.31	80	40	39	35	62.83	125.66	8	12	10	15	9	37.5	930.30	7.7	2	2.18	10.5
KCSRMQ05010-DIN8	5	1005.31	64	49	39	34	62.83	125.66	8	12	14	20	13	30.1	945.00	11.7	3	3.33	12.9
KCSRMQ06010-DIN8	6	1017.88	54	59	49	43	63.62	127.23	8	16	18	26	17	31.4	955.00	15.7	3	4.82	19.7
KCSRMQ08010-DIN8	8	1005.31	40	79	79	71	62.83	125.66	8	25	22	33	21	26.6	952.00	19.7	4	8.60	42.1
KCSRMQ10010-DIN8	10	1005.31	32	99	99	89	62.83	125.66	8	32	33	48	32	125.67	754.00	19.7	5	13.47	66.1



KCSRMH-DIN10

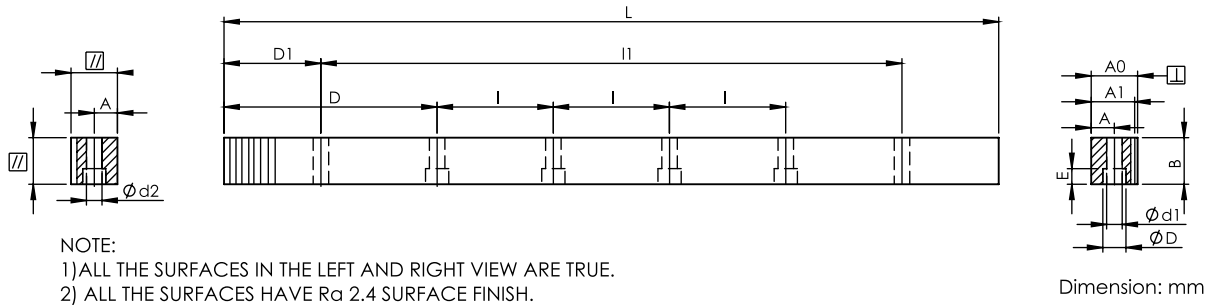

Straight
DIN

Series KCSRMH-DIN10 Straight Hardened Racks
Quality Grade DIN 10

Material S50C
Hardness: HRC 50~55°
Surfaces: Sand-blasted or phosphated.
Total Pitch Error: $F_p/1000 \leq 0.1$ mm

Code	Module	L	No. of Teeth	B	A0	A1	D	I	No. of Holes	A	ød1	øD	E	D1	I1	ød2	f	F _{ta} kN	KG
KCSRMH01510-DIN10	1.5	999.03	212	17	17	15.5	62.44	124.88	8	7	6	9.5	7	29	941.00	5.7	1.5	1.98	1.9
KCSRMH02010-DIN10	2	1005.31	160	24	24	22	62.83	125.66	8	8	7	11	7	31.3	942.70	5.7	2	3.73	3.9
KCSRMH03010-DIN10	3	1017.88	108	29	29	26	63.62	127.23	8	9	10	15	9	34.4	949.10	7.7	2	6.76	5.8
KCSRMH04010-DIN10	4	1005.31	80	39	39	35	62.83	125.66	8	12	10	15	9	37.5	930.30	7.7	2	12.12	10.3
KCSRMH05010-DIN10	5	1005.31	64	49	39	34	62.83	125.66	8	12	14	20	13	30.1	945.00	11.7	3	19.04	12.9
KCSRMH06010-DIN10	6	1017.88	54	59	49	43	63.62	127.23	8	16	18	26	17	31.4	955.00	15.7	3	27.51	19.7
KCSRMH08010-DIN10	8	1005.31	40	79	79	71	62.83	125.66	8	25	22	33	21	26.6	952.00	19.7	4	49.11	42.1
KCSRMH10010-DIN10	10	1005.31	32	99	99	89	62.83	125.66	8	32	33	48	32	125.7	753.96	19.7	4	76.93	66.1

**Content of Guideway Racks**

Code	Material	Type	Type	Shape	Teeth Treatment	Hardness	CP / Module	Grade DIN	Page
KASVGH-CP	SCM440	Straight	V Type Guideway Rack	Hexgan	Teeth Ground	Hardened HRC 53°-58°	CP / 5, 7.5, 10	DIN 6	P.28
KASVGH-CP-L	SCM440	Straight	V Type Guideway Rack	Hexgan	Teeth Ground	Hardened HRC 53°-58°	CP / 5, 7.5, 10	DIN 6	P.29
KCSVM-CP-L	S50C	Straight	V Type Guideway Rack	Hexgan	Milled	HRC 10~12°	CP / 5, 7.5, 10	DIN 8	P.30
KANVGH-00	SCM440	N/A	V Type Guideway	Hexgan	Ground	Hardened HRC 53°-58°	N/A	DIN 6	P.31
KANVGH-L	SCM440	N/A	V Type Guideway	Hexgan	Ground	Hardened HRC 53°-58°	N/A	DIN 6	P.32
KCNVM-L	S50C	N/A	V Type Guideway	Hexgan	Milled	HRC 10~12°	N/A	DIN 8	P.33
KASRGH-CP	SCM440	Straight	Guideway Rack	Rhombus	Teeth Ground	Hardened HRC 53°-58°	CP / 5, 7.5, 10	DIN 6	P.34
KASRGH-CP-L	SCM440	Straight	Guideway Rack	Rhombus	Teeth Ground	Hardened HRC 53°-58°	CP / 5, 7.5, 10	DIN 6	P.35
KCSRML-CP-L	S50C	Straight	Guideway Rack	Rhombus	Milled	HRC 10~12°	CP / 5, 7.5, 10	DIN 8	P.36
KANRGH-00	SCM440	N/A	Guideway	Rhombus	Ground	Hardened HRC 53°-58°	N/A	DIN 6	P.37
KANRGH-L	SCM440	N/A	Guideway	Rhombus	Ground	Hardened HRC 53°-58°	N/A	DIN 6	P.38
KCNRM-L	S50C	N/A	Guideway	Rhombus	Milled	HRC 10~12°	N/A	DIN 8	P.39
KAHVGH-L	SCM440	Helical	V Type Guideway Rack	Hexgan	Teeth Ground	Hardened HRC 53°-58°	M1.5, 2.5, 3	DIN 6	P.40
KCHVM-L	S50C	Helical	V Type Guideway Rack	Hexgan	Milled	HRC 10~12°	M1.5, 2.5, 3	DIN 8	P.41



Guideway Rack Code Instruction



Material	Type	Shape	Teeth Treatment	Hardness	Circular Pitch	Length	Grade
M	S/H	V/R	G	H	CP	L	DIN
C=S50C M=SCM0440	S=Straight N=None H=Helical	V=V Type Bar R=Rhombus	G=Teeth Ground /Ground	H=Hardened	CP=Circular Pitch 00=No Teeth	10=1030 12=1230 or 1200	DIN 6 DIN 8

※Weight only for reference. Actual scale should be Weighing.



KCSVM-CP-L-DIN8

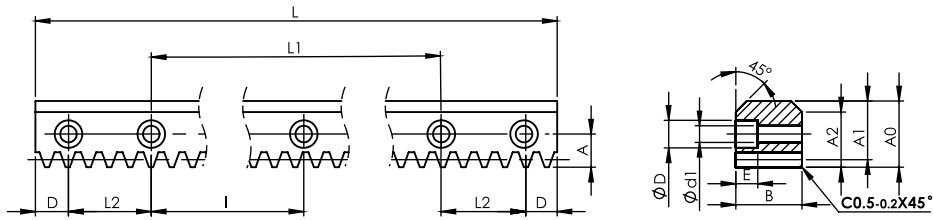

NOTE:
 1) ALL THE SURFACES IN THE RIGHT VIEW ARE TRUE.
 2) ALL THE SURFACES ARE MILLED.

Dimension: mm

Series KCSVM-CP-L-DIN8 Straight V Type Milled Guideway Racks
 Quality Grade DIN 8

Material S50C
 Hardness: HRC 50~55°
 Total Pitch Error: $F_p/1000 \leq 0.060$ mm

Code	CP	No. of Teeth	L	L1	L2	Module	B	A0	A1	D	I	A	φD	φd1	E	A2	F _{ta} kN	KG
KCSVM-CP050-1200-1-DIN8	5	240	1200	1100	35	1.5915	14.5	24.5	22.91	15	100	11.5	11	7	7	20.00	0.31	2.5
KCSVM-CP050-1200-2-DIN8	5	240	1200	1100	35	1.5915	19.5	29.5	27.91	15	100	14.0	15	9	9	23.50	0.42	4.0
KCSVM-CP075-1200-1-DIN8	7.5	160	1200	1100	35	2.3873	24.7	33.0	30.61	15	100	14.5	15	9	9	25.20	0.80	5.5
KCSVM-CP100-1200-1-DIN8	10	120	1200	1100	35	3.1831	34.6	46.6	43.42	15	100	18.0	18	11	11	36.70	1.50	11.4



KCNVM-L-DIN8

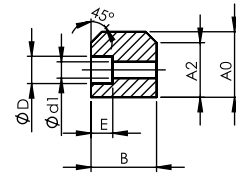
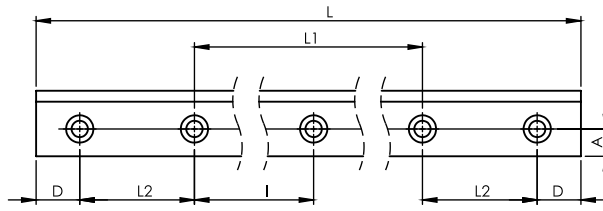

Dimension: mm

NOTE:
 1) ALL THE SURFACES IN THE RIGHT VIEW ARE TRUE.
 2) ALL THE SURFACES ARE MILLED.

Series CNVM-L-DIN8 V Type Milled Guideway
 Quality Grade DIN 8

Material S50C
 Hardness: HRC 50~55°

Code	L	L1	L2	B	A0	D	I	A	ϕD	$\phi d1$	E	A2	KG
KCNVM-1200-1-DIN8	1200	1100	35	14.5	24.5	15	100	11.5	11	7	7	20.0	2.8
KCNVM-1200-2-DIN8	1200	1100	35	19.5	29.5	15	100	14.0	15	9	9	23.5	4.3
KCNVM-1200-3-DIN8	1200	1100	35	24.7	33.0	15	100	14.5	15	9	9	25.2	7.6
KCNVM-1200-4-DIN8	1200	1100	35	34.6	46.6	15	100	18.0	18	11	11	36.7	15.0



KASRGH-CP-DIN6

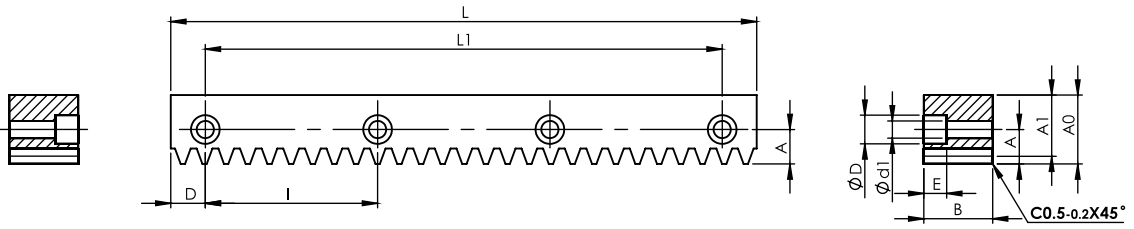

NOTE:
 1) ALL THE SURFACES IN LEFT AND RIGHT VIEW ARE TRUE.
 2) ALL THE SURFACES HAVE Ra 0.8 SURFACE FINISH.
 3) ALL THE SURFACES ARE GROUND.

Dimension: mm

Guideway Racks

Series KASRGH-CP-DIN6 Ground Guideway Racks
Quality Grade DIN 6

Material SCM440
Hardness: HRC 50~55°
4 Sides Ground and Teeth Ground after hardening.
Total Pitch Error: $F_p / 1000 \leq 0.036$ mm

Code	CP	No. of Teeth	L	L1	Module	B	A0	A1	D	I	A	øD	ød1	E	F _{ta} kN	KG
KASRGH-CP05010-1-DIN6	5	206	1030	1000	1.5915	14.5	24.5	22.91	15	100	11.5	11	7	7	2.74	2.2
KASRGH-CP05010-2-DIN6	5	206	1030	1000	1.5915	19.5	29.5	27.91	15	100	14.0	15	9	9	3.68	3.8
KASRGH-CP07512-1-DIN6	7.5	164	1230	1200	2.3873	24.7	33.0	30.61	15	100	14.5	15	9	9	6.99	6.3
KASRGH-CP10012-1-DIN6	10	123	1230	1200	3.1831	34.6	46.6	43.42	15	100	18.0	18	11	11	13.06	12.5



KASRGH-CP-L-DIN6

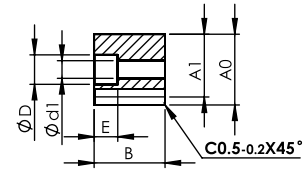
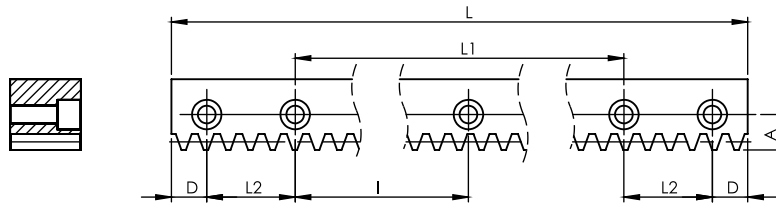

Dimension: mm

NOTE:

- 1) ALL THE SURFACES IN THE LEFT AND RIGHT VIEW ARE TRUE.
- 2) ALL THE SURFACES HAVE Ra 0.8 SURFACE FINISH.
- 3) ALL THE SURFACES ARE GROUND.

Series KASRGH-CP-L-DIN6 Ground Guideway Racks
Quality Grade DIN 6

Material SCM440
Hardness: HRC 50~55°
4 Sides Ground and Teeth Ground after hardening.
Total Pitch Error: $F_p/1000 \leq 0.036$ mm

Code	CP	No. of Teeth	L	L1	L2	Module	B	A0	A1	D	I	A	øD	ød1	E	F _{ta} kN	KG
KASRGH-CP050-1200-1-DIN6	5	240	1200	1100	35	1.5915	14.5	24.5	22.91	15	100	11.5	11	7	7	2.74	2.6
KASRGH-CP050-1200-2-DIN6	5	240	1200	1100	35	1.5915	19.5	29.5	27.91	15	100	14.0	15	9	9	3.68	4.6
KASRGH-CP075-1200-1-DIN6	7.5	160	1200	1100	35	2.3873	24.7	33.0	30.61	15	100	14.5	15	9	9	6.99	7.6
KASRGH-CP100-1200-1-DIN6	10	120	1200	1100	35	3.1831	34.6	46.6	43.42	15	100	18.0	18	11	11	13.06	15.0



KCSRМ-CP-L-DIN8

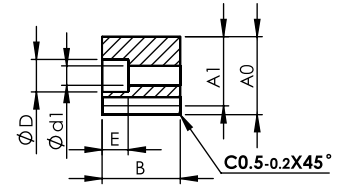
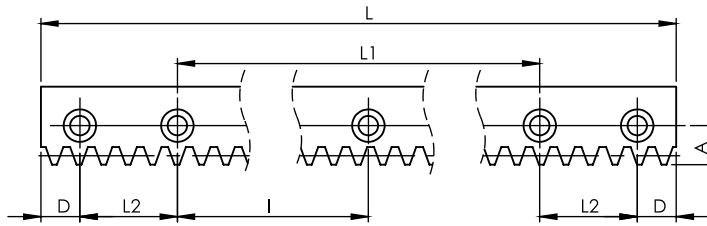

NOTE:
 1) ALL THE SURFACES IN THE LEFT AND RIGHT VIEW ARE TRUE.
 2) ALL THE SURFACES ARE MILLED.

Dimension: mm

Series KCSRМ-CP-L-DIN8 Milled Guideway Racks
 Quality Grade DIN 8

Material S50C
 Hardness: HRC 50~55°
 Total Pitch Error: $F_p/1000 \leq 0.060$ mm

Code	CP	No. of Teeth	L	L1	L2	Module	B	A0	A1	D	I	A	$\varnothing D$	$\varnothing d1$	E	F_{ta} kN	KG
KCSRМ-CP050-1200-1-DIN8	5	240	1200	1100	35	1.5915	14.5	24.5	22.91	15	100	11.5	11	7	7	0.31	2.6
KCSRМ-CP050-1200-2-DIN8	5	240	1200	1100	35	1.5915	19.5	29.5	27.91	15	100	14.0	15	9	9	0.42	4.6
KCSRМ-CP075-1200-1-DIN8	7.5	160	1200	1100	35	2.3873	24.7	33.0	30.61	15	100	14.5	15	9	9	0.80	7.6
KCSRМ-CP100-1200-1-DIN8	10	120	1200	1100	35	3.1831	34.6	46.6	43.42	15	100	18.0	18	11	11	1.50	15.0



KANRGH-00-DIN6

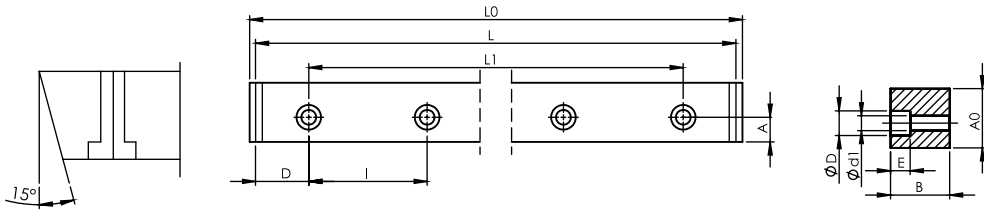

Dimension: mm

- NOTE:
- 1) ALL THE SURFACES IN LEFT AND RIGHT VIEW ARE TRUE.
 - 2) ALL THE SURFACES HAVE Ra 0.8 SURFACE FINISH.
 - 3) ALL THE SURFACES ARE GROUND.

Series KANRGH-00-DIN6 Ground Guideway
Quality Grade DIN 6

Material SCM440
Hardness: HRC 50~55°
4 Sides Ground after hardening.

Guideway Racks

Code	L0	L	L1	B	A0	D	I	A	øD	ød1	E	KG
KANRGH-001-DIN6	1033.89	1030	1000	14.5	24.5	15	100	11.5	11	7	7	2.5
KANRGH-002-DIN6	1035.23	1030	1000	19.5	29.5	15	100	14.0	15	9	9	4.0
KANRGH-003-DIN6	1236.62	1230	1200	24.7	33.0	15	100	14.5	15	9	9	6.8
KANRGH-004-DIN6	1239.27	1230	1200	34.6	46.6	15	100	18.0	18	11	11	13.4



KANRGH-L-DIN6

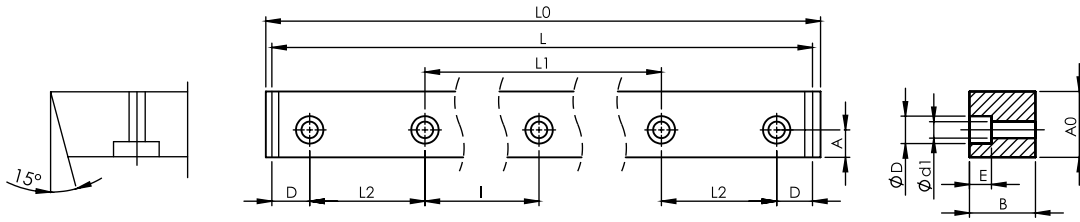

NOTE:
 1) ALL THE SURFACES IN LEFT AND RIGHT VIEW ARE TRUE.
 2) ALL THE SURFACES HAVE Ra 0.8 SURFACE FINISH.
 3) ALL THE SURFACES ARE GROUND.

Dimension: mm

Guideway Racks

Series KANRGH-L-DIN6 Ground Guideway
Quality Grade DIN 6

Material SCM440
Hardness: HRC 50~55°
4 Sides Ground after hardening.

Code	L0	L	L1	L2	B	A0	D	I	A	øD	ød1	E	KG
KANRGH-1200-1-DIN6	1203.89	1200	1100	35	14.5	24.5	15	100	11.5	11	7	7	3.0
KANRGH-1200-2-DIN6	1205.23	1200	1100	35	19.5	29.5	15	100	14.0	15	9	9	4.8
KANRGH-1200-3-DIN6	1206.62	1200	1100	35	24.7	33.0	15	100	14.5	15	9	9	8.2
KANRGH-1200-4-DIN6	1209.27	1200	1100	35	34.6	46.6	15	100	18.0	18	11	11	16.1



KCNRM-L-DIN8

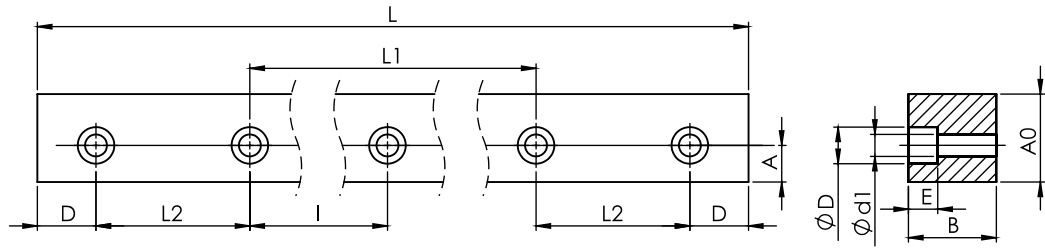

NOTE:
 1) ALL THE SURFACES IN LEFT AND RIGHT VIEW ARE TRUE.
 2) ALL THE SURFACES ARE MILLED.

Dimension: mm

Series KCNRM-L-DIN8 Milled Guideway
 Quality Grade DIN 8

Material S50C
 Hardness: HRC 50~55°



Code	L	L1	L2	B	A0	D	I	A	ϕD	$\phi d1$	E	KG
KCNRM-1200-1-DIN8	1200	1100	35	14.5	24.5	15	100	11.5	11	7	7	3.0
KCNRM-1200-2-DIN8	1200	1100	35	19.5	29.5	15	100	14.0	15	9	9	4.8
KCNRM-1200-3-DIN8	1200	1100	35	24.7	33.0	15	100	14.5	15	9	9	8.2
KCNRM-1200-4-DIN8	1200	1100	35	34.6	46.6	15	100	18.0	18	11	11	16.1

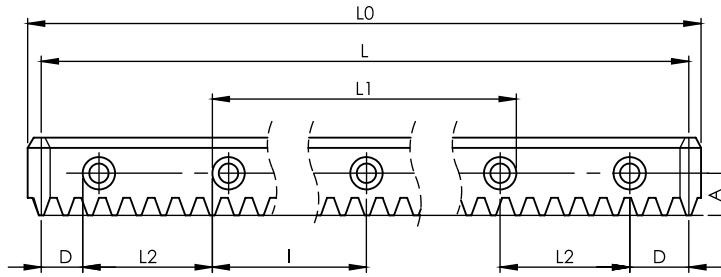
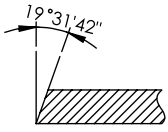

KCHVM-L-DIN8

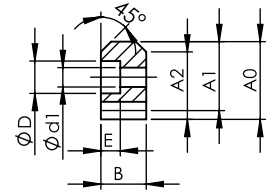

NOTE:
 1) ALL THE SURFACES IN LEFT AND RIGHT VIEW ARE TRUE.
 2) ALL THE SURFACES ARE MILLED.

Dimension: mm

Series KCHVM-L-DIN8 Helical V Type Milled Guideway Racks
 Quality Grade DIN 8

Material S50C
 Right Hand Angle 19°31'42"
 Hardness HRC: 50~55°
 Total Pitch Error: $F_p/1000 \leq 0.060$ mm

Code	Module	No. of Teeth	L0	L	L1	L2	B	A0	A1	D	I	A	øD	ød1	E	A2	F _{ta} kN	KG
KCHVM-015-1200-1-DIN8	1.5	240	1205.14	1200	1100	35	14.5	24.5	23.00	15	100	11.5	11	7	7	20.0	0.54	2.6
KCHVM-015-1200-2-DIN8	1.5	240	1206.92	1200	1100	35	19.5	29.5	28.00	15	100	14.0	15	9	9	23.5	0.73	3.2
KCHVM-025-1200-1-DIN8	2.5	144	1208.76	1200	1100	35	24.7	33.0	30.50	15	100	14.5	15	9	9	25.2	1.54	5.8
KCHVM-030-1200-1-DIN8	3	120	1212.27	1200	1100	35	34.6	46.6	43.60	15	100	18.0	18	11	11	36.7	2.59	11.4



Contents of Pinions

DIN

Code	DIN 3962	Material	Type	Teeth Treatment	Hardness	Module	Page
KAHGH	DIN 6	SCM415 SCM440	Helical Left Hand 19°31'42"	Teeth Ground	HRC 50-55°	1.5, 2, 3, 4, 5, 6, 8, 10	P.44
KAHGH	DIN 6	SCM415 SCM440			HRC 50-55°	1.5, 2.5, 3	P.48
KAHSH	DIN 7	SCM415 SCM440		Skiving	HRC 50-55°	1.5, 2, 3, 4, 5, 6, 8, 10	P.49
KCHM	DIN 8	S45C S50C		Milled	*	1.5, 2, 3, 4, 5, 6, 8, 10	P.52
KMHAH	DIN 10	SCM415 SCM440			HRC 50-55°	1.5, 2, 3, 4, 5, 6, 8, 10	P.55
KASGH	DIN 6	SCM415 SCM440	Straight	Teeth Ground	HRC 50-55°	2, 3, 4, 5, 6, 8	P.58
KASSH	DIN 7	SCM415 SCM440		Skiving	HRC 50-55°	2, 3, 4, 5, 6, 8	P.63
KCSM	DIN 8	S45C S50C		Milled	*	1, 1.5, 2, 2.5, 3, 4, 5, 6, 8, 10	P.68
KMSAH	DIN 10	SCM415 SCM440			HRC 50-55°	1, 1.5, 2, 2.5, 3, 4, 5, 6, 8, 10	P.77
KAHFGH	DIN 6	SCM415 SCM440	Flange Helical	Teeth Ground	HRC 50-55°	2, 3, 4, 5	P.86



Pinions



Pinion Code Instruction



1st	2nd	3rd	4th	5th	6th	7th	8th	9th	10th
Material	Type	Series	Teeth Treatment	Hardness	Module Circular Pitch	No. of Teeth	Series	Fig	Grade
C	S	(F)	G	H	020	030	1	1	DIN JIS
C= Carbon Steel =S45C =S50C A=Alloy Steel =SCM440 =SCM415	S=Straight H=Helical	F=Flange	G=Ground S=Skiving M=Milled	H=Hardened High Frequency Carburized.	M1.5~M10 CP5-CP20	12~120	1~11	1, 2	DI N 6-10 JIS 2-4



KAHGH-DIN6

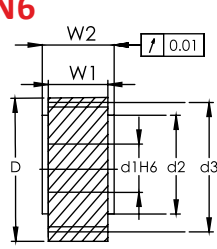

Fig. 1

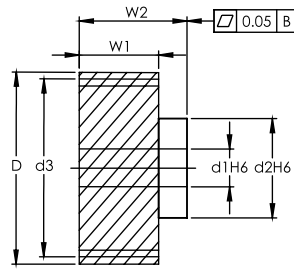
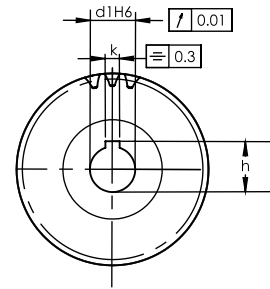

Fig. 2



Dimension: mm

- NOTE:
 1) ALL THE SURFACES IN ALL THE VIEWS ARE TRUE.
 2) ALL THE SURFACES HAVE Ra 0.8 SURFACE FINISH.
 3) ALL THE SURFACES ARE GROUND.

Series KAHGH-DIN6 Helical Teeth Ground Pinions

Quality Grade DIN 6

Material SCM415/SCM440

Left Hand Angle 19°31'42"

Hardness: HRC 50~55°

Teeth Ground after Hardening

Code	Fig.	DIN	No. of Teeth	d1	d2	d3	D	W1	W2	k	h	F _{ta} kN	KG
Module 1.5													
KAHGH0150201	1	-DIN6	20	11	25	31.83	34.83	20	22	4	12.8	4.48	0.10
KAHGH0150202	1	-DIN6	20	13	25	31.83	34.83	20	22	5	15.3	4.48	0.10
KAHGH0150203	1	-DIN6	20	14	25	31.83	34.83	20	22	5	16.3	4.48	0.10
KAHGH0150204	1	-DIN6	20	16	25	31.83	34.83	20	22	5	18.3	4.48	0.10
KAHGH0150205	2	-DIN6	20	16	25	31.83	34.83	20	30	5	18.3	4.48	0.11
KAHGH0150206	2	-DIN6	20	16	24	31.83	34.83	20	50	*	*	4.48	0.15
KAHGH0150211	2	-DIN6	21	16	30	33.42	36.42	20	46	5	18.3	5.29	0.30
KAHGH0150221	2	-DIN6	22	16	25	35.01	38.01	20	30	5	18.3	5.56	0.14
KAHGH0150222	2	-DIN6	22	16	24	35.01	38.01	20	50	*	*	5.56	0.18
KAHGH0150251	2	-DIN6	25	16	30	39.78	42.78	20	46	5	18.3	6.37	0.18
KAHGH0150252	2	-DIN6	25	16	25	39.79	42.79	20	30	5	18.3	6.37	0.18
KAHGH0150253	2	-DIN6	25	16	24	39.79	42.79	20	50	*	*	6.37	0.22
KAHGH0150301	2	-DIN6	30	16	25	47.75	50.75	20	30	5	18.3	7.12	0.27
KAHGH0150302	2	-DIN6	30	16	24	47.75	50.75	20	50	*	*	7.12	0.31
Module 2													
KAHGH0200181	1	-DIN6	18	16	25	38.197	42.20	28	30	5	18.3	7.47	0.20
KAHGH0200201	1	-DIN6	20	19	30	42.44	46.40	28	30	6	21.8	8.36	0.20
KAHGH0200202	2	-DIN6	20	19	30	42.44	46.40	28	56	6	21.8	8.36	0.20
KAHGH0200203	1	-DIN6	20	20	30	42.44	46.40	28	30	6	22.8	8.36	0.20
KAHGH0200204	2	-DIN6	20	22	36	42.44	46.40	28	56	6	24.8	8.36	0.20
KAHGH0200205	1	-DIN6	20	22	30	42.44	46.40	28	30	6	24.8	8.36	0.20
KAHGH0200206	2	-DIN6	20	22	36	42.44	46.40	28	36	6	24.8	8.36	0.20
KAHGH0200207	2	-DIN6	20	22	35	42.44	46.44	25	40	6	24.8	8.36	0.26
KAHGH0200208	2	-DIN6	20	22	30	42.44	46.44	25	60	*	*	8.36	0.29
KAHGH0200211	1	-DIN6	21	16	25	44.56	48.60	28	30	5	18.3	8.81	0.30
KAHGH0200212	2	-DIN6	21	22	36	44.56	48.60	28	30	6	24.8	8.81	0.30
KAHGH0200221	1	-DIN6	22	19	30	46.69	50.70	28	30	6	21.8	10.38	0.30
KAHGH0200222	2	-DIN6	22	19	30	46.69	50.70	28	56	6	21.8	10.38	0.30
KAHGH0200223	1	-DIN6	22	22	30	46.69	50.70	28	30	6	24.8	10.38	0.30
KAHGH0200224	2	-DIN6	22	22	36	46.69	50.70	28	56	6	24.8	10.38	0.30
KAHGH0200225	2	-DIN6	22	22	35	46.69	50.69	25	40	6	24.8	9.27	0.32
KAHGH0200226	2	-DIN6	22	22	35	46.69	50.69	25	60	*	*	9.27	0.35
KAHGH0200251	1	-DIN6	25	19	30	53.05	57.10	28	30	6	21.8	11.90	0.40
KAHGH0200252	2	-DIN6	25	19	30	53.05	57.10	28	56	6	21.8	11.90	0.40
KAHGH0200253	1	-DIN6	25	20	30	53.05	57.10	28	30	6	22.8	11.90	0.40
KAHGH0200254	1	-DIN6	25	22	30	53.05	57.10	28	30	6	24.8	11.90	0.40
KAHGH0200255	2	-DIN6	25	22	36	53.05	57.10	28	56	6	24.8	11.90	0.40
KAHGH0200256	1	-DIN6	25	25	36	53.05	57.10	28	30	6	27.8	11.90	0.40
KAHGH0200257	2	-DIN6	25	22	35	53.05	57.05	25	40	6	24.8	10.62	0.42
KAHGH0200258	2	-DIN6	25	22	30	53.05	57.05	25	60	*	*	10.62	0.45
KAHGH0200281	1	-DIN6	28	19	30	59.42	63.40	28	30	6	21.8	13.06	0.40
KAHGH0200282	2	-DIN6	28	19	30	59.42	63.40	28	56	6	21.8	13.06	0.40
KAHGH0200283	1	-DIN6	28	22	30	59.42	63.40	28	30	6	24.8	13.06	0.40
KAHGH0200284	2	-DIN6	28	22	36	59.42	63.40	28	56	6	24.8	13.06	0.40





KAHGH-DIN6

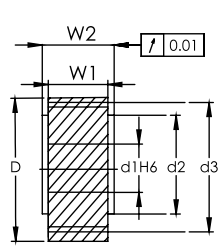

Fig. 1

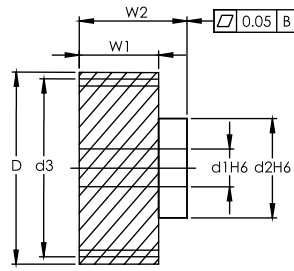
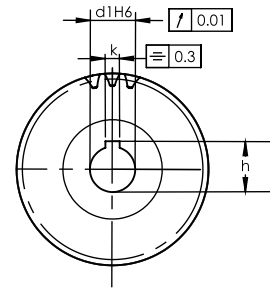

Fig. 2



Dimension: mm

- NOTE:
 1) ALL THE SURFACES IN ALL THE VIEWS ARE TRUE.
 2) ALL THE SURFACES HAVE Ra 0.8 SURFACE FINISH.
 3) ALL THE SURFACES ARE GROUND.

Helical

DIN

Series KAHGH-DIN6 Helical Teeth Ground Pinions

Quality Grade DIN 6

Material SCM415/SCM440

Left Hand Angle 19°31'42"

Hardness: HRC 50~55°

Teeth Ground after Hardening

Code	Fig.	DIN	No. of Teeth	d1	d2	d3	D	W1	W2	k	h	F _{ta} kN	KG
Module 2													
KAHGH0200285	1	-DIN6	28	35	48	59.42	63.40	28	30	10	38.3	13.06	0.40
KAHGH0200301	1	-DIN6	30	16	25	63.66	67.70	28	30	5	18.3	13.30	0.70
KAHGH0200302	1	-DIN6	30	20	30	63.66	67.70	28	30	6	22.8	13.30	0.70
KAHGH0200303	2	-DIN6	30	22	36	63.66	67.70	28	56	6	24.8	13.30	0.70
KAHGH0200304	1	-DIN6	30	25	36	63.66	67.70	28	30	8	28.3	13.30	0.70
KAHGH0200305	1	-DIN6	30	30	45	63.66	67.70	28	30	8	33.3	13.30	0.70
KAHGH0200306	2	-DIN6	30	30	50	63.66	67.70	28	60	8	33.3	13.30	0.70
KAHGH0200307	2	-DIN6	30	32	55	63.66	67.70	28	65	10	35.3	13.30	0.70
KAHGH0200308	2	-DIN6	30	22	35	63.66	67.66	25	40	6	24.8	11.87	0.61
KAHGH0200309	2	-DIN6	30	22	30	63.66	67.66	25	60	*	*	11.87	0.64
KAHGH0200321	1	-DIN6	32	20	30	67.91	71.90	28	30	6	22.8	13.49	0.70
KAHGH0200322	1	-DIN6	32	22	30	67.91	71.90	28	30	6	24.8	13.49	0.70
KAHGH0200323	2	-DIN6	32	22	36	67.91	71.90	28	56	6	24.8	13.49	0.70
KAHGH0200324	1	-DIN6	32	25	36	67.91	71.90	28	30	8	28.3	13.49	0.70
KAHGH0200325	1	-DIN6	32	35	48	67.91	71.90	28	30	10	38.3	13.49	0.70
KAHGH0200361	1	-DIN6	36	35	48	76.39	80.40	28	30	10	38.3	13.84	0.80
KAHGH0200391	2	-DIN6	39	32	55	82.76	86.80	28	65	10	35.3	14.06	1.40
KAHGH0200401	1	-DIN6	40	35	48	84.88	88.90	28	30	10	38.3	14.13	1.20
MODULE 3													
KAHGH0300181	1	-DIN6	18	25	36	54.00	60.00	28	30	8	28.3	12.51	0.40
KAHGH0300201	1	-DIN6	20	25	36	60.00	66.00	28	30	8	28.3	14.00	0.50
KAHGH0300202	2	-DIN6	20	25	44	63.66	69.70	28	60	8	28.3	14.00	1.10
KAHGH0300203	1	-DIN6	20	30	45	63.66	69.70	28	30	8	33.3	14.00	0.50
KAHGH0300204	2	-DIN6	20	30	50	63.66	69.70	28	60	8	33.3	14.00	1.10
KAHGH0300205	2	-DIN6	20	32	55	63.66	69.70	28	65	10	35.3	14.00	1.20
KAHGH0300206	1	-DIN6	20	35	48	63.66	69.70	28	30	10	38.3	14.00	0.50
KAHGH0300207	2	-DIN6	20	22	35	63.66	69.66	30	40	6	24.8	15.06	0.69
KAHGH0300208	2	-DIN6	20	22	30	63.66	69.66	30	65	*	*	15.06	0.74
KAHGH0300209	2	-DIN6	20	32	50	63.66	69.66	30	60	10	35.3	15.06	0.81
KAHGH03002010	2	-DIN6	20	32	44	63.66	69.66	30	70	*	*	15.06	0.78
KAHGH0300221	1	-DIN6	22	25	36	70.03	76.00	28	30	8	28.3	17.65	0.60
KAHGH0300222	1	-DIN6	22	30	45	70.03	76.00	28	30	8	33.3	17.65	0.60
KAHGH0300223	2	-DIN6	22	32	55	70.03	76.00	28	65	10	35.3	17.65	1.40
KAHGH0300224	1	-DIN6	22	35	48	70.03	76.00	28	30	10	38.3	17.65	0.60
KAHGH0300225	2	-DIN6	22	40	62	70.03	76.00	28	65	12	43.3	17.65	1.40
KAHGH0300226	2	-DIN6	22	22	35	70.03	76.03	30	40	6	24.8	16.68	0.85
KAHGH0300227	2	-DIN6	22	22	30	70.03	76.03	30	65	*	*	16.68	0.90
KAHGH0300228	2	-DIN6	22	32	50	70.03	76.03	30	60	10	35.3	16.68	0.96
KAHGH0300229	2	-DIN6	22	32	44	70.03	76.03	30	70	*	*	16.68	0.93
KAHGH0300251	2	-DIN6	25	22	36	79.58	85.60	28	56	6	24.8	19.01	1.50
KAHGH0300252	1	-DIN6	25	25	36	79.58	85.60	28	30	8	28.3	19.01	0.80
KAHGH0300253	2	-DIN6	25	25	44	79.58	85.60	28	60	8	28.3	19.01	1.60
KAHGH0300254	1	-DIN6	25	30	45	79.58	85.60	28	30	8	33.3	19.01	0.80
KAHGH0300255	2	-DIN6	25	30	50	79.58	85.60	28	60	8	33.3	19.01	1.60



KAHGH-DIN6

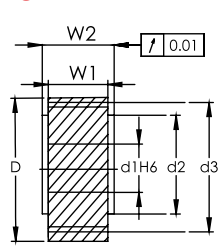

Fig. 1

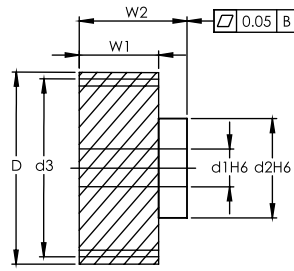
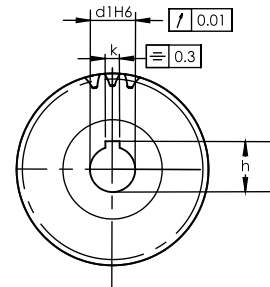

Fig. 2



Dimension: mm

- NOTE:
 1) ALL THE SURFACES IN ALL THE VIEWS ARE TRUE.
 2) ALL THE SURFACES HAVE Ra 0.8 SURFACE FINISH.
 3) ALL THE SURFACES ARE GROUND.

Series KAHGH-DIN6 Helical Teeth Ground Pinions Quality Grade DIN 6

Material SCM415/SCM440
 Left Hand Angle 19°31'42"
 Hardness: HRC 50~55°
 Teeth Ground after Hardening

Code	Fig.	DIN	No. of Teeth	d1	d2	d3	D	W1	W2	k	h	F _{ta} kN	KG
Module 3													
KAHGH0300256	2	-DIN6	25	32	55	79.58	85.60	28	65	10	35.3	19.01	1.80
KAHGH0300257	1	-DIN6	25	35	48	79.58	85.60	28	30	10	38.3	19.01	0.80
KAHGH0300258	2	-DIN6	25	35	55	79.58	85.60	28	65	10	38.3	19.01	1.80
KAHGH0300259	1	-DIN6	25	40	70	79.58	85.60	28	50	12	43.3	19.01	1.40
KAHGH03002510	2	-DIN6	25	40	62	79.58	85.60	28	65	12	43.3	19.01	1.80
KAHGH03002511	2	-DIN6	25	22	35	79.58	85.58	30	40	6	24.8	20.37	1.11
KAHGH03002512	2	-DIN6	25	22	30	79.58	85.58	30	65	*	*	20.37	1.17
KAHGH03002513	2	-DIN6	25	32	50	79.58	85.58	30	60	10	35.3	20.37	1.23
KAHGH03002514	2	-DIN6	25	32	44	79.58	85.58	30	70	*	*	20.37	1.20
KAHGH0300281	2	-DIN6	28	32	55	89.13	95.10	28	65	10	35.3	19.59	2.20
KAHGH0300282	2	-DIN6	28	40	62	89.13	95.10	28	65	12	43.3	19.59	2.20
KAHGH0300301	2	-DIN6	30	22	35	95.49	101.49	30	40	6	24.8	21.37	1.62
KAHGH0300302	2	-DIN6	30	22	30	95.49	101.49	30	65	*	*	21.37	1.67
KAHGH0300303	2	-DIN6	30	32	50	95.49	101.49	30	60	10	35.3	21.37	1.74
KAHGH0300304	2	-DIN6	30	32	44	95.49	101.49	30	70	*	*	21.37	1.71
KAHGH0300321	2	-DIN6	32	32	55	101.86	107.85	28	65	10	35.3	20.24	2.80
KAHGH0300322	2	-DIN6	32	40	62	101.86	107.85	28	65	12	43.3	20.24	2.00
MODULE 4													
KAHGH0400151	1	-DIN6	15	35	52	63.66	71.70	40	50	10	38.3	17.53	0.80
KAHGH0400181	2	-DIN6	18	32	55	76.39	84.40	40	75	10	35.3	23.92	1.60
KAHGH0400201	1	-DIN6	20	35	52	84.88	92.90	40	50	10	38.3	26.78	1.30
KAHGH0400202	1	-DIN6	20	45	65	84.88	92.90	40	50	14	48.8	26.78	1.30
KAHGH0400203	2	-DIN6	20	32	50	84.88	92.88	40	60	10	35.3	26.78	1.67
KAHGH0400204	2	-DIN6	20	32	44	84.88	92.88	40	80	*	*	26.78	1.73
KAHGH0400205	2	-DIN6	20	40	60	84.88	92.88	40	85	12	43.3	26.78	1.89
KAHGH0400206	2	-DIN6	20	40	50	84.88	92.88	40	85	*	*	26.78	1.58
KAHGH0400211	2	-DIN6	21	32	55	89.13	97.10	40	75	10	35.3	28.23	2.20
KAHGH0400212	2	-DIN6	21	35	55	89.13	97.10	40	75	10	38.3	28.23	2.20
KAHGH0400213	2	-DIN6	21	40	62	89.13	97.10	40	75	12	43.3	28.23	2.20
KAHGH0400214	2	-DIN6	21	45	68	89.13	97.10	40	75	14	48.8	28.23	2.20
KAHGH0400221	1	-DIN6	22	35	52	93.37	101.40	40	50	10	38.3	29.66	1.60
KAHGH0400222	1	-DIN6	22	45	65	93.37	101.40	40	50	14	48.8	29.66	1.60
KAHGH0400223	2	-DIN6	22	32	50	93.37	101.37	40	60	10	35.3	29.66	2.04
KAHGH0400224	2	-DIN6	22	32	44	93.37	101.37	40	80	*	*	29.66	2.10
KAHGH0400225	2	-DIN6	22	40	60	93.37	101.37	40	85	12	43.3	29.66	2.26
KAHGH0400226	2	-DIN6	22	40	50	93.37	101.37	40	85	*	*	29.66	1.95
KAHGH0400241	2	-DIN6	24	32	55	101.86	109.90	40	75	10	35.3	35.79	2.80
KAHGH0400242	2	-DIN6	24	35	55	101.86	109.90	40	75	10	38.3	35.79	2.80
KAHGH0400243	2	-DIN6	24	40	62	101.86	109.90	40	75	12	43.3	35.79	2.80
KAHGH0400244	2	-DIN6	24	45	68	101.86	109.90	40	75	14	48.8	35.79	2.80
KAHGH0400245	2	-DIN6	24	55	80	101.86	109.90	40	80	16	59.3	35.79	3.00
KAHGH0400251	1	-DIN6	25	35	52	106.10	114.10	40	50	10	38.3	36.22	2.00
KAHGH0400252	1	-DIN6	25	45	65	106.10	114.10	40	50	14	48.8	36.22	2.00



KAHGH-DIN6

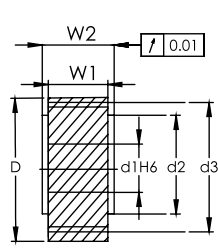

Fig. 1

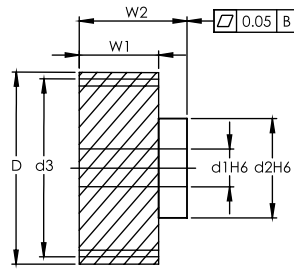
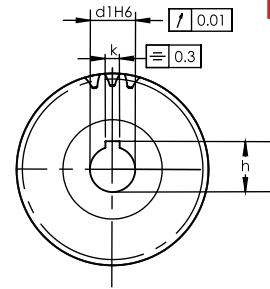

Fig. 2



Dimension: mm

- NOTE:
 1) ALL THE SURFACES IN ALL THE VIEWS ARE TRUE.
 2) ALL THE SURFACES HAVE Ra 0.8 SURFACE FINISH.
 3) ALL THE SURFACES ARE GROUND.

Helical

DIN

Series KAHGH-DIN6 Helical Teeth Ground Pinions Quality Grade DIN 6

Material SCM415/SCM440
 Left Hand Angle 19°31'42"
 Hardness: HRC 50~55°
 Teeth Ground after Hardening

Code	Fig.	DIN	No. of Teeth	d1	d2	d3	D	W1	W2	k	h	F _{ta} kN	KG
Module 4													
KAHGH0400253	2	-DIN6	25	55	80	106.10	114.10	40	80	16	59.3	36.22	3.20
KAHGH0400254	2	-DIN6	25	32	50	106.10	114.10	40	60	10	35.3	36.22	2.66
KAHGH0400255	2	-DIN6	25	32	44	106.10	114.10	40	80	*	*	36.22	2.72
KAHGH0400256	2	-DIN6	25	40	60	106.10	114.10	40	85	12	43.3	36.22	2.88
KAHGH0400257	2	-DIN6	25	40	50	106.10	114.10	40	85	*	*	36.22	2.58
KAHGH0400301	2	-DIN6	30	32	50	127.32	135.32	40	60	10	35.3	38.00	3.88
KAHGH0400302	2	-DIN6	30	32	44	127.32	135.32	40	80	10	*	38.00	3.94
KAHGH0400303	2	-DIN6	30	40	60	127.32	135.32	40	85	12	43.3	38.00	4.10
KAHGH0400304	2	-DIN6	30	40	50	127.32	135.32	40	85	*	*	38.00	3.80
Module 5													
KAHGH0500181	2	-DIN6	18	45	68	95.49	105.50	50	85	14	48.8	37.38	2.90
KAHGH0500201	2	-DIN6	20	40	60	106.10	116.10	50	85	12	43.3	41.84	3.34
KAHGH0500202	2	-DIN6	20	40	50	106.10	116.10	50	90	*	*	41.84	3.16
KAHGH0500221	2	-DIN6	22	40	60	116.71	126.71	50	85	12	43.3	46.34	4.06
KAHGH0500222	2	-DIN6	22	40	50	116.71	126.71	50	90	*	*	46.34	3.88
KAHGH0500241	2	-DIN6	24	45	68	127.32	137.30	50	85	14	48.8	55.93	4.90
KAHGH0500242	2	-DIN6	24	55	80	127.32	137.30	50	90	16	59.3	55.93	5.20
KAHGH0500243	2	-DIN6	24	75	110	127.32	137.30	50	110	20	79.9	55.93	6.40
KAHGH0500251	2	-DIN6	25	40	60	132.63	142.63	50	85	12	43.3	56.58	5.28
KAHGH0500252	2	-DIN6	25	40	50	132.63	142.63	50	90	*	*	56.58	5.10
KAHGH0500301	2	-DIN6	30	40	60	159.16	169.16	50	85	12	43.3	59.37	7.66
KAHGH0500302	2	-DIN6	30	40	50	159.16	169.16	50	90	*	*	59.37	7.48
Module 6													
KAHGH0600201	2	-DIN6	20	55	80	127.32	139.30	60	100	16	59.3	60.26	6.00
KAHGH0600202	2	-DIN6	20	75	110	127.32	139.30	60	120	20	79.9	60.26	7.20
KAHGH0600203	2	-DIN6	20	55	80	127.32	139.32	60	85	16	59.3	60.26	5.28
KAHGH0600204	2	-DIN6	20	55	68	127.32	139.32	60	105	*	*	60.26	5.25
KAHGH0600221	2	-DIN6	22	55	80	140.06	152.06	60	85	16	59.3	66.74	6.53
KAHGH0600222	2	-DIN6	22	55	68	140.06	152.06	60	105	*	*	66.74	6.50
KAHGH0600251	2	-DIN6	25	55	80	159.16	171.20	60	100	16	59.3	81.49	9.00
KAHGH0600252	2	-DIN6	25	75	110	159.16	171.20	60	120	20	79.9	81.49	10.80
KAHGH0600253	2	-DIN6	25	55	80	159.16	171.16	60	85	16	59.3	81.49	8.64
KAHGH0600254	2	-DIN6	25	55	68	159.16	171.16	60	105	*	*	81.49	8.61
KAHGH0600301	2	-DIN6	30	55	80	190.99	212.99	60	85	16	59.3	85.49	12.74
KAHGH0600302	2	-DIN6	30	55	68	190.99	212.99	60	105	*	*	85.49	12.71
Module 8													
KAHGH0800181	2	-DIN6	18	75	110	152.79	168.80	80	140	20	79.9	95.68	11.00
KAHGH0800202	2	-DIN6	20	85	125	169.80	185.80	80	145	22	90.4	107.12	14.00
Module 10													
KAHGH1000201	2	-DIN6	20	85	125	212.21	232.20	100	165	22	90.4	167.38	26.00



KAHGH-L-DIN6

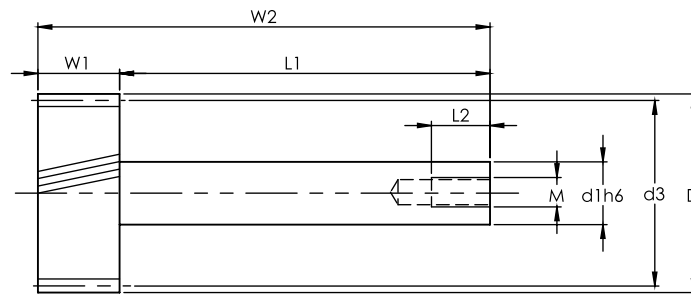

NOTE:
 1) ALL THE SURFACES HAVE Ra 0.8 SURFACE FINISH.
 2) ALL THE SURFACES ARE GROUND.

Dimension: mm

Helical

DIN

Series KAHGH-L-DIN6 Helical Teeth Ground Pinion Shaft
 Quality Grade DIN 6

Material SCM415 / SCM440
 Left Hand Angle 19°31'42"
 Hardness: HRC 50~55°
 Teeth Gound after Hardening

Code	DIN	Module	No. of Teeth	d1	d3	D	W1	W2	L1	L2	Hole	F _{ta} kN	KG
Module 1.5													
KAHGH-L-0150201	-DIN6	1.5	20	20h6	31.831	34.831	11.5	110	98.5	19	M8	2.96	0.5
KAHGH-L-0150202	-DIN6	1.5	20	20h6	31.831	34.831	14.5	90	75.5	19	M8	3.64	0.6
Module 2.5													
KAHGH-L-0250161	-DIN6	2.5	16	25h6	42.441	47.441	19.5	108	88.5	22	M10	5.86	0.6
KAHGH-L-0250181	-DIN6	2.5	18	25h6	47.747	52.747	19.5	108	88.5	22	M10	6.63	0.7
Module 3													
KAHGH-L-0300201	-DIN6	3	20	40h6	63.662	69.662	29.5	162	132.5	28	M12	14.81	1.9
KAHGH-L-0300281	-DIN6	3	28	40h6	89.127	95.127	29.5	162	132.5	28	M12	20.64	2.0



KAHSH-DIN7

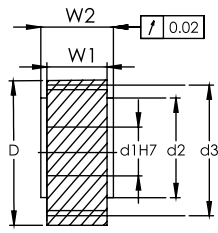

Fig. 1

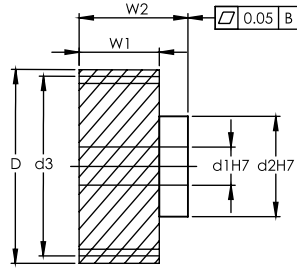
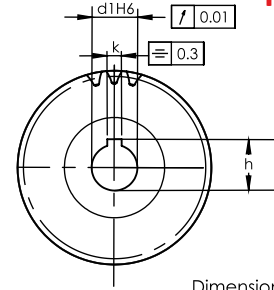

Fig. 2



Dimension: mm

NOTE:
 1) ALL THE SURFACES IN ALL THE VIEWS ARE TRUE.
 2) ALL THE SURFACES HAVE Ra 1.2 SURFACE FINISH.
 3) ALL THE SURFACES ARE GROUND.

Series KAHSH-DIN7 Helical Skiving Pinions
 Quality Grade DIN 7

Material SCM415/SCM440
 Left Hand Angle 19°31'42"
 Hardness: HRC 50~55°
 Skiving after Hardening

Helical

DIN

Code	Fig.	DIN	No. of Teeth	d1	d2	d3	D	W1	W2	k	h	F _{ta} kN	KG
Module 1.5													
KAHSH0150201	1	-DIN7	20	11	25	31.83	34.83	20	22	4	12.8	3.67	0.1
KAHSH0150202	1	-DIN7	20	13	25	31.83	34.83	20	22	5	15.3	3.67	0.1
KAHSH0150203	1	-DIN7	20	14	25	31.83	34.83	20	22	5	16.3	3.67	0.1
KAHSH0150204	1	-DIN7	20	16	25	31.83	34.83	20	22	5	18.3	3.67	0.1
KAHSH0150211	2	-DIN7	21	16	30	33.42	36.42	20	46	5	18.3	4.33	0.3
Module 2													
KAHSH0200181	1	-DIN7	18	16	25	38.197	42.20	28	30	5	18.3	6.12	0.2
KAHSH0200201	1	-DIN7	20	19	30	42.44	46.40	28	30	6	21.8	6.85	0.3
KAHSH0200202	2	-DIN7	20	19	30	42.44	46.40	28	56	6	21.8	6.85	0.6
KAHSH0200203	1	-DIN7	20	20	30	42.44	46.40	28	30	6	22.8	6.85	0.3
KAHSH0200204	2	-DIN7	20	22	36	42.44	46.40	28	56	6	24.8	6.85	0.6
KAHSH0200205	1	-DIN7	20	22	30	42.44	46.40	28	30	6	24.8	6.85	0.3
KAHSH0200211	1	-DIN7	21	16	25	44.56	48.60	28	30	5	18.3	7.22	0.3
KAHSH0200212	2	-DIN7	21	22	36	44.56	48.60	28	30	6	24.8	7.22	0.3
KAHSH0200221	1	-DIN7	22	19	30	46.69	50.70	28	30	6	21.8	8.50	0.4
KAHSH0200222	2	-DIN7	22	19	30	46.69	50.70	28	56	6	21.8	8.50	0.7
KAHSH0200223	1	-DIN7	22	22	30	46.69	50.70	28	30	6	24.8	8.50	0.4
KAHSH0200224	2	-DIN7	22	22	36	46.69	50.70	28	56	6	24.8	8.50	0.7
KAHSH0200251	1	-DIN7	25	19	30	53.05	57.10	28	30	6	21.8	9.75	0.5
KAHSH0200252	2	-DIN7	25	19	30	53.05	57.10	28	56	6	21.8	9.75	0.8
KAHSH0200253	1	-DIN7	25	20	30	53.05	57.10	28	30	6	22.8	9.75	0.5
KAHSH0200254	1	-DIN7	25	22	30	53.05	57.10	28	30	6	24.8	9.75	0.5
KAHSH0200255	2	-DIN7	25	22	36	53.05	57.10	28	56	6	24.8	9.75	0.8
KAHSH0200256	1	-DIN7	25	25	36	53.05	57.10	28	30	6	24.8	9.75	0.5
KAHSH0200281	1	-DIN7	28	19	30	59.42	63.40	28	30	6	21.8	11.00	0.6
KAHSH0200282	2	-DIN7	28	19	30	59.42	63.40	28	56	6	21.8	10.99	1.0
KAHSH0200283	1	-DIN7	28	22	30	59.42	63.40	28	30	6	24.8	10.99	0.6
KAHSH0200284	2	-DIN7	28	22	36	59.42	63.40	28	56	6	24.8	10.99	1.0
KAHSH0200285	1	-DIN7	28	35	48	59.42	63.40	28	30	10	38.3	10.99	0.6
KAHSH0200301	1	-DIN7	30	16	25	63.66	67.70	28	30	5	18.3	11.83	0.6
KAHSH0200302	1	-DIN7	30	20	30	63.66	67.70	28	30	6	22.8	11.83	0.6
KAHSH0200303	2	-DIN7	30	22	36	63.66	67.70	28	56	6	24.8	11.83	1.2
KAHSH0200304	1	-DIN7	30	25	36	63.66	67.70	28	30	8	28.3	11.83	0.6
KAHSH0200305	1	-DIN7	30	30	45	63.66	67.70	28	30	8	33.3	11.83	0.6
KAHSH0200306	2	-DIN7	30	30	50	63.66	67.70	28	60	8	33.3	11.83	1.3
KAHSH0200307	2	-DIN7	30	32	55	63.66	67.70	28	65	10	35.3	11.83	1.4
KAHSH0200321	1	-DIN7	32	20	30	67.91	71.90	28	30	6	22.8	12.37	0.7
KAHSH0200322	1	-DIN7	32	22	30	67.91	71.90	28	30	6	24.8	12.37	0.7
KAHSH0200323	2	-DIN7	32	22	36	67.91	71.90	28	56	6	27.8	12.37	1.3
KAHSH0200324	1	-DIN7	32	25	36	67.91	71.90	28	30	8	28.3	12.37	0.7
KAHSH0200325	1	-DIN7	32	35	48	67.91	71.90	28	30	10	38.3	12.37	0.7
KAHSH0200361	1	-DIN7	36	35	48	76.39	80.40	28	30	10	38.3	12.69	0.9
KAHSH0200391	2	-DIN7	39	32	55	82.76	86.80	28	65	10	35.3	12.89	2.3
KAHSH0200401	1	-DIN7	40	35	48	84.88	88.90	28	30	10	38.3	12.95	1.1



KAHSH-DIN7

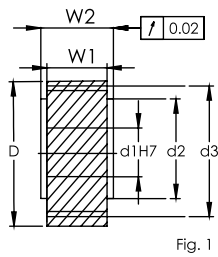

Fig. 1

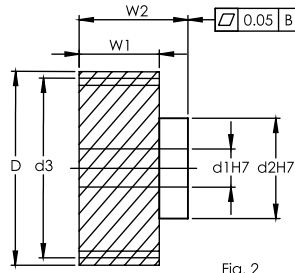
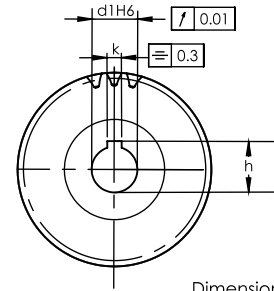

Fig. 2



Dimension: mm

NOTE:
 1) ALL THE SURFACES IN ALL THE VIEWS ARE TRUE.
 2) ALL THE SURFACES HAVE Ra 1.2 SURFACE FINISH.
 3) ALL THE SURFACES ARE GROUND.

Helical

DIN

Series KAHSH-DIN7 Helical Skiving Pinions
 Quality Grade DIN 7

Material SCM415/SCM440
 Left Hand Angle 19°31'42"
 Hardness: HRC 50~55°
 Skiving after Hardening

Code	Fig.	DIN	No. of Teeth	d1	d2	d3	D	W1	W2	k	h	F _{ta} kN	KG
Module 3													
KAHSH0300201	2	-DIN7	20	22	36	63.66	69.70	28	56	6	24.8	11.47	1.0
KAHSH0300202	2	-DIN7	20	25	44	63.66	69.70	28	60	8	28.3	11.47	1.1
KAHSH0300203	1	-DIN7	20	30	45	63.66	69.70	28	30	8	33.3	11.47	0.5
KAHSH0300204	2	-DIN7	20	30	50	63.66	69.70	28	60	8	33.3	11.47	1.1
KAHSH0300205	2	-DIN7	20	32	55	63.66	69.70	28	65	10	35.3	11.47	1.2
KAHSH0300206	1	-DIN7	20	35	48	63.66	69.70	28	30	10	38.3	11.47	0.5
KAHSH0300221	1	-DIN7	22	25	36	70.03	76.00	28	30	8	28.3	14.45	0.6
KAHSH0300222	1	-DIN7	22	30	45	70.03	76.00	28	30	8	33.3	14.45	0.6
KAHSH0300223	2	-DIN7	22	32	55	70.03	76.00	28	65	10	35.3	14.45	1.4
KAHSH0300224	1	-DIN7	22	35	48	70.03	76.00	28	30	10	38.3	14.45	0.6
KAHSH0300225	2	-DIN7	22	40	62	70.03	76.00	28	65	12	43.3	14.45	1.4
KAHSH0300251	2	-DIN7	25	22	36	79.58	85.60	28	56	6	24.8	16.56	1.5
KAHSH0300252	1	-DIN7	25	25	36	79.58	85.60	28	30	8	28.3	16.56	0.8
KAHSH0300253	2	-DIN7	25	25	44	79.58	85.60	28	60	8	28.3	16.56	1.6
KAHSH0300254	1	-DIN7	25	30	45	79.58	85.60	28	30	8	33.3	16.56	0.8
KAHSH0300255	2	-DIN7	25	30	50	79.58	85.60	28	60	8	33.3	16.56	1.6
KAHSH0300256	2	-DIN7	25	32	55	79.58	85.60	28	65	10	35.3	16.56	1.8
KAHSH0300257	1	-DIN7	25	35	48	79.58	85.60	28	30	10	38.3	16.56	0.8
KAHSH0300258	2	-DIN7	25	35	55	79.58	85.60	28	65	10	38.3	16.56	1.8
KAHSH0300259	1	-DIN7	25	40	70	79.58	85.60	28	50	12	43.3	16.56	1.4
KAHSH03002510	2	-DIN7	25	40	62	79.58	85.60	28	65	12	43.3	16.56	1.8
KAHSH0300281	2	-DIN7	28	32	55	89.13	95.10	28	65	10	35.3	17.96	2.2
KAHSH0300282	2	-DIN7	28	40	62	89.13	95.10	28	65	12	43.3	17.96	2.2
KAHSH0300321	2	-DIN7	32	32	55	101.86	107.85	28	65	10	35.3	18.55	2.8
KAHSH0300322	2	-DIN7	32	40	62	101.86	107.85	28	65	12	43.3	18.55	2.8



KAHSH-DIN7

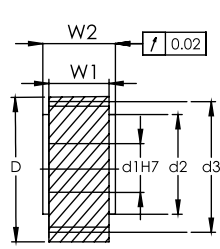

Fig. 1

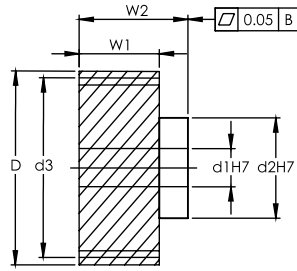
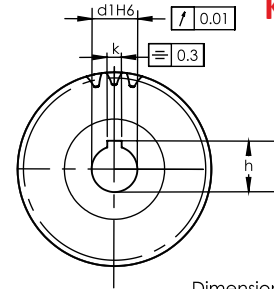

Fig. 2



Dimension: mm

- NOTE:
 1) ALL THE SURFACES IN ALL THE VIEWS ARE TRUE.
 2) ALL THE SURFACES HAVE Ra 1.2 SURFACE FINISH.
 3) ALL THE SURFACES ARE GROUND.

Series KAHSH-DIN7 Helical Skiving Pinions
 Quality Grade DIN 7

Material SCM415/SCM440
 Left Hand Angle 19°31'42"
 Hardness: HRC 50~55°
 Skiving after Hardening

Helical
DIN

Code	Fig.	DIN	No. of Teeth	d1	d2	d3	D	W1	W2	k	h	F _{ta} kN	KG
Module 4													
KAHSH0400151	1	-DIN7	15	35	52	63.66	71.70	40	50	10	38.3	14.36	0.8
KAHSH0400181	2	-DIN7	18	32	55	76.39	84.40	40	75	10	35.3	19.59	1.6
KAHSH0400201	1	-DIN7	20	35	52	84.88	92.90	40	50	10	38.3	21.93	1.3
KAHSH0400202	1	-DIN7	20	45	65	84.88	92.90	40	50	14	48.8	21.93	1.3
KAHSH0400211	2	-DIN7	21	32	55	89.13	97.10	40	75	10	35.3	23.11	2.2
KAHSH0400212	2	-DIN7	21	35	55	89.13	97.10	40	75	10	38.3	23.11	2.2
KAHSH0400213	2	-DIN7	21	40	62	89.13	97.10	40	75	12	43.3	23.11	2.2
KAHSH0400214	2	-DIN7	21	45	68	89.13	97.10	40	75	14	48.8	23.11	2.2
KAHSH0400221	1	-DIN7	22	35	52	93.37	101.40	40	50	10	38.3	24.29	1.6
KAHSH0400222	1	-DIN7	22	45	65	93.37	101.40	40	50	14	48.8	24.29	1.6
KAHSH0400241	2	-DIN7	24	32	55	101.86	109.90	40	75	10	35.3	30.34	2.8
KAHSH0400242	2	-DIN7	24	35	55	101.86	109.90	40	75	10	38.3	30.34	2.8
KAHSH0400243	2	-DIN7	24	40	62	101.86	109.90	40	75	12	43.3	30.34	2.8
KAHSH0400244	2	-DIN7	24	45	68	101.86	109.90	40	75	14	48.8	30.34	2.8
KAHSH0400245	2	-DIN7	24	55	80	101.86	109.90	40	80	16	59.3	30.34	3.0
KAHSH0400251	1	-DIN7	25	35	52	106.10	114.10	40	50	10	38.3	31.68	2.0
KAHSH0400252	1	-DIN7	25	45	65	106.10	114.10	40	50	14	48.8	31.68	2.0
KAHSH0400253	2	-DIN7	25	55	80	106.10	114.10	40	80	16	59.3	31.68	3.2
Module 5													
KAHSH0500181	2	-DIN7	18	45	68	95.49	105.50	50	85	14	48.8	30.61	2.9
KAHSH0500241	2	-DIN7	24	45	68	127.32	137.30	50	85	14	48.8	47.41	4.9
KAHSH0500242	2	-DIN7	24	55	80	127.32	137.30	50	90	16	59.3	47.41	5.2
KAHSH0500243	2	-DIN7	24	75	110	127.32	137.30	50	110	20	79.9	47.41	6.4
Module 6													
KAHSH0600201	2	-DIN7	20	55	80	127.32	139.30	60	100	16	59.3	49.35	6.0
KAHSH0600202	2	-DIN7	20	75	110	127.32	139.30	60	120	20	79.9	49.35	7.2
KAHSH0600251	2	-DIN7	25	55	80	159.16	171.20	60	100	16	59.3	71.29	9.0
KAHSH0600252	2	-DIN7	25	75	110	159.16	171.20	60	120	20	79.9	71.29	10.8
Module 8													
KAHSH0800181	2	-DIN7	18	75	110	152.79	168.80	80	140	20	79.9	78.36	12.3
AHSH0800202	2	-DIN7	20	85	125	169.80	185.80	80	145	22	90.4	87.72	15.4
Module 10													
KAHSH1000201	2	-DIN7	20	85	125	212.21	232.20	100	165	22	90.4	137.07	27.4



KCHM-DIN8

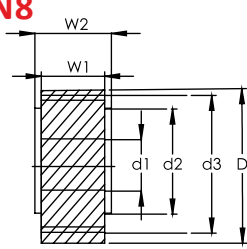

Fig. 1

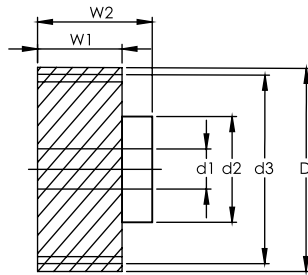
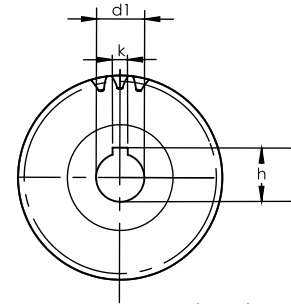

Fig. 2



Dimension: mm

NOTE:
 1) ALL THE SURFACES IN ALL THE VIEWS ARE TRUE.
 2) ALL THE SURFACES HAVE Rg 1.6 SURFACE FINISH.

Helical

DIN

Series KCHM-DIN8 Helical Soft Pinions

Quality Grade DIN 8

Material S45C / S50C

Left Hand Angle 19°31'42"

Code	Fig.	DIN	No. of Teeth	d1	d2	d3	D	W1	W2	k	h	F _{ta} kN	KG
Module 1.5													
KCHM0150201	1	-DIN8	20	11	25	31.83	34.83	20	22	4	12.8	0.51	0.1
KCHM0150202	1	-DIN8	20	13	25	31.83	34.83	20	22	5	15.3	0.51	0.1
KCHM0150203	1	-DIN8	20	14	25	31.83	34.83	20	22	5	16.3	0.51	0.1
KCHM0150204	1	-DIN8	20	16	25	31.83	34.83	20	22	5	18.3	0.51	0.1
KCHM0150211	2	-DIN8	21	16	30	33.42	36.42	20	46	5	18.3	0.61	0.3
Module 2													
KCHM0200181	1	-DIN8	18	16	25	38.197	42.2	28	30	5	18.3	0.86	0.2
KCHM0200201	1	-DIN8	20	19	30	42.44	46.4	28	30	6	21.8	0.96	0.3
KCHM0200202	2	-DIN8	20	19	30	42.44	46.4	28	56	6	21.8	0.96	0.6
KCHM0200203	1	-DIN8	20	20	30	42.44	46.4	28	30	6	22.8	0.96	0.3
KCHM0200204	2	-DIN8	20	22	36	42.44	46.4	28	56	6	24.8	0.96	0.6
KCHM0200205	1	-DIN8	20	22	30	42.44	46.4	28	30	6	24.8	0.96	0.3
KCHM0200211	1	-DIN8	21	16	25	44.56	48.6	28	30	5	18.3	1.01	0.3
KCHM0200212	2	-DIN8	21	22	36	44.56	48.6	28	30	6	24.8	1.01	0.3
KCHM0200221	1	-DIN8	22	19	30	46.69	50.7	28	30	6	21.8	1.19	0.4
KCHM0200222	2	-DIN8	22	19	30	46.69	50.7	28	56	6	21.8	1.19	0.7
KCHM0200223	1	-DIN8	22	22	30	46.69	50.7	28	30	6	24.8	1.19	0.4
KCHM0200224	2	-DIN8	22	22	36	46.69	50.7	28	56	6	24.8	1.19	0.7
KCHM0200251	1	-DIN8	25	19	30	53.05	57.1	28	30	6	21.8	1.37	0.5
KCHM0200252	2	-DIN8	25	19	30	53.05	57.1	28	56	6	21.8	1.37	0.8
KCHM0200253	1	-DIN8	25	20	30	53.05	57.1	28	30	6	22.8	1.37	0.5
KCHM0200254	1	-DIN8	25	22	30	53.05	57.1	28	30	6	24.8	1.37	0.5
KCHM0200255	2	-DIN8	25	22	36	53.05	57.1	28	56	6	24.8	1.37	0.8
KCHM0200256	1	-DIN8	25	25	36	53.05	57.1	28	30	6	27.8	1.37	0.5
KCHM0200281	1	-DIN8	28	19	30	59.42	63.4	28	30	6	21.8	1.54	0.6
KCHM0200282	2	-DIN8	28	19	30	59.42	63.4	28	56	6	21.8	1.54	1.0
KCHM0200283	1	-DIN8	28	22	30	59.42	63.4	28	30	6	24.8	1.54	0.6
KCHM0200284	2	-DIN8	28	22	36	59.42	63.4	28	56	6	24.8	1.54	1.0
KCHM0200285	1	-DIN8	28	35	48	59.42	63.4	28	30	10	38.3	1.54	0.6
KCHM0200301	1	-DIN8	30	16	25	63.66	67.7	28	30	5	18.3	1.66	0.6
KCHM0200302	1	-DIN8	30	20	30	63.66	67.7	28	30	6	22.8	1.66	0.6
KCHM0200303	2	-DIN8	30	22	36	63.66	67.7	28	56	6	24.8	1.66	1.2
KCHM0200304	1	-DIN8	30	25	36	63.66	67.7	28	30	8	28.3	1.66	0.6
KCHM0200305	1	-DIN8	30	30	45	63.66	67.7	28	30	8	33.3	1.66	0.6
KCHM0200306	2	-DIN8	30	30	50	63.66	67.7	28	60	8	33.3	1.66	1.3
KCHM0200307	2	-DIN8	30	32	55	63.66	67.7	28	65	10	35.3	1.66	1.4
KCHM0200321	1	-DIN8	32	20	30	67.91	71.9	28	30	6	22.8	1.78	0.7
KCHM0200322	1	-DIN8	32	22	30	67.91	71.9	28	30	6	24.8	1.78	0.7
KCHM0200323	2	-DIN8	32	22	36	67.91	71.9	28	56	6	27.8	1.78	1.3
KCHM0200324	1	-DIN8	32	25	36	67.91	71.9	28	30	8	28.3	1.78	0.7
KCHM0200325	1	-DIN8	32	35	48	67.91	71.9	28	30	10	38.3	1.78	0.7
KCHM0200361	1	-DIN8	36	35	48	76.39	80.4	28	30	10	38.3	2.29	0.9
KCHM0200391	2	-DIN8	39	32	55	82.76	86.8	28	65	10	35.3	2.49	2.3
KCHM0200401	1	-DIN8	40	35	48	84.88	88.9	28	30	10	38.3	2.56	1.1

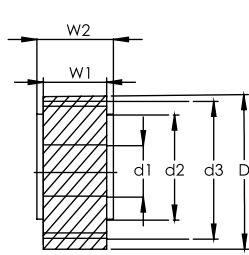

Fig. 1

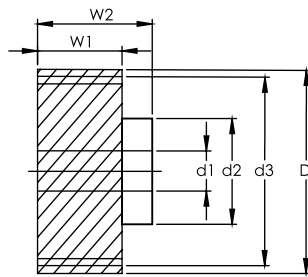
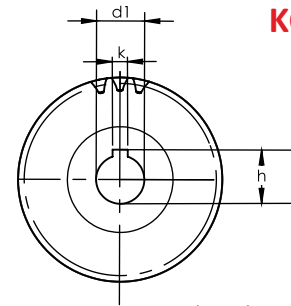

Fig. 2



Dimension: mm

KCHM-DIN8

NOTE:
 1) ALL THE SURFACES IN ALL THE VIEWS ARE TRUE.
 2) ALL THE SURFACES HAVE Rg 1.6 SURFACE FINISH.

Series KCHM-DIN8 Helical Soft Pinions
 Quality Grade DIN 8

Material S45C / S50C
 Left Hand Angle 19°31'42"



Code	Fig.	DIN	No. of Teeth	d1	d2	d3	D	W1	W2	k	h	F _{ta} kN	KG
Module 3													
KCHM0300201	2	-DIN8	20	22	36	63.66	69.7	28	56	6	24.8	1.61	1.0
KCHM0300202	2	-DIN8	20	25	44	63.66	69.7	28	60	8	28.3	1.61	1.1
KCHM0300203	1	-DIN8	20	30	45	63.66	69.7	28	30	8	33.3	1.61	0.5
KCHM0300204	2	-DIN8	20	30	50	63.66	69.7	28	60	8	33.3	1.61	1.1
KCHM0300205	2	-DIN8	20	32	55	63.66	69.7	28	65	10	35.3	1.61	1.2
KCHM0300206	1	-DIN8	20	35	48	63.66	69.7	28	30	10	38.3	1.61	0.5
KCHM0300221	1	-DIN8	22	25	36	70.03	76.0	28	30	8	28.3	2.03	0.6
KCHM0300222	1	-DIN8	22	30	45	70.03	76.0	28	30	8	33.3	2.03	0.6
KCHM0300223	2	-DIN8	22	32	55	70.03	76.0	28	65	10	35.3	2.03	1.4
KCHM0300224	1	-DIN8	22	35	48	70.03	76.0	28	30	10	38.3	2.03	0.6
KCHM0300225	2	-DIN8	22	40	62	70.03	76.0	28	65	12	43.3	2.03	1.4
KCHM0300251	2	-DIN8	25	22	36	79.58	85.6	28	56	6	24.8	2.32	1.5
KCHM0300252	1	-DIN8	25	25	36	79.58	85.6	28	30	8	28.3	2.32	0.8
KCHM0300253	2	-DIN8	25	25	44	79.58	85.6	28	60	8	28.3	2.32	1.6
KCHM0300254	1	-DIN8	25	30	45	79.58	85.6	28	30	8	33.3	2.32	0.8
KCHM0300255	2	-DIN8	25	30	50	79.58	85.6	28	60	8	33.3	2.32	1.6
KCHM0300256	2	-DIN8	25	32	55	79.58	85.6	28	65	10	35.3	2.32	1.8
KCHM0300257	1	-DIN8	25	35	48	79.58	85.6	28	30	10	38.3	2.32	0.8
KCHM0300258	2	-DIN8	25	35	55	79.58	85.6	28	65	10	38.3	2.32	1.8
KCHM0300259	1	-DIN8	25	40	70	79.58	85.6	28	50	12	43.3	2.32	1.4
KCHM03002510	2	-DIN8	25	40	62	79.58	85.6	28	65	12	43.3	2.32	1.8
KCHM0300281	2	-DIN8	28	32	55	89.13	95.1	28	65	10	35.3	2.62	2.2
KCHM0300282	2	-DIN8	28	40	62	89.13	95.1	28	65	12	43.3	2.62	2.2
KCHM0300321	2	-DIN8	32	32	55	101.86	107.85	28	65	10	35.3	3.02	2.8
KCHM0300322	2	-DIN8	32	40	62	101.86	107.85	28	65	12	43.3	3.02	2.8



KCHM-DIN8

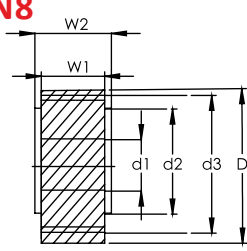

Fig. 1

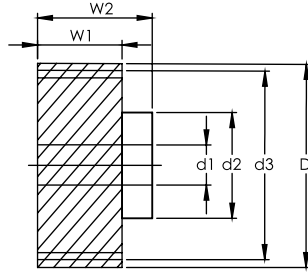
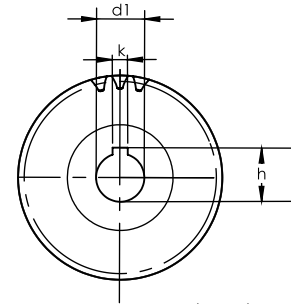

Fig. 2



Dimension: mm

NOTE:
 1) ALL THE SURFACES IN ALL THE VIEWS ARE TRUE.
 2) ALL THE SURFACES HAVE Rg 1.6 SURFACE FINISH.

Helical

DIN

Series KCHM-DIN8 Helical Soft Pinions
 Quality Grade DIN 8

Material S45C / S50C
 Left Hand Angle 19°31'42"

Code	Fig.	DIN	No. of Teeth	d1	d2	d3	D	W1	W2	k	h	F _{ta} kN	KG
Module 4													
KCHM0400151	1	-DIN8	15	35	52	63.66	71.7	40	50	10	38.3	2.01	0.8
KCHM0400181	2	-DIN8	18	32	55	76.39	84.4	40	75	10	35.3	2.74	1.6
KCHM0400201	1	-DIN8	20	35	52	84.88	92.9	40	50	10	38.3	3.07	1.3
KCHM0400202	1	-DIN8	20	45	65	84.88	92.9	40	50	14	48.8	3.07	1.3
KCHM0400211	2	-DIN8	21	32	55	89.13	97.1	40	75	10	35.3	3.24	2.2
KCHM0400212	2	-DIN8	21	35	55	89.13	97.1	40	75	10	38.3	3.24	2.2
KCHM0400213	2	-DIN8	21	40	62	89.13	97.1	40	75	12	43.3	3.24	2.2
KCHM0400214	2	-DIN8	21	45	68	89.13	97.1	40	75	14	48.8	3.24	2.2
KCHM0400221	1	-DIN8	22	35	52	93.37	101.4	40	50	10	38.3	3.40	1.6
KCHM0400222	1	-DIN8	22	45	65	93.37	101.4	40	50	14	48.8	3.40	1.6
KCHM0400241	2	-DIN8	24	32	55	101.86	109.9	40	75	10	35.3	4.25	2.8
KCHM0400242	2	-DIN8	24	35	55	101.86	109.9	40	75	10	38.3	4.25	2.8
KCHM0400243	2	-DIN8	24	40	62	101.86	109.9	40	75	12	43.3	4.25	2.8
KCHM0400244	2	-DIN8	24	45	68	101.86	109.9	40	75	14	48.8	4.25	2.8
KCHM0400245	2	-DIN8	24	55	80	101.86	109.9	40	80	16	59.3	4.25	3.0
KCHM0400251	1	-DIN8	25	35	52	106.1	114.1	40	50	10	38.3	4.44	2.0
KCHM0400252	1	-DIN8	25	45	65	106.1	114.1	40	50	14	48.8	4.44	2.0
KCHM0400253	2	-DIN8	25	55	80	106.1	114.1	40	80	16	59.3	4.44	3.2
Module 5													
KCHM0500181	2	-DIN8	18	45	68	95.49	105.5	50	85	14	48.8	4.29	2.9
KCHM0500241	2	-DIN8	24	45	68	127.32	137.3	50	85	14	48.8	6.64	4.9
KCHM0500242	2	-DIN8	24	55	80	127.32	137.3	50	90	16	59.3	6.64	5.2
KCHM0500243	2	-DIN8	24	75	110	127.32	137.3	50	110	20	79.9	6.64	6.4
Module 6													
KCHM0600201	2	-DIN8	20	55	80	127.32	139.3	60	100	16	59.3	6.91	6.0
KCHM0600202	2	-DIN8	20	75	110	127.32	139.3	60	120	20	79.9	6.91	7.2
KCHM0600251	2	-DIN8	25	55	80	159.16	171.2	60	100	16	59.3	9.99	9.0
KCHM0600252	2	-DIN8	25	75	110	159.16	171.2	60	120	20	79.9	9.99	10.8
Module 8													
KCHM0800181	2	-DIN8	18	75	110	152.79	168.8	80	140	20	79.9	10.98	12.3
KCHM0800202	2	-DIN8	20	85	125	169.8	185.8	80	145	22	90.4	12.29	15.4
Module 10													
KCHM1000201	2	-DIN8	20	85	125	212.21	232.2	100	165	22	90.4	19.20	27.4



KAHMH-DIN10

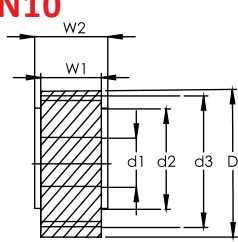

Fig. 1

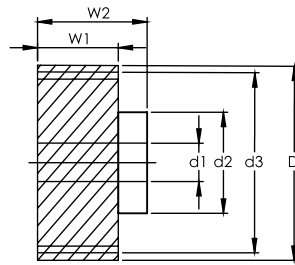
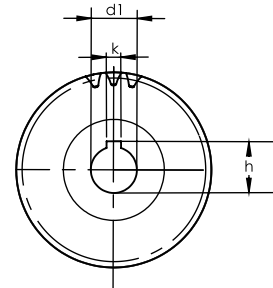

Fig. 2



Dimension: mm

NOTE:
 1) ALL THE SURFACES IN ALL THE VIEWS ARE TRUE.
 2) ALL THE SURFACES HAVE Rg 2.4 SURFACE FINISH.

Series KAHMH-DIN10 Helical Hardened Pinions
 Quality Grade DIN 10

Material SCM415/SCM440
 Left Hand Angle 19°31'42"
 Hardness: HRC 50~55°
 Surfaces: Sand-blasted



Code	Fig.	DIN	No. of Teeth	d1	d2	d3	D	W1	W2	k	h	F _{ta} kN	KG
Module 1.5													
KAHMH0150201	1	-DIN10	20	11	25	31.83	34.83	20	22	4	12.8	2.93	0.1
KAHMH0150202	1	-DIN10	20	13	25	31.83	34.83	20	22	5	15.3	2.93	0.1
KAHMH0150203	1	-DIN10	20	14	25	31.83	34.83	20	22	5	16.3	2.93	0.1
KAHMH0150204	1	-DIN10	20	16	25	31.83	34.83	20	22	5	18.3	2.93	0.1
KAHMH0150211	2	-DIN10	21	16	30	33.42	36.42	20	46	5	18.3	3.47	0.3
Module 2													
KAHMH0200181	1	-DIN10	18	16	25	38.197	42.2	28	30	5	18.3	4.89	0.2
KAHMH0200201	1	-DIN10	20	19	30	42.44	46.4	28	30	6	21.8	5.48	0.3
KAHMH0200202	2	-DIN10	20	19	30	42.44	46.4	28	56	6	21.8	5.48	0.6
KAHMH0200203	1	-DIN10	20	20	30	42.44	46.4	28	30	6	22.8	5.48	0.3
KAHMH0200204	2	-DIN10	20	22	36	42.44	46.4	28	56	6	24.8	5.48	0.6
KAHMH0200205	1	-DIN10	20	22	30	42.44	46.4	28	30	6	24.8	5.48	0.3
KAHMH0200211	1	-DIN10	21	16	25	44.56	48.6	28	30	5	18.3	5.77	0.3
KAHMH0200212	2	-DIN10	21	22	36	44.56	48.6	28	30	6	24.8	5.77	0.3
KAHMH0200221	1	-DIN10	22	19	30	46.69	50.7	28	30	6	21.8	6.80	0.4
KAHMH0200222	2	-DIN10	22	19	30	46.69	50.7	28	56	6	21.8	6.80	0.7
KAHMH0200223	1	-DIN10	22	22	30	46.69	50.7	28	30	6	24.8	6.80	0.4
KAHMH0200224	2	-DIN10	22	22	36	46.69	50.7	28	56	6	24.8	6.80	0.7
KAHMH0200251	1	-DIN10	25	19	30	53.05	57.1	28	30	6	21.8	7.80	0.5
KAHMH0200252	2	-DIN10	25	19	30	53.05	57.1	28	56	6	21.8	7.80	0.8
KAHMH0200253	1	-DIN10	25	20	30	53.05	57.1	28	30	6	22.8	7.80	0.5
KAHMH0200254	1	-DIN10	25	22	30	53.05	57.1	28	30	6	24.8	7.80	0.5
KAHMH0200255	2	-DIN10	25	22	36	53.05	57.1	28	56	6	24.8	7.80	0.8
KAHMH0200256	1	-DIN10	25	25	36	53.05	57.1	28	30	6	27.8	7.80	0.5
KAHMH0200281	1	-DIN10	28	19	30	59.42	63.4	28	30	6	21.8	8.80	0.6
KAHMH0200282	2	-DIN10	28	19	30	59.42	63.4	28	56	6	21.8	8.80	1.0
KAHMH0200283	1	-DIN10	28	22	30	59.42	63.4	28	30	6	24.8	8.80	0.6
KAHMH0200284	2	-DIN10	28	22	36	59.42	63.4	28	56	6	24.8	8.80	1.0
KAHMH0200285	1	-DIN10	28	35	48	59.42	63.4	28	30	10	38.3	8.80	0.6
KAHMH0200301	1	-DIN10	30	16	25	63.66	67.7	28	30	5	18.3	9.47	0.6
KAHMH0200302	1	-DIN10	30	20	30	63.66	67.7	28	30	6	22.8	9.47	0.6
KAHMH0200303	2	-DIN10	30	22	36	63.66	67.7	28	56	6	24.8	9.47	1.2
KAHMH0200304	1	-DIN10	30	25	36	63.66	67.7	28	30	8	28.3	9.47	0.6
KAHMH0200305	1	-DIN10	30	30	45	63.66	67.7	28	30	8	33.3	9.47	0.6
KAHMH0200306	2	-DIN10	30	30	50	63.66	67.7	28	60	8	33.3	9.47	1.3
KAHMH0200307	2	-DIN10	30	32	55	63.66	67.7	28	65	10	35.3	9.47	1.4
KAHMH0200321	1	-DIN10	32	20	30	67.91	71.9	28	30	6	22.8	9.90	0.7
KAHMH0200322	1	-DIN10	32	22	30	67.91	71.9	28	30	6	24.8	9.90	0.7
KAHMH0200323	2	-DIN10	32	22	36	67.91	71.9	28	56	6	27.8	9.90	1.3
KAHMH0200324	1	-DIN10	32	25	36	67.91	71.9	28	30	8	28.3	9.90	0.7
KAHMH0200325	1	-DIN10	32	35	48	67.91	71.9	28	30	10	38.3	9.90	0.7
KAHMH0200361	1	-DIN10	36	35	48	76.39	80.4	28	30	10	38.3	10.15	0.9
KAHMH0200391	2	-DIN10	39	32	55	82.76	86.8	28	65	10	35.3	10.31	2.3
KAHMH0200401	1	-DIN10	40	35	48	84.88	88.9	28	30	10	38.3	10.36	1.1



KAHMH-DIN10

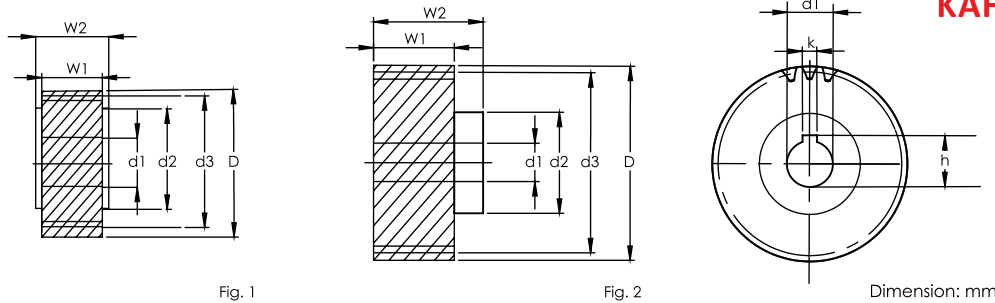

NOTE:
 1) ALL THE SURFACES IN ALL THE VIEWS ARE TRUE.
 2) ALL THE SURFACES HAVE Rg 2.4 SURFACE FINISH.

Helical

DIN

Series KAHMH-DIN10 Helical Hardened Pinions
 Quality Grade DIN 10

Material SCM415/SCM440
 Left Hand Angle 19°31'42"
 Hardness: HRC 50~55°
 Surfaces: Sand-blasted

Code	Fig.	DIN	No. of Teeth	d1	d2	d3	D	W1	W2	k	h	F _{ta} kN	KG
Module 3													
KAHMH0300201	2	-DIN10	20	22	36	63.66	69.7	28	56	6	24.8	9.17	1.0
KAHMH0300202	2	-DIN10	20	25	44	63.66	69.7	28	60	8	28.3	9.17	1.1
KAHMH0300203	1	-DIN10	20	30	45	63.66	69.7	28	30	8	33.3	9.17	0.5
KAHMH0300204	2	-DIN10	20	30	50	63.66	69.7	28	60	8	33.3	9.17	1.1
KAHMH0300205	2	-DIN10	20	32	55	63.66	69.7	28	65	10	35.3	9.17	1.2
KAHMH0300206	1	-DIN10	20	35	48	63.66	69.7	28	30	10	38.3	9.17	0.5
KAHMH0300221	1	-DIN10	22	25	36	70.03	76	28	30	8	28.3	11.56	0.6
KAHMH0300222	1	-DIN10	22	30	45	70.03	76	28	30	8	33.3	11.56	0.6
KAHMH0300223	2	-DIN10	22	32	55	70.03	76	28	65	10	35.3	11.56	1.4
KAHMH0300224	1	-DIN10	22	35	48	70.03	76	28	30	10	38.3	11.56	0.6
KAHMH0300225	2	-DIN10	22	40	62	70.03	76	28	65	12	43.3	11.56	1.4
KAHMH0300251	2	-DIN10	25	22	36	79.58	85.6	28	56	6	24.8	13.25	1.5
KAHMH0300252	1	-DIN10	25	25	36	79.58	85.6	28	30	8	28.3	13.25	0.8
KAHMH0300253	2	-DIN10	25	25	44	79.58	85.6	28	60	8	28.3	13.25	1.6
KAHMH0300254	1	-DIN10	25	30	45	79.58	85.6	28	30	8	33.3	13.25	0.8
KAHMH0300255	2	-DIN10	25	30	50	79.58	85.6	28	60	8	33.3	13.25	1.6
KAHMH0300256	2	-DIN10	25	32	55	79.58	85.6	28	65	10	35.3	13.25	1.8
KAHMH0300257	1	-DIN10	25	35	48	79.58	85.6	28	30	10	38.3	13.25	0.8
KAHMH0300258	2	-DIN10	25	35	55	79.58	85.6	28	65	10	38.3	13.25	1.8
KAHMH0300259	1	-DIN10	25	40	70	79.58	85.6	28	50	12	43.3	13.25	1.4
KAHMH03002510	2	-DIN10	25	40	62	79.58	85.6	28	65	12	43.3	13.25	1.8
KAHMH0300281	2	-DIN10	28	32	55	89.13	95.1	28	65	10	35.3	14.37	2.2
KAHMH0300282	2	-DIN10	28	40	62	89.13	95.1	28	65	12	43.3	14.37	2.2
KAHMH0300321	2	-DIN10	32	32	55	101.86	107.85	28	65	10	35.3	14.84	2.8
KAHMH0300322	2	-DIN10	32	40	62	101.86	107.85	28	65	12	43.3	14.84	2.8



KAHMH-DIN10

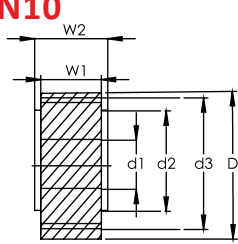

Fig. 1

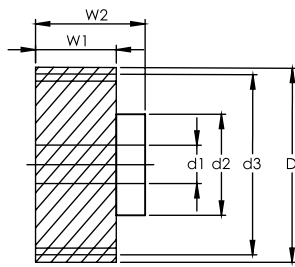
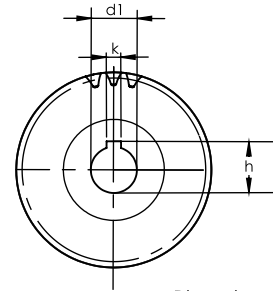

Fig. 2



Dimension: mm

NOTE:
 1) ALL THE SURFACES IN ALL THE VIEWS ARE TRUE.
 2) ALL THE SURFACES HAVE Rg 2.4 SURFACE FINISH.

Series KAHMH-DIN10 Helical Hardened Pinions
 Quality Grade DIN 10

Material SCM415/SCM440
 Left Hand Angle 19°31'42"
 Hardness: HRC 50~55°
 Surfaces: Sand-blasted



Code	Fig.	DIN	No. of Teeth	d1	d2	d3	D	W1	W2	k	h	F _{ta} kN	KG
Module 4													
KAHMH0400151	1	-DIN10	15	35	52	63.66	71.7	40	50	10	38.3	11.49	0.8
KAHMH0400181	2	-DIN10	18	32	55	76.39	84.4	40	75	10	35.3	15.67	1.6
KAHMH0400201	1	-DIN10	20	35	52	84.88	92.9	40	50	10	38.3	17.55	1.3
KAHMH0400202	1	-DIN10	20	45	65	84.88	92.9	40	50	14	48.8	17.55	1.3
KAHMH0400211	2	-DIN10	21	32	55	89.13	97.1	40	75	10	35.3	18.49	2.2
KAHMH0400212	2	-DIN10	21	35	55	89.13	97.1	40	75	10	38.3	18.49	2.2
KAHMH0400213	2	-DIN10	21	40	62	89.13	97.1	40	75	12	43.3	18.49	2.2
KAHMH0400214	2	-DIN10	21	45	68	89.13	97.1	40	75	14	48.8	18.49	2.2
KAHMH0400221	1	-DIN10	22	35	52	93.37	101.4	40	50	10	38.3	19.43	1.6
KAHMH0400222	1	-DIN10	22	45	65	93.37	101.4	40	50	14	48.8	19.43	1.6
KAHMH0400241	2	-DIN10	24	32	55	101.86	109.9	40	75	10	35.3	24.27	2.8
KAHMH0400242	2	-DIN10	24	35	55	101.86	109.9	40	75	10	38.3	24.27	2.8
KAHMH0400243	2	-DIN10	24	40	62	101.86	109.9	40	75	12	43.3	24.27	2.8
KAHMH0400244	2	-DIN10	24	45	68	101.86	109.9	40	75	14	48.8	24.27	2.8
KAHMH0400245	2	-DIN10	24	55	80	101.86	109.9	40	80	16	59.3	24.27	3.0
KAHMH0400251	1	-DIN10	25	35	52	106.1	114.1	40	50	10	38.3	25.35	2.0
KAHMH0400252	1	-DIN10	25	45	65	106.1	114.1	40	50	14	48.8	25.35	2.0
MHMH0400253	2	-DIN10	25	55	80	106.1	114.1	40	80	16	59.3	25.35	3.2
Module 5													
KAHMH0500181	2	-DIN10	18	45	68	95.49	105.5	50	85	14	48.8	24.49	2.9
KAHMH0500241	2	-DIN10	24	45	68	127.32	137.3	50	85	14	48.8	37.93	4.9
KAHMH0500242	2	-DIN10	24	55	80	127.32	137.3	50	90	16	59.3	37.93	5.2
KAHMH0500243	2	-DIN10	24	75	110	127.32	137.3	50	110	20	79.9	37.93	6.4
Module 6													
KAHMH0600201	2	-DIN10	20	55	80	127.32	139.3	60	100	16	59.3	39.48	6.0
KAHMH0600202	2	-DIN10	20	75	110	127.32	139.3	60	120	20	79.9	39.48	7.2
KAHMH0600251	2	-DIN10	25	55	80	159.16	171.2	60	100	16	59.3	57.03	9.0
KAHMH0600252	2	-DIN10	25	75	110	159.16	171.2	60	120	20	79.9	57.03	10.8
Module 8													
KAHMH0800181	2	-DIN10	18	75	110	152.79	168.8	80	140	20	79.9	62.69	12.3
KAHMH0800201	2	-DIN10	20	85	125	169.8	185.8	80	145	22	90.4	70.18	15.4
Module 10													
KAHMH1000201	2	-DIN10	20	85	125	212.21	232.2	100	165	22	90.4	109.7	27.4



KASGH-DIN6

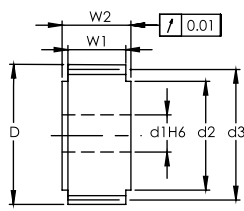

Fig. 1

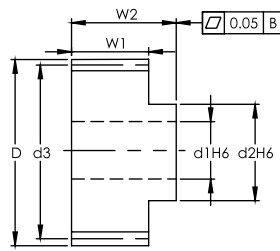
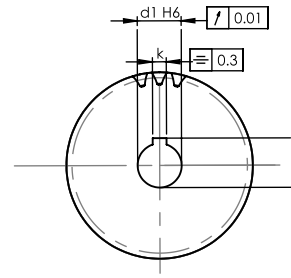

Fig. 2



Dimension: mm

NOTE:
 1) ALL THE SURFACES IN ALL THE VIEWS ARE TRUE.
 2) ALL THE SURFACES HAVE R_a 0.8 SURFACE FINISH.
 3) ALL THE SURFACES ARE GROUND.

Straight

DIN

Series KASGH-DIN6 Straight Teeth Ground Pinions Quality Grade DIN 6

Material SCM415/SCM440
 Hardness: HRC 50~55°
 Teeth Ground after Hardening

Code	Fig.	DIN	No. of Teeth	d1	d2	d3	D	W1	W2	k	h	F _{ta} kN	KG
Module 2													
KASGH0200161	1	-DIN6	16	15	25	32	36	28	30	5	17.3	3.32	0.2
KASGH0200181	1	-DIN6	18	15	30	36	40	28	30	5	17.3	4.04	0.2
KASGH0200182	1	-DIN6	18	20	25	36	40	28	30	6	22.8	4.04	0.2
KASGH0200201	1	-DIN6	20	15	25	40	44	28	30	6	17.8	4.49	0.3
KASGH0200202	1	-DIN6	20	19	30	40	44	28	30	6	21.8	4.49	0.3
KASGH0200203	2	-DIN6	20	19	30	40	44	28	56	6	21.8	4.49	0.5
KASGH0200204	1	-DIN6	20	20	30	40	44	28	30	6	22.8	4.49	0.3
KASGH0200205	1	-DIN6	20	22	30	40	44	28	30	6	24.8	4.49	0.3
KASGH0200206	2	-DIN6	20	22	36	40	44	28	56	6	24.8	4.49	0.5
KASGH0200221	1	-DIN6	22	15	25	44	48	28	30	5	17.3	4.94	0.3
KASGH0200222	1	-DIN6	22	19	30	44	48	28	30	6	21.8	4.94	0.3
KASGH0200223	2	-DIN6	22	19	30	44	48	28	56	6	21.8	4.94	0.6
KASGH0200224	1	-DIN6	22	20	30	44	48	28	30	6	22.8	4.94	0.3
KASGH0200225	2	-DIN6	22	22	36	44	48	28	56	6	24.8	4.94	0.6
KASGH0200226	1	-DIN6	22	22	30	44	48	28	30	6	24.8	4.94	0.3
KASGH0200227	1	-DIN6	22	25	36	44	48	28	30	8	28.3	4.94	0.3
KASGH0200251	2	-DIN6	25	16	30	50	54	28	54	5	18.3	6.29	0.7
KASGH0200252	1	-DIN6	25	19	30	50	54	28	30	6	21.8	6.29	0.4
KASGH0200253	2	-DIN6	25	19	30	50	54	28	56	6	21.8	6.29	0.8
KASGH0200254	1	-DIN6	25	20	30	50	54	28	30	6	22.8	6.29	0.4
KASGH0200255	1	-DIN6	25	22	30	50	54	28	30	6	24.8	6.29	0.4
KASGH0200256	2	-DIN6	25	22	36	50	54	28	56	6	24.8	6.29	0.8
KASGH0200257	1	-DIN6	25	25	36	50	54	28	30	8	28.3	6.29	0.4
KASGH0200258	1	-DIN6	25	30	45	50	54	28	30	8	33.3	6.29	0.4
KASGH0200281	1	-DIN6	28	19	30	56	60	28	30	6	21.8	7.05	0.5
KASGH0200282	2	-DIN6	28	19	30	56	60	28	56	6	21.8	7.05	0.9
KASGH0200283	1	-DIN6	28	20	30	56	60	28	30	6	22.8	7.05	0.5
KASGH0200284	1	-DIN6	28	22	30	56	60	28	30	6	24.8	7.05	0.5
KASGH0200285	2	-DIN6	28	22	36	56	60	28	56	6	24.8	7.05	0.9
KASGH0200286	1	-DIN6	28	25	36	56	60	28	30	8	28.3	7.05	0.5
KASGH0200287	1	-DIN6	28	30	45	56	60	28	30	8	33.3	7.05	0.5
KASGH0200288	2	-DIN6	28	30	50	56	60	28	60	8	33.3	7.05	1.0
KASGH0200289	1	-DIN6	28	35	48	56	60	28	30	10	38.3	7.05	0.5
KASGH0200321	2	-DIN6	32	16	30	64	68	28	54	5	18.3	8.05	1.2
KASGH0200322	1	-DIN6	32	20	30	64	68	28	30	6	22.8	8.05	0.6
KASGH0200323	1	-DIN6	32	22	30	64	68	28	30	6	24.8	8.05	0.6
KASGH0200324	2	-DIN6	32	22	36	64	68	28	56	6	24.8	8.05	1.2
KASGH0200325	1	-DIN6	32	25	36	64	68	28	30	8	28.3	8.05	0.6
KASGH0200326	1	-DIN6	32	30	45	64	68	28	30	8	33.3	8.05	0.6
KASGH0200327	2	-DIN6	32	30	50	64	68	28	60	8	33.3	8.05	1.3
KASGH0200328	2	-DIN6	32	32	55	64	68	28	65	10	35.3	8.05	1.4
KASGH0200329	1	-DIN6	32	35	48	64	68	28	30	10	38.3	8.05	0.6
KASGH0200361	1	-DIN6	36	20	30	72	76	28	30	6	22.8	10.31	0.8



KASGH-DIN6

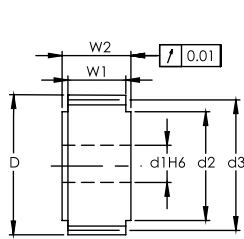

Fig. 1

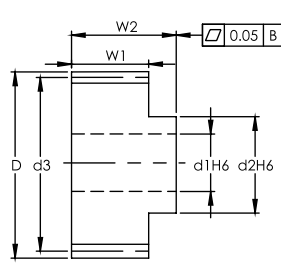
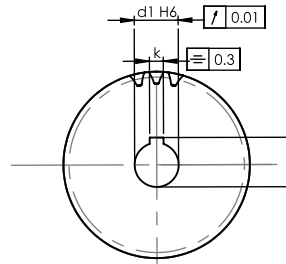

Fig. 2



Dimension: mm

NOTE:
 1) ALL THE SURFACES IN ALL THE VIEWS ARE TRUE.
 2) ALL THE SURFACES HAVE R_a 0.8 SURFACE FINISH.
 3) ALL THE SURFACES ARE GROUND.

Series KASGH-DIN6 Straight Teeth Ground Pinions
 Quality Grade DIN 6

Material SCM415/SCM440
 Hardness: HRC 50~55°
 Teeth Ground after Hardening



Code	Fig.	DIN	No. of Teeth	d1	d2	d3	D	W1	W2	k	h	F _{ta} kN	KG
Module 2													
KASGH0200362	1	-DIN6	36	25	36	72	76	28	30	8	28.3	10.31	0.8
KASGH0200363	1	-DIN6	36	30	45	72	76	28	30	8	33.3	10.31	0.8
KASGH0200364	1	-DIN6	36	35	48	72	76	28	30	10	38.3	10.31	0.8
KASGH0200365	2	-DIN6	36	40	62	72	76	28	65	12	43.3	10.31	1.7
KASGH0200366	1	-DIN6	36	45	58	72	76	28	30	14	48.8	10.31	0.8
KASGH0200401	1	-DIN6	40	15	36	80	84	28	30	5	17.3	11.45	1.0
KASGH0200402	1	-DIN6	40	20	30	80	84	28	30	6	22.8	11.45	1.0
KASGH0200403	1	-DIN6	40	25	36	80	84	28	30	8	28.3	11.45	1.0
KASGH0200404	1	-DIN6	40	30	45	80	84	28	30	8	33.3	11.45	1.0
KASGH0200405	2	-DIN6	40	32	55	80	84	28	65	10	35.3	11.45	2.1
KASGH0200406	1	-DIN6	40	35	48	80	84	28	30	10	38.3	11.45	1.0
KASGH0200407	2	-DIN6	40	40	62	80	84	28	65	12	43.3	11.45	2.1
KASGH0200408	1	-DIN6	40	45	58	80	84	28	30	14	48.8	11.45	1.0
KASGH0200409	2	-DIN6	40	45	68	80	84	28	65	14	48.8	11.45	2.1
KASGH0200451	1	-DIN6	45	20	30	90	94	28	30	6	22.8	11.73	1.2
KASGH0200452	1	-DIN6	45	25	36	90	94	28	30	8	28.3	11.73	1.2
KASGH0200453	1	-DIN6	45	35	48	90	94	28	30	10	38.3	11.73	1.2
KASGH0200454	1	-DIN6	45	45	58	90	94	28	30	14	48.8	11.73	1.2
KASGH0200501	1	-DIN6	50	20	30	100	104	28	30	6	22.8	11.96	1.5
KASGH0200502	1	-DIN6	50	25	36	100	104	28	30	8	28.3	11.96	1.5
KASGH0200503	1	-DIN6	50	35	48	100	104	28	30	10	38.3	11.96	1.5
KASGH0200504	1	-DIN6	50	45	58	100	104	28	30	14	48.8	11.96	1.5
KASGH0200505	2	-DIN6	50	45	68	100	104	28	65	14	48.8	11.96	3.3
KASGH0200561	1	-DIN6	56	25	36	112	116	28	30	8	28.3	12.17	1.9
KASGH0200562	1	-DIN6	56	35	48	112	116	28	30	10	38.3	12.17	1.9



KASGH-DIN6

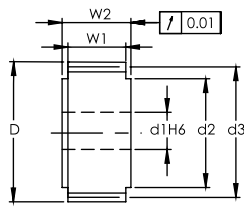

Fig. 1

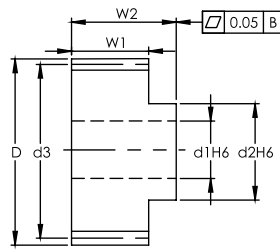
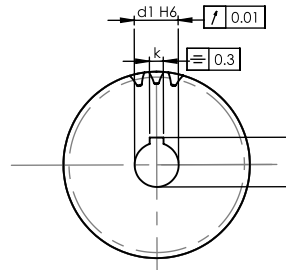

Fig. 2



Dimension: mm

- NOTE:
 1) ALL THE SURFACES IN ALL THE VIEWS ARE TRUE.
 2) ALL THE SURFACES HAVE R_a 0.8 SURFACE FINISH.
 3) ALL THE SURFACES ARE GROUND.

Straight

DIN

Series KASGH-DIN6 Straight Teeth Ground Pinions Quality Grade DIN 6

Material SCM415/SCM440
 Hardness: HRC 50~55°
 Teeth Ground after Hardening

Code	Fig.	DIN	No. of Teeth	d1	d2	d3	D	W1	W2	k	h	F _{ta} kN	KG
Module 3													
KASGH0300181	1	-DIN6	18	25	36	54	60	28	30	8	28.3	6.79	0.4
KASGH0300201	1	-DIN6	20	25	36	60	66	28	30	8	28.3	7.55	0.5
KASGH0300202	1	-DIN6	20	30	45	60	66	28	30	8	33.3	7.55	0.5
KASGH0300203	1	-DIN6	20	35	48	60	66	28	30	10	38.3	7.55	0.5
KASGH0300221	2	-DIN6	22	22	36	66	72	28	56	6	24.8	8.30	1.1
KASGH0300222	1	-DIN6	22	25	36	66	72	28	30	8	28.3	8.30	0.6
KASGH0300223	2	-DIN6	22	25	44	66	72	28	60	8	28.3	8.30	1.2
KASGH0300224	1	-DIN6	22	30	45	66	72	28	30	8	33.3	8.30	0.6
KASGH0300225	2	-DIN6	22	32	55	66	72	28	65	10	35.3	8.30	1.2
KASGH0300226	2	-DIN6	22	30	50	66	72	28	60	8	33.3	8.30	1.2
KASGH0300227	1	-DIN6	22	35	48	66	72	28	30	10	38.3	8.30	0.6
KASGH0300228	2	-DIN6	22	35	55	66	72	28	65	10	38.3	8.30	1.2
KASGH0300229	2	-DIN6	22	40	62	66	72	28	65	12	43.3	8.30	1.2
KASGH0300251	1	-DIN6	25	25	36	75	81	28	30	8	28.3	10.74	0.7
KASGH0300252	1	-DIN6	25	30	45	75	81	28	30	8	33.3	10.74	0.7
KASGH0300253	2	-DIN6	25	32	55	75	81	28	65	10	35.3	10.74	1.6
KASGH0300254	1	-DIN6	25	35	48	75	81	28	30	10	38.3	10.74	0.7
KASGH0300255	2	-DIN6	25	40	62	75	81	28	65	12	43.3	10.74	1.6
KASGH0300256	1	-DIN6	25	45	58	75	81	28	30	14	48.8	10.74	0.7
KASGH0300281	2	-DIN6	28	22	36	84	90	28	56	6	24.8	12.02	1.7
KASGH0300282	1	-DIN6	28	25	36	84	90	28	30	8	28.3	12.02	0.9
KASGH0300283	2	-DIN6	28	25	44	84	90	28	60	8	28.3	12.02	1.8
KASGH0300284	1	-DIN6	28	30	45	84	90	28	30	8	33.3	12.02	0.9
KASGH0300285	2	-DIN6	28	30	50	84	90	28	60	8	33.3	12.02	1.8
KASGH0300286	2	-DIN6	28	32	55	84	90	28	65	10	35.3	12.02	1.9
KASGH0300287	1	-DIN6	28	35	48	84	90	28	30	10	38.3	12.02	0.9
KASGH0300288	2	-DIN6	28	35	55	84	90	28	65	10	38.3	12.02	1.9
KASGH0300289	2	-DIN6	28	40	62	84	90	28	65	12	43.3	12.02	1.9
KASGH03002810	1	-DIN6	28	45	58	84	90	28	30	14	48.8	12.02	0.9
KASGH03002811	2	-DIN6	28	45	68	84	90	28	65	14	48.8	12.02	1.9
KASGH0300321	1	-DIN6	32	25	36	96	102	28	30	8	28.3	13.74	1.2
KASGH0300322	1	-DIN6	32	30	45	96	102	28	30	8	33.3	13.74	1.2
KASGH0300323	2	-DIN6	32	32	55	96	102	28	65	10	35.3	13.74	2.5
KASGH0300324	1	-DIN6	32	35	48	96	102	28	30	10	38.3	13.74	1.2
KASGH0300325	2	-DIN6	32	40	62	96	102	28	65	12	43.3	13.74	2.5
KASGH0300326	1	-DIN6	32	45	58	96	102	28	30	14	48.8	13.74	1.2
KASGH0300327	1	-DIN6	32	60	80	96	102	28	30	18	64.4	13.74	1.2
KASGH0300361	1	-DIN6	36	25	36	108	114	28	30	8	28.3	15.46	1.4
KASGH0300362	1	-DIN6	36	35	48	108	114	28	30	10	38.3	15.46	1.4
KASGH0300363	1	-DIN6	36	45	58	108	114	28	30	14	48.8	15.46	1.4
KASGH0300364	2	-DIN6	36	45	68	108	114	28	65	14	48.8	15.46	1.3
KASGH0300365	1	-DIN6	36	60	80	108	114	28	30	18	64.4	15.46	1.4
KASGH0300401	1	-DIN6	40	25	36	120	126	28	30	8	28.3	17.18	1.8



KASGH-DIN6

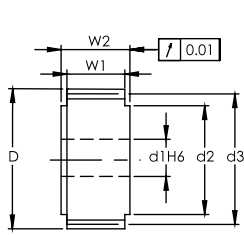

Fig. 1

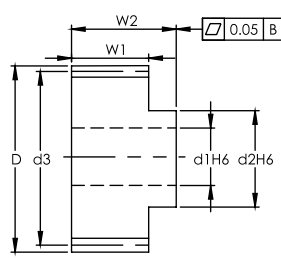
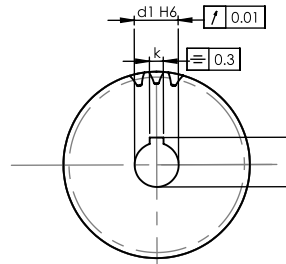

Fig. 2



Dimension: mm

- NOTE:
- 1) ALL THE SURFACES IN ALL THE VIEWS ARE TRUE.
 - 2) ALL THE SURFACES HAVE R_a 0.8 SURFACE FINISH.
 - 3) ALL THE SURFACES ARE GROUND.

Series KASGH-DIN6 Straight Teeth Ground Pinions
Quality Grade DIN 6

Material SCM415/SCM440
Hardness: HRC 50~55°
Teeth Ground after Hardening

Straight
DIN

Code	Fig.	DIN	No. of Teeth	d1	d2	d3	D	W1	W2	k	h	F _{ta} kN	KG
Module 3													
KASGH0300402	1	-DIN6	40	35	48	120	126	28	30	10	38.3	17.18	1.8
KASGH0300403	1	-DIN6	40	45	58	120	126	28	30	14	48.8	17.18	1.8
KASGH0300404	1	-DIN6	40	60	80	120	126	28	30	18	64.4	17.18	1.8
KASGH0300451	1	-DIN6	45	25	36	135	141	28	30	8	28.3	17.60	2.2
KASGH0300452	1	-DIN6	45	35	48	135	141	28	30	10	38.3	17.60	2.2
KASGH0300453	1	-DIN6	45	45	58	135	141	28	30	14	48.8	17.60	2.2
KASGH0300454	1	-DIN6	45	60	80	135	141	28	30	18	64.4	17.60	2.2
KASGH0300501	1	-DIN6	50	35	48	150	156	28	30	10	38.3	17.94	2.7
KASGH0300502	1	-DIN6	50	45	58	150	156	28	30	14	48.8	17.94	2.7
KASGH0300561	1	-DIN6	56	45	58	168	174	28	30	14	48.8	18.25	3.4
KASGH0300631	1	-DIN6	63	45	58	189	195	28	30	14	48.8	18.57	4.2
KASGH0300632	1	-DIN6	63	60	80	189	195	28	30	18	64.4	18.57	4.2



KASGH-DIN6

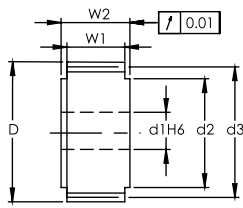

Fig. 1

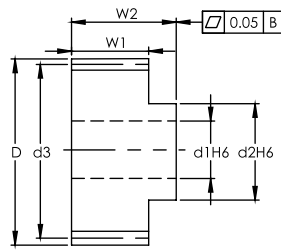
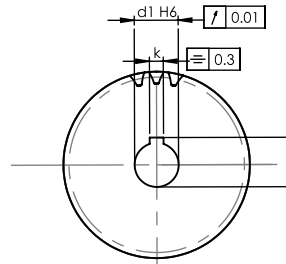

Fig. 2



Dimension: mm

NOTE:
 1) ALL THE SURFACES IN ALL THE VIEWS ARE TRUE.
 2) ALL THE SURFACES HAVE R_a 0.8 SURFACE FINISH.
 3) ALL THE SURFACES ARE GROUND.

Straight

DIN

Series KASGH-DIN6 Straight Teeth Ground Pinions
 Quality Grade DIN 6

Material SCM415/SCM440
 Hardness: HRC 50~55°
 Teeth Ground after Hardening

Code	Fig.	DIN	No. of Teeth	d1	d2	d3	D	W1	W2	k	h	F _{ta} kN	KG
Module 4													
KASGH0400181	1	-DIN6	18	32	55	72	80	40	75	10	35.3	12.93	1.2
KASGH0400201	2	-DIN6	20	32	55	80	88	40	75	10	35.3	14.37	1.8
KASGH0400202	1	-DIN6	20	35	52	80	88	40	50	10	38.3	14.37	1.2
KASGH0400203	2	-DIN6	20	35	55	80	88	40	75	10	38.3	14.37	1.8
KASGH0400204	1	-DIN6	20	45	65	80	88	40	50	14	48.8	14.37	1.2
KASGH0400205	2	-DIN6	20	40	62	80	88	40	75	12	43.3	14.37	1.8
KASGH0400221	1	-DIN6	22	35	52	88	96	40	50	10	38.3	15.81	1.4
KASGH0400222	1	-DIN6	22	45	65	88	96	40	50	14	48.8	15.81	1.4
KASGH0400223	2	-DIN6	22	45	68	88	96	40	75	14	48.8	15.81	2.1
KASGH0400251	2	-DIN6	25	32	55	100	108	40	75	10	35.3	20.45	2.7
KASGH0400252	1	-DIN6	25	35	52	100	108	40	50	10	38.3	20.45	1.8
KASGH0400253	2	-DIN6	25	35	55	100	108	40	75	10	38.3	20.45	2.7
KASGH0400254	2	-DIN6	25	40	62	100	108	40	75	12	43.3	20.45	2.7
KASGH0400255	1	-DIN6	25	45	65	100	108	40	50	14	48.8	20.45	1.8
KASGH0400256	2	-DIN6	25	55	80	100	108	40	80	16	59.3	20.45	2.9
KASGH0400281	1	-DIN6	28	35	52	112	120	40	50	10	38.3	22.90	2.2
KASGH0400282	1	-DIN6	28	45	65	112	120	40	50	14	48.8	22.90	2.2
KASGH0400283	2	-DIN6	28	45	68	112	120	40	75	14	48.8	22.90	3.3
KASGH0400321	1	-DIN6	32	35	52	128	136	40	50	10	38.3	26.18	2.9
KASGH0400322	1	-DIN6	32	45	65	128	136	40	50	14	48.8	26.18	2.9
KASGH0400323	2	-DIN6	32	55	80	128	136	40	80	16	59.3	26.18	4.6
KASGH0400324	2	-DIN6	32	75	110	128	136	40	100	20	79.9	26.18	5.7
KASGH0400401	1	-DIN6	40	45	65	160	168	40	50	14	48.8	32.72	4.4
KASGH0400402	1	-DIN6	40	60	80	160	168	40	50	18	64.4	32.72	4.4
KASGH0400403	2	-DIN6	40	75	110	160	168	40	100	20	79.9	32.72	8.7
Module 5													
KASGH0500211	2	-DIN6	21	45	68	105	115	50	85	14	48.8	23.59	3.5
KASGH0500212	2	-DIN6	21	55	80	105	115	50	90	16	59.3	23.59	3.7
KASGH0500251	2	-DIN6	25	45	68	125	135	50	85	14	48.8	31.95	4.8
KASGH0500252	2	-DIN6	25	55	80	125	135	50	90	16	59.3	31.95	5.1
KASGH0500253	2	-DIN6	25	75	110	125	135	50	110	20	79.9	31.95	6.2
Module 6													
KASGH0600211	2	-DIN6	21	55	80	126	138	60	100	16	59.3	33.97	5.9
KASGH0600212	2	-DIN6	21	75	110	126	138	60	120	20	79.9	33.97	7.0
KASGH0600251	2	-DIN6	25	55	80	150	162	60	100	16	59.3	46.01	8.1
KASGH0600252	2	-DIN6	25	75	110	150	162	60	120	20	79.9	46.01	9.7
Module 8													
KASGH0800201	2	-DIN6	20	75	110	160	176	80	140	20	79.9	57.51	13.4
KASGH0800202	2	-DIN6	20	85	125	160	176	80	145	22	90.4	57.51	13.8



KASSH-DIN7

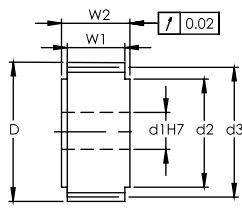

Fig. 1

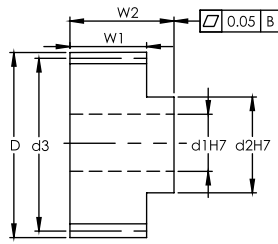
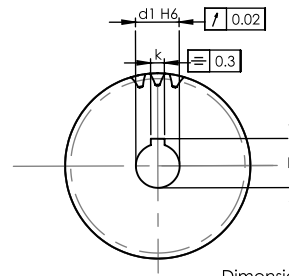

Fig. 2



Dimension: mm

- NOTE:
- 1) ALL THE SURFACES IN ALL THE VIEWS ARE TRUE.
 - 2) ALL THE SURFACES HAVE Rg 0.8 SURFACE FINISH.
 - 3) ALL THE SURFACES ARE GROUND.

Series KASSH-DIN7 Straight Skiving Pinions
Quality Grade DIN 7

Material SCM415/SCM440
Hardness: HRC 50~55°
Skiving after Hardening

Straight
DIN

Code	Fig.	DIN	No. of Teeth	d1	d2	d3	D	W1	W2	k	h	F _{ta} kN	KG
Module 2													
KASSH0200161	1	-DIN7	16	15	25	32	36	28	30	5	17.3	2.72	0.2
KASSH0200181	1	-DIN7	18	15	30	36	40	28	30	5	17.3	3.31	0.2
KASSH0200182	1	-DIN7	18	20	25	36	40	28	30	6	22.8	3.31	0.2
KASSH0200201	1	-DIN7	20	15	25	40	44	28	30	6	17.8	3.68	0.3
KASSH0200202	1	-DIN7	20	19	30	40	44	28	30	6	21.8	3.68	0.3
KASSH0200203	2	-DIN7	20	19	30	40	44	28	56	6	21.8	3.68	0.5
KASSH0200204	1	-DIN7	20	20	30	40	44	28	30	6	22.8	3.68	0.3
KASSH0200205	1	-DIN7	20	22	30	40	44	28	30	6	24.8	3.68	0.3
KASSH0200206	2	-DIN7	20	22	36	40	44	28	56	6	24.8	3.68	0.5
KASSH0200221	1	-DIN7	22	15	25	44	48	28	30	5	17.3	4.04	0.3
KASSH0200222	1	-DIN7	22	19	30	44	48	28	30	6	21.8	4.04	0.3
KASSH0200223	2	-DIN7	22	19	30	44	48	28	56	6	21.8	4.04	0.6
KASSH0200224	1	-DIN7	22	20	30	44	48	28	30	6	22.8	4.04	0.3
KASSH0200225	2	-DIN7	22	22	36	44	48	28	56	6	24.8	4.04	0.6
KASSH0200226	1	-DIN7	22	22	30	44	48	28	30	6	24.8	4.04	0.3
KASSH0200227	1	-DIN7	22	25	36	44	48	28	30	8	28.3	4.04	0.3
KASSH0200251	2	-DIN7	25	16	30	50	54	28	54	5	18.3	5.15	0.7
KASSH0200252	1	-DIN7	25	19	30	50	54	28	30	6	21.8	5.15	0.4
KASSH0200253	2	-DIN7	25	19	30	50	54	28	56	6	21.8	5.15	0.8
KASSH0200254	1	-DIN7	25	20	30	50	54	28	30	6	22.8	5.15	0.4
KASSH0200255	1	-DIN7	25	22	30	50	54	28	30	6	24.8	5.15	0.4
KASSH0200256	2	-DIN7	25	22	36	50	54	28	56	6	24.8	5.15	0.8
KASSH0200257	1	-DIN7	25	25	36	50	54	28	30	8	28.3	5.15	0.4
KASSH0200258	1	-DIN7	25	30	45	50	54	28	30	8	33.3	5.15	0.4
KASSH0200281	1	-DIN7	28	19	30	56	60	28	30	6	21.8	5.77	0.5
KASSH0200282	2	-DIN7	28	19	30	56	60	28	56	6	21.8	5.77	0.9
KASSH0200283	1	-DIN7	28	20	30	56	60	28	30	6	22.8	5.77	0.5
KASSH0200284	1	-DIN7	28	22	30	56	60	28	30	6	24.8	5.77	0.5
KASSH0200285	2	-DIN7	28	22	36	56	60	28	56	6	24.8	5.77	0.9
KASSH0200286	1	-DIN7	28	25	36	56	60	28	30	8	28.3	5.77	0.5
KASSH0200287	1	-DIN7	28	30	45	56	60	28	30	8	33.3	5.77	0.5
KASSH0200288	2	-DIN7	28	30	50	56	60	28	60	8	33.3	5.77	1.0
KASSH0200289	1	-DIN7	28	35	48	56	60	28	30	10	38.3	5.77	0.5
KASSH0200321	2	-DIN7	32	16	30	64	68	28	54	5	18.3	6.59	1.2
KASSH0200322	1	-DIN7	32	20	30	64	68	28	30	6	22.8	6.59	0.6
KASSH0200323	1	-DIN7	32	22	30	64	68	28	30	6	24.8	6.59	0.6
KASSH0200324	2	-DIN7	32	22	36	64	68	28	56	6	24.8	6.59	1.2
KASSH0200325	1	-DIN7	32	25	36	64	68	28	30	8	28.3	6.59	0.6
KASSH0200326	1	-DIN7	32	30	45	64	68	28	30	8	33.3	6.59	0.6
KASSH0200327	2	-DIN7	32	30	50	64	68	28	60	8	33.3	6.59	1.3
KASSH0200328	2	-DIN7	32	32	55	64	68	28	65	10	35.3	6.59	1.4
KASSH0200329	1	-DIN7	32	35	48	64	68	28	30	10	38.3	6.59	0.6
KASSH0200361	1	-DIN7	36	20	30	72	76	28	30	6	22.8	8.44	0.8

※Weight only for reference. Actual scale should be Weighing.



KASSH-DIN7

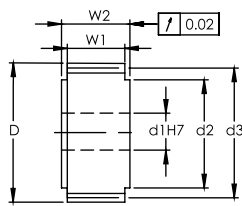

Fig. 1

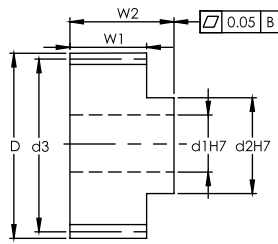
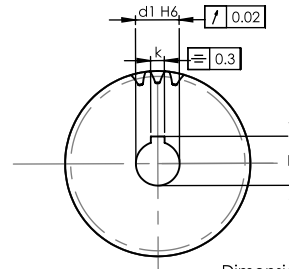

Fig. 2



Dimension: mm

NOTE:
 1) ALL THE SURFACES IN ALL THE VIEWS ARE TRUE.
 2) ALL THE SURFACES HAVE Rg 0.8 SURFACE FINISH.
 3) ALL THE SURFACES ARE GROUND.

Straight

DIN

Series KASSH-DIN7 Straight Skiving Pinions
 Quality Grade DIN 7

Material SCM415/SCM440
 Hardness: HRC 50~55°
 Skiving after Hardening

Code	Fig.	DIN	No. of Teeth	d1	d2	d3	D	W1	W2	k	h	F _{ta} kN	KG
Module 2													
KASSH0200362	1	-DIN7	36	25	36	72	76	28	30	8	28.3	8.44	0.8
KASSH0200363	1	-DIN7	36	30	45	72	76	28	30	8	33.3	8.44	0.8
KASSH0200364	1	-DIN7	36	35	48	72	76	28	30	10	38.3	8.44	0.8
KASSH0200365	2	-DIN7	36	40	62	72	76	28	65	12	43.3	8.44	1.7
KASSH0200366	1	-DIN7	36	45	58	72	76	28	30	14	48.8	8.44	0.8
KASSH0200401	1	-DIN7	40	15	36	80	84	28	30	5	17.3	9.38	1.0
KASSH0200402	1	-DIN7	40	20	30	80	84	28	30	6	22.8	9.38	1.0
KASSH0200403	1	-DIN7	40	25	36	80	84	28	30	8	28.3	9.38	1.0
KASSH0200404	1	-DIN7	40	30	45	80	84	28	30	8	33.3	9.38	1.0
KASSH0200405	2	-DIN7	40	32	55	80	84	28	65	10	35.3	9.38	2.1
KASSH0200406	1	-DIN7	40	35	48	80	84	28	30	10	38.3	9.38	1.0
KASSH0200407	2	-DIN7	40	40	62	80	84	28	65	12	43.3	9.38	2.1
KASSH0200408	1	-DIN7	40	45	58	80	84	28	30	14	48.8	9.38	1.0
KASSH0200409	2	-DIN7	40	45	68	80	84	28	65	14	48.8	9.38	2.1
KASSH0200451	1	-DIN7	45	20	30	90	94	28	30	6	22.8	10.55	1.2
KASSH0200452	1	-DIN7	45	25	36	90	94	28	30	8	28.3	10.55	1.2
KASSH0200453	1	-DIN7	45	35	48	90	94	28	30	10	38.3	10.55	1.2
KASSH0200454	1	-DIN7	45	45	58	90	94	28	30	14	48.8	10.55	1.2
KASSH0200501	1	-DIN7	50	20	30	100	104	28	30	6	22.8	10.96	1.5
KASSH0200502	1	-DIN7	50	25	36	100	104	28	30	8	28.3	10.96	1.5
KASSH0200503	1	-DIN7	50	35	48	100	104	28	30	10	38.3	10.96	1.5
KASSH0200504	1	-DIN7	50	45	58	100	104	28	30	14	48.8	10.96	1.5
KASSH0200505	2	-DIN7	50	45	68	100	104	28	65	14	48.8	10.96	3.3
KASSH0200561	1	-DIN7	56	25	36	112	116	28	30	8	28.3	11.15	1.9
KASSH0200562	1	-DIN7	56	35	48	112	116	28	30	10	38.3	11.15	1.9



KASSH-DIN7

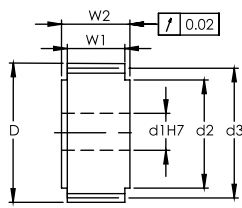

Fig. 1

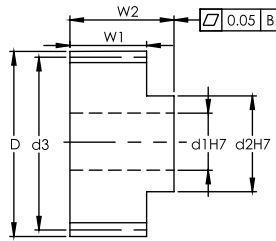
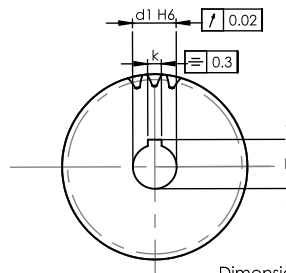

Fig. 2



Dimension: mm

- NOTE:
- 1) ALL THE SURFACES IN ALL THE VIEWS ARE TRUE.
 - 2) ALL THE SURFACES HAVE R_a 0.8 SURFACE FINISH.
 - 3) ALL THE SURFACES ARE GROUND.

Series KASSH-DIN7 Straight Skiving Pinions
Quality Grade DIN 7

Material SCM415/SCM440
Hardness: HRC 50~55°
Skiving after Hardening

Straight

DIN

Code	Fig.	DIN	No. of Teeth	d1	d2	d3	D	W1	W2	k	h	F _{ta} kN	KG
Module 3													
KASSH0300181	1	-DIN7	18	25	36	54	60	28	30	8	28.3	5.56	0.4
KASSH0300201	1	-DIN7	20	25	36	60	66	28	30	8	28.3	6.18	0.5
KASSH0300202	1	-DIN7	20	30	45	60	66	28	30	8	33.3	6.18	0.5
KASSH0300203	1	-DIN7	20	35	48	60	66	28	30	10	38.3	6.18	0.5
KASSH0300221	2	-DIN7	22	22	36	66	72	28	56	6	24.8	6.80	1.1
KASSH0300222	1	-DIN7	22	25	36	66	72	28	30	8	28.3	6.80	0.6
KASSH0300223	2	-DIN7	22	25	44	66	72	28	60	8	28.3	6.80	1.2
KASSH0300224	1	-DIN7	22	30	45	66	72	28	30	8	33.3	6.80	0.6
KASSH0300225	2	-DIN7	22	32	55	66	72	28	65	10	35.3	6.80	1.2
KASSH0300226	2	-DIN7	22	30	50	66	72	28	60	8	33.3	6.80	1.2
KASSH0300227	1	-DIN7	22	35	48	66	72	28	30	10	38.3	6.80	0.6
KASSH0300228	2	-DIN7	22	35	55	66	72	28	65	10	38.3	6.80	1.2
KASSH0300229	2	-DIN7	22	40	62	66	72	28	65	12	43.3	6.80	1.2
KASSH0300251	1	-DIN7	25	25	36	75	81	28	30	8	28.3	8.79	0.7
KASSH0300252	1	-DIN7	25	30	45	75	81	28	30	8	33.3	8.79	0.7
KASSH0300253	2	-DIN7	25	32	55	75	81	28	65	10	35.3	8.79	1.6
KASSH0300254	1	-DIN7	25	35	48	75	81	28	30	10	38.3	8.79	0.7
KASSH0300255	2	-DIN7	25	40	62	75	81	28	65	12	43.3	8.79	1.6
KASSH0300256	1	-DIN7	25	45	58	75	81	28	30	14	48.8	8.79	0.7
KASSH0300281	2	-DIN7	28	22	36	84	90	28	56	6	24.8	9.85	1.7
KASSH0300282	1	-DIN7	28	25	36	84	90	28	30	8	28.3	9.85	0.9
KASSH0300283	2	-DIN7	28	25	44	84	90	28	60	8	28.3	9.85	1.8
KASSH0300284	1	-DIN7	28	30	45	84	90	28	30	8	33.3	9.85	0.9
KASSH0300285	2	-DIN7	28	30	50	84	90	28	60	8	33.3	9.85	1.8
KASSH0300286	2	-DIN7	28	32	55	84	90	28	65	10	35.3	9.85	1.9
KASSH0300287	1	-DIN7	28	35	48	84	90	28	30	10	38.3	9.85	0.9
KASSH0300288	2	-DIN7	28	35	55	84	90	28	65	10	38.3	9.85	1.9
KASSH0300289	2	-DIN7	28	40	62	84	90	28	65	12	43.3	9.85	1.9
KASSH03002810	1	-DIN7	28	45	58	84	90	28	30	14	48.8	9.85	0.9
KASSH03002811	2	-DIN7	28	45	68	84	90	28	65	14	48.8	9.85	1.9
KASSH0300321	1	-DIN7	32	25	36	96	102	28	30	8	28.3	11.25	1.2
KASSH0300323	1	-DIN7	32	30	45	96	102	28	30	8	33.3	11.25	1.2
KASSH0300323	2	-DIN7	32	32	55	96	102	28	65	10	35.3	11.25	2.5
KASSH0300324	1	-DIN7	32	35	48	96	102	28	30	10	38.3	11.25	1.2
KASSH0300325	2	-DIN7	32	40	62	96	102	28	65	12	43.3	11.25	2.5
KASSH0300326	1	-DIN7	32	45	58	96	102	28	30	14	48.8	11.25	1.2
KASSH0300327	1	-DIN7	32	60	80	96	102	28	30	18	64.4	11.25	1.2
KASSH0300361	1	-DIN7	36	25	36	108	114	28	30	8	28.3	12.66	1.4
KASSH0300362	1	-DIN7	36	35	48	108	114	28	30	10	38.3	12.66	1.4
KASSH0300363	1	-DIN7	36	45	58	108	114	28	30	14	48.8	12.66	1.4
KASSH0300364	2	-DIN7	36	45	68	108	114	28	65	14	48.8	12.66	3.1
KASSH0300365	1	-DIN7	36	60	80	108	114	28	30	18	64.4	12.66	1.4
KASSH0300401	1	-DIN7	40	25	36	120	126	28	30	8	28.3	14.07	1.8



KASSH-DIN7

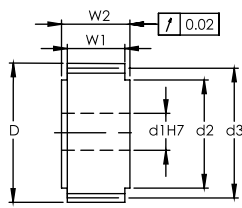

Fig. 1

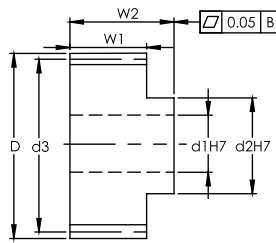
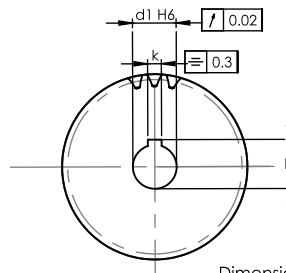

Fig. 2



Dimension: mm

- NOTE:
- 1) ALL THE SURFACES IN ALL THE VIEWS ARE TRUE.
 - 2) ALL THE SURFACES HAVE R_a 0.8 SURFACE FINISH.
 - 3) ALL THE SURFACES ARE GROUND.

Straight

DIN

Series KASSH-DIN7 Straight Skiving Pinions
Quality Grade DIN 7

Material SCM415/SCM440
Hardness: HRC 50~55°
Skiving after Hardening

Code	Fig.	DIN	No. of Teeth	d1	d2	d3	D	W1	W2	k	h	F _{ta} kN	KG
Module 3													
KASSH0300402	1	-DIN7	40	35	48	120	126	28	30	10	38.3	14.07	1.8
KASSH0300403	1	-DIN7	40	45	58	120	126	28	30	14	48.8	14.07	1.8
KASSH0300404	1	-DIN7	40	60	80	120	126	28	30	18	64.4	14.07	1.8
KASSH0300451	1	-DIN7	45	25	36	135	141	28	30	8	28.3	15.83	2.2
KASSH0300452	1	-DIN7	45	35	48	135	141	28	30	10	38.3	15.83	2.2
KASSH0300453	1	-DIN7	45	45	58	135	141	28	30	14	48.8	15.83	2.2
KASSH0300454	1	-DIN7	45	60	80	135	141	28	30	18	64.4	15.83	2.2
KASSH0300501	1	-DIN7	50	35	48	150	156	28	30	10	38.3	16.45	2.7
KASSH0300502	1	-DIN7	50	45	58	150	156	28	30	14	48.8	16.45	2.7
KASSH0300561	1	-DIN7	56	45	58	168	174	28	30	14	48.8	16.73	3.4
KASSH0300631	1	-DIN7	63	45	58	189	195	28	30	14	48.8	17.02	4.2
KASSH0300632	1	-DIN7	63	60	80	189	195	28	30	18	64.4	17.02	4.2



KASSH-DIN7

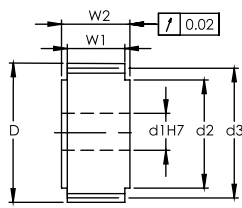

Fig. 1

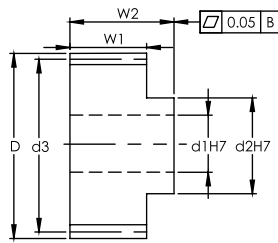
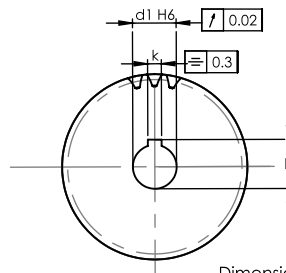

Fig. 2



Dimension: mm

NOTE:
 1) ALL THE SURFACES IN ALL THE VIEWS ARE TRUE.
 2) ALL THE SURFACES HAVE Rg 0.8 SURFACE FINISH.
 3) ALL THE SURFACES ARE GROUND.

Series KASSH-DIN7 Straight Skiving Pinions
 Quality Grade DIN 7

Material SCM415/SCM440
 Hardness: HRC 50~55°
 Skiving after Hardening



Code	Fig.	DIN	No. of Teeth	d1	d2	d3	D	W1	W2	k	h	F _{ta} kN	KG
Module 4													
KASSH0400201	2	-DIN7	20	32	55	80	88	40	75	10	35.3	11.77	1.8
KASSH0400202	1	-DIN7	20	35	52	80	88	40	50	10	38.3	11.77	1.2
KASSH0400203	2	-DIN7	20	35	55	80	88	40	75	10	38.3	11.77	1.8
KASSH0400204	1	-DIN7	20	45	65	80	88	40	50	14	48.8	11.77	1.2
KASSH0400205	2	-DIN7	20	40	62	80	88	40	75	12	43.3	11.77	1.8
KASSH0400221	1	-DIN7	22	35	52	88	96	40	50	10	38.3	12.95	1.4
KASSH0400222	1	-DIN7	22	45	65	88	96	40	50	14	48.8	12.95	1.4
KASSH0400223	2	-DIN7	22	45	68	88	96	40	75	14	48.8	12.95	2.1
KASSH0400251	2	-DIN7	25	32	55	100	108	40	75	10	35.3	16.75	2.7
KASSH0400252	1	-DIN7	25	35	52	100	108	40	50	10	38.3	16.75	1.8
KASSH0400253	2	-DIN7	25	35	55	100	108	40	75	10	38.3	16.75	2.7
KASSH0400254	2	-DIN7	25	40	62	100	108	40	75	12	43.3	16.75	2.7
KASSH0400255	1	-DIN7	25	45	65	100	108	40	50	14	48.8	16.75	1.8
KASSH0400256	2	-DIN7	25	55	80	100	108	40	80	16	59.3	16.75	2.9
KASSH0400281	1	-DIN7	28	35	52	112	120	40	50	10	38.3	18.76	2.2
KASSH0400282	1	-DIN7	28	45	65	112	120	40	50	14	48.8	18.76	2.2
KASSH0400283	2	-DIN7	28	45	68	112	120	40	75	14	48.8	18.76	3.3
KASSH0400321	1	-DIN7	32	35	52	128	136	40	50	10	38.3	21.44	2.9
KASSH0400322	1	-DIN7	32	45	65	128	136	40	50	14	48.8	21.44	2.9
KASSH0400323	2	-DIN7	32	55	80	128	136	40	80	16	59.3	21.44	4.6
KASSH0400324	2	-DIN7	32	75	110	128	136	40	100	20	79.9	21.44	5.7
KASSH0400401	1	-DIN7	40	45	65	160	168	40	50	14	48.8	26.80	4.4
KASSH0400402	1	-DIN7	40	60	80	160	168	40	50	18	64.4	26.80	4.4
KASSH0400403	2	-DIN7	40	75	110	160	168	40	100	20	79.9	26.80	8.7
Module 5													
KASSH0500211	2	-DIN7	21	45	68	105	115	50	85	14	48.8	19.32	3.5
KASSH0500212	2	-DIN7	21	55	80	105	115	50	90	16	59.3	19.32	3.7
KASSH0500251	2	-DIN7	25	45	68	125	135	50	85	14	48.8	26.17	4.8
KASSH0500252	2	-DIN7	25	55	80	125	135	50	90	16	59.3	26.17	5.1
KASSH0500253	2	-DIN7	25	75	110	125	135	50	110	20	79.9	26.17	6.2
Module 6													
KASSH0600211	2	-DIN7	21	55	80	126	138	60	100	16	59.3	27.82	5.9
KASSH0600212	2	-DIN7	21	75	110	126	138	60	120	20	79.9	27.82	7.0
KASSH0600251	2	-DIN7	25	55	80	150	162	60	100	16	59.3	37.68	8.1
KASSH0600252	2	-DIN7	25	75	110	150	162	60	120	20	79.9	37.68	9.7
Module 8													
KASSH0800201	2	-DIN7	20	75	110	160	176	80	140	20	79.9	47.09	13.4
KASSH0800202	2	-DIN7	20	85	125	160	176	80	145	22	90.4	47.09	13.8



KCSM-DIN8

Straight
DIN

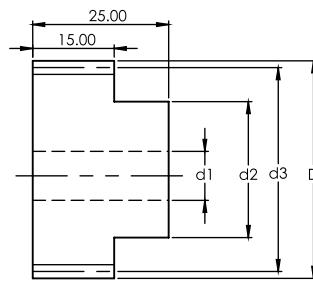

Fig. 1

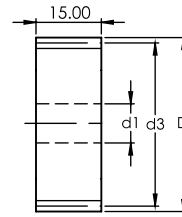

Fig.2 Dimension: mm

NOTE:
1) ALL THE SURFACES HAVE Ra1.6 SURFACE FINISH.

Series KCSM-DIN8 Straight Soft Pinions
Quality Grade DIN 8

Material S45C / S50C

Code	Fig.	DIN	No. of Teeth	d1	d2	d3	D	W1	W2	k	h	F _{ta} kN	KG
Module 1													
KCSM0100121	1	-DIN8	12	6	9	12.0	14.0	*	*	*	*	*	0.1
KCSM0100131	1	-DIN8	13	6	9	13.0	15.0	*	*	*	*	*	0.1
KCSM0100141	1	-DIN8	14	6	11	14.0	16.0	*	*	*	*	*	0.1
KCSM0100151	1	-DIN8	15	6	12	15.0	17.0	*	*	*	*	*	0.1
KCSM0100161	1	-DIN8	16	6	12	16.0	18.0	*	*	*	*	0.10	0.1
KCSM0100171	1	-DIN8	17	6	14	17.0	19.0	*	*	*	*	0.11	0.1
KCSM0100181	1	-DIN8	18	6	15	18.0	20.0	*	*	*	*	0.12	0.1
KCSM0100191	1	-DIN8	19	6	15	19.0	21.0	*	*	*	*	0.13	0.1
KCSM0100201	1	-DIN8	20	6	16	20.0	22.0	*	*	*	*	0.14	0.1
KCSM0100211	1	-DIN8	21	6	16	21.0	23.0	*	*	*	*	0.15	0.1
KCSM0100221	1	-DIN8	22	6	18	22.0	24.0	*	*	*	*	0.15	0.1
KCSM0100231	1	-DIN8	23	6	18	23.0	25.0	*	*	*	*	0.16	0.1
KCSM0100241	1	-DIN8	24	9	20	24.0	26.0	*	*	*	*	0.17	0.1
KCSM0100251	1	-DIN8	25	9	20	25.0	27.0	*	*	*	*	0.19	0.1
KCSM0100301	1	-DIN8	30	9	20	30.0	32.0	*	*	*	*	0.23	0.1
KCSM0100351	1	-DIN8	35	9	25	35.0	37.0	*	*	*	*	0.27	0.2
KCSM0100381	1	-DIN8	38	9	25	38.0	40.0	*	*	*	*	0.33	0.2
KCSM0100401	1	-DIN8	40	9	25	40.0	42.0	*	*	*	*	0.35	0.2
KCSM0100451	1	-DIN8	45	9	30	45.0	47.0	*	*	*	*	0.40	0.3
KCSM0100481	1	-DIN8	48	9	30	48.0	50.0	*	*	*	*	0.42	0.3
KCSM0100501	1	-DIN8	50	9	30	50.0	52.0	*	*	*	*	0.44	0.3
KCSM0100571	1	-DIN8	57	9	40	57.0	59.0	*	*	*	*	0.50	0.4
KCSM0100601	1	-DIN8	60	9	40	60.0	62.0	*	*	*	*	0.53	0.4
KCSM0100761	2	-DIN8	76	10	*	76.0	78.0	*	*	*	*	0.81	0.7
KCSM0100801	2	-DIN8	80	10	*	80.0	82.0	*	*	*	*	0.85	0.8
KCSM0100951	2	-DIN8	95	10	*	95.0	97.0	*	*	*	*	1.01	1.1
KCSM0101001	2	-DIN8	100	10	*	100.0	102.0	*	*	*	*	1.06	1.2
KCSM0101141	2	-DIN8	114	10	*	114.0	116.0	*	*	*	*	1.16	1.6



KCSM-DIN8

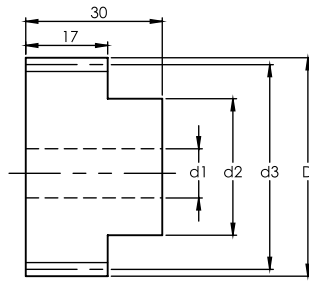

Fig. 1

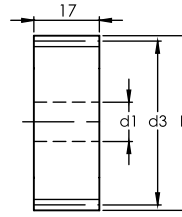

Fig. 2 Dimension: mm

NOTE:
1) ALL THE SURFACES HAVE Ra1.6 SURFACE FINISH.

Series KCSM-DIN8 Straight Soft Pinions
Quality Grade DIN 8

Material S45C / S50C

Straight

DIN

Code	Fig.	DIN	No. of Teeth	d1	d2	d3	D	W1	W2	k	h	F _{ta} kN	KG
Module 1.5													
KCSM0150121	1	-DIN8	12	6	14	18.0	21.0	*	*	*	*	*	0.1
KCSM0150131	1	-DIN8	13	6	14	19.5	22.5	*	*	*	*	*	0.1
KCSM0150141	1	-DIN8	14	6	16	21.0	24.0	*	*	*	*	*	0.1
KCSM0150151	1	-DIN8	15	6	18	22.5	25.5	*	*	*	*	*	0.1
KCSM0150161	1	-DIN8	16	6	18	24.0	27.0	*	*	*	*	0.19	0.1
KCSM0150171	1	-DIN8	17	9	20	25.5	28.5	*	*	*	*	0.20	0.1
KCSM0150181	1	-DIN8	18	9	20	27.0	30.0	*	*	*	*	0.21	0.1
KCSM0150191	1	-DIN8	19	9	20	28.5	31.5	*	*	*	*	0.25	0.1
KCSM0150201	1	-DIN8	20	9	25	30.0	33.0	*	*	*	*	0.26	0.2
KCSM0150211	1	-DIN8	21	9	25	31.5	34.5	*	*	*	*	0.28	0.2
KCSM0150221	1	-DIN8	22	9	25	33.0	36.0	*	*	*	*	0.29	0.2
KCSM0150222	1	-DIN8	22	8	28	33.0	36.0	*	*	*	*	0.29	0.2
KCSM0150231	1	-DIN8	23	9	25	34.5	37.5	*	*	*	*	0.30	0.2
KCSM0150241	1	-DIN8	24	9	25	36.0	39.0	*	*	*	*	0.32	0.2
KCSM0150251	1	-DIN8	25	9	25	37.5	40.5	*	*	*	*	0.33	0.2
KCSM0150301	1	-DIN8	30	9	25	45.0	48.0	*	*	*	*	0.45	0.3
KCSM0150351	1	-DIN8	35	9	40	52.5	55.5	*	*	*	*	0.52	0.4
KCSM0150381	1	-DIN8	38	9	40	57.0	60.0	*	*	*	*	0.57	0.5
KCSM0150401	1	-DIN8	40	9	40	60.0	63.0	*	*	*	*	0.60	0.6
KCSM0150451	1	-DIN8	45	12	50	67.5	70.5	*	*	*	*	0.67	0.7
KCSM0150481	1	-DIN8	48	12	50	72.0	75.0	*	*	*	*	0.72	0.8
KCSM0150501	1	-DIN8	50	12	50	75.0	78.0	*	*	*	*	0.75	0.8
KCSM0150571	1	-DIN8	57	12	60	85.5	88.5	*	*	*	*	1.03	1.1
KCSM0150601	1	-DIN8	60	12	60	90.0	93.0	*	*	*	*	1.08	1.2
KCSM0150761	2	-DIN8	76	16	*	114.0	117.0	*	*	*	*	1.37	1.9
KCSM0150801	2	-DIN8	80	16	*	120.0	123.0	*	*	*	*	1.45	2.1
KCSM0150951	2	-DIN8	95	20	*	142.5	145.5	*	*	*	*	1.72	2.9



KCSM-DIN8

Straight
DIN

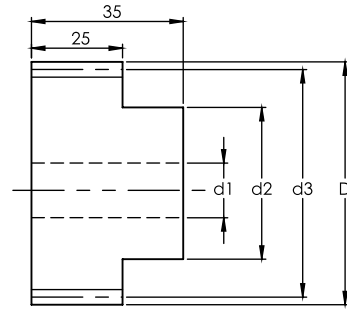

Fig. 1

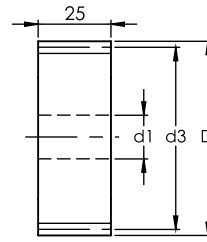

Fig. 2
Dimension: mm

NOTE:
1) ALL THE SURFACES HAVE Ra1.6 SURFACE FINISH.

Series KCSM-DIN8 Straight Soft Pinions
Quality Grade DIN 8

Material S45C / S50C

Code	Fig.	DIN	No. of Teeth	d1	d2	d3	D	W1	W2	k	h	F _{ta} kN	KG
Module 2													
KCSM0200121	1	-DIN8	12	9	18	24.0	28.0	*	*	*	*	*	0.1
KCSM0200131	1	-DIN8	13	9	19	26.0	30.0	*	*	*	*	*	0.1
KCSM0200141	1	-DIN8	14	9	19	28.0	32.0	*	*	*	*	*	0.2
KCSM0200151	1	-DIN8	15	9	24.5	30.0	34.0	*	*	*	*	*	0.2
KCSM0200161	1	-DIN8	16	9	25	32.0	36.0	*	*	*	*	0.37	0.2
KCSM0200171	1	-DIN8	17	9	25	34.0	38.0	*	*	*	*	0.39	0.2
KCSM0200181	1	-DIN8	18	9	25	36.0	40.0	*	*	*	*	0.41	0.3
KCSM0200191	1	-DIN8	19	9	25	38.0	42.0	*	*	*	*	0.44	0.3
KCSM0200201	1	-DIN8	20	9	30	40.0	44.0	*	*	*	*	0.46	0.3
KCSM0200211	1	-DIN8	21	9	30	42.0	46.0	*	*	*	*	0.54	0.3
KCSM0200221	1	-DIN8	22	9	30	44.0	48.0	*	*	*	*	0.57	0.4
KCSM0200231	1	-DIN8	23	9	30	46.0	50.0	*	*	*	*	0.59	0.4
KCSM0200241	1	-DIN8	24	12	35	48.0	52.0	*	*	*	*	0.62	0.4
KCSM0200251	1	-DIN8	25	12	35	50.0	54.0	*	*	*	*	0.64	0.5
KCSM0200281	1	-DIN8	28	12	40	56.0	60.0	*	*	*	*	0.72	0.6
KCSM0200301	1	-DIN8	30	12	40	60.0	64.0	*	*	*	*	0.77	0.7
KCSM0200321	1	-DIN8	32	12	40	64.0	68.0	*	*	*	*	0.94	0.7
KCSM0200351	1	-DIN8	35	12	50	70.0	74.0	*	*	*	*	1.03	0.9
KCSM0200361	1	-DIN8	36	12	50	72.0	76.0	*	*	*	*	1.06	0.9
KCSM0200381	1	-DIN8	38	12	50	76.0	80.0	*	*	*	*	1.11	1.0
KCSM0200401	1	-DIN8	40	12	50	80.0	84.0	*	*	*	*	1.17	1.1
KCSM0200451	1	-DIN8	45	12	60	90.0	94.0	*	*	*	*	1.32	1.4
KCSM0200481	1	-DIN8	48	15	70	96.0	100.0	*	*	*	*	1.41	1.6
KCSM0200501	1	-DIN8	50	15	70	100.0	104.0	*	*	*	*	1.47	1.8
KCSM0200561	1	-DIN8	56	15	70	112.0	116.0	*	*	*	*	1.64	2.2
KCSM0200571	1	-DIN8	57	15	70	114.0	118.0	*	*	*	*	1.67	2.3
KCSM0200601	1	-DIN8	60	15	70	120.0	124.0	*	*	*	*	1.76	2.5
KCSM0200761	2	-DIN8	76	20	*	152.0	156.0	*	*	*	*	2.69	3.9
KCSM0200801	2	-DIN8	80	20	*	160.0	164.0	*	*	*	*	2.84	4.4
KCSM0200951	2	-DIN8	95	20	*	190.0	194.0	*	*	*	*	3.37	6.1



KCSM-DIN8

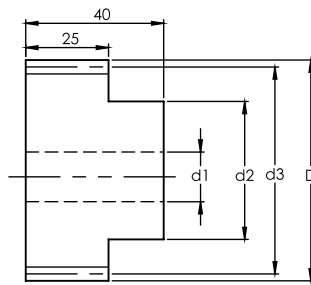

Fig. 1

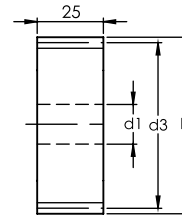

Fig. 2 Dimension: mm

NOTE:
1) ALL THE SURFACES HAVE Ra1.6 SURFACE FINISH.

Series KCSM-DIN8 Straight Soft Pinions
Quality Grade DIN 8

Material S45C / S50C

Straight
DIN

Code	Fig.	DIN	No. of Teeth	d1	d2	d3	D	W1	W2	k	h	F _{ta} kN	KG
Module 2.5													
KCSM0250121	1	-DIN8	12	9	20	30.0	35.0	*	*	*	*	*	0.2
KCSM0250131	1	-DIN8	13	9	20	32.5	37.5	*	*	*	*	*	0.3
KCSM0250141	1	-DIN8	14	9	25	35.0	40.0	*	*	*	*	*	0.3
KCSM0250151	1	-DIN8	15	9	25	37.5	42.5	*	*	*	*	*	0.3
KCSM0250161	1	-DIN8	16	9	30	40.0	45.0	*	*	*	*	0.46	0.4
KCSM0250171	1	-DIN8	17	9	30	42.5	47.5	*	*	*	*	0.55	0.4
KCSM0250181	1	-DIN8	18	9	35	45.0	50.0	*	*	*	*	0.58	0.5
KCSM0250191	1	-DIN8	19	12	35	47.5	52.5	*	*	*	*	0.61	0.5
KCSM0250201	1	-DIN8	20	12	35	50.0	55.0	*	*	*	*	0.64	0.6
KCSM0250211	1	-DIN8	21	12	35	52.5	57.5	*	*	*	*	0.68	0.6
KCSM0250221	1	-DIN8	22	12	40	55.0	60.0	*	*	*	*	0.71	0.7
KCSM0250231	1	-DIN8	23	12	40	57.5	62.5	*	*	*	*	0.74	0.7
KCSM0250241	1	-DIN8	24	12	40	60.0	65.0	*	*	*	*	0.77	0.8
KCSM0250251	1	-DIN8	25	12	45	62.5	67.5	*	*	*	*	0.92	0.8
KCSM0250301	1	-DIN8	30	12	50	75.0	80.0	*	*	*	*	1.10	1.2
KCSM0250351	1	-DIN8	35	12	60	87.5	92.5	*	*	*	*	1.28	1.6
KCSM0250381	1	-DIN8	38	12	60	95.0	100.0	*	*	*	*	1.39	1.8
KCSM0250401	1	-DIN8	40	12	70	100.0	105.0	*	*	*	*	1.47	2.0
KCSM0250451	1	-DIN8	45	15	70	112.5	117.5	*	*	*	*	1.65	2.6
KCSM0250481	1	-DIN8	48	15	80	120.0	125.0	*	*	*	*	1.76	2.9
KCSM0250501	1	-DIN8	50	15	80	125.0	130.0	*	*	*	*	2.22	3.1
KCSM0250571	1	-DIN8	57	15	90	142.5	147.5	*	*	*	*	2.53	4.0
KCSM0250601	1	-DIN8	60	15	90	150.0	155.0	*	*	*	*	2.66	4.4
KCSM0250761	1	-DIN8	76	20	*	190.0	195.0	*	*	*	*	3.37	7.0
KCSM0250801	1	-DIN8	80	25	*	200.0	205.0	*	*	*	*	3.54	7.8
KCSM0250951	1	-DIN8	95	25	*	237.5	242.5	*	*	*	*	4.21	10.9



KCSM-DIN8

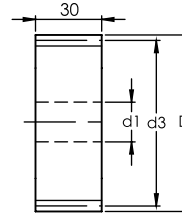
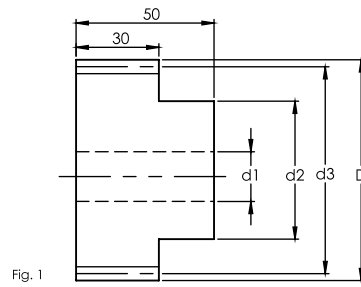

Dimension: mm

NOTE:
1) ALL THE SURFACES HAVE Ra1.6 SURFACE FINISH.

Series KCSM-DIN8 Straight Soft Pinions
Quality Grade DIN 8

Material S45C / S50C

Straight

DIN

Code	Fig.	DIN	No. of Teeth	d1	d2	d3	D	W1	W2	k	h	F _{ta} kN	KG
Module 3													
KCSM0300121	1	-DIN8	12	14	25	36	42	*	*	*	*	*	0.3
KCSM0300131	1	-DIN8	13	14	25	39	45	*	*	*	*	*	0.4
KCSM0300141	1	-DIN8	14	14	25	42	48	*	*	*	*	*	0.4
KCSM0300151	1	-DIN8	15	14	35	45	51	*	*	*	*	*	0.5
KCSM0300161	1	-DIN8	16	14	35	48	54	*	*	*	*	0.66	0.5
KCSM0300171	1	-DIN8	17	14	42	51	57	*	*	*	*	0.79	0.6
KCSM0300181	1	-DIN8	18	14	45	54	60	*	*	*	*	0.84	0.7
KCSM0300191	1	-DIN8	19	14	45	57	63	*	*	*	*	0.88	0.7
KCSM0300201	1	-DIN8	20	14	45	60	66	*	*	*	*	0.93	0.8
KCSM0300211	1	-DIN8	21	14	45	63	69	*	*	*	*	0.97	0.9
KCSM0300221	1	-DIN8	22	14	50	66	72	*	*	*	*	1.02	1.0
KCSM0300231	1	-DIN8	23	14	50	69	75	*	*	*	*	1.07	1.0
KCSM0300241	1	-DIN8	24	14	50	72	78	*	*	*	*	1.11	1.1
KCSM0300251	1	-DIN8	25	14	60	75	81	*	*	*	*	1.32	1.2
KCSM0300271	1	-DIN8	27	14	60	81	87	*	*	*	*	1.43	1.4
KCSM0300281	1	-DIN8	28	14	60	84	90	*	*	*	*	1.48	1.5
KCSM0300282	1	-DIN8	28	15	60	84	90	*	*	*	*	1.48	1.5
KCSM0300301	1	-DIN8	30	14	60	90	96	*	*	*	*	1.58	1.7
KCSM0300321	1	-DIN8	32	14	60	96	102	*	*	*	*	1.69	1.9
KCSM0300351	1	-DIN8	35	14	80	105	111	*	*	*	*	1.85	2.3
KCSM0300361	1	-DIN8	36	14	80	108	114	*	*	*	*	1.90	2.4
KCSM0300381	1	-DIN8	38	14	80	114	120	*	*	*	*	2.01	2.7
KCSM0300401	1	-DIN8	40	14	80	120	126	*	*	*	*	2.11	2.9
KCSM0300451	2	-DIN8	45	20	*	135	141	*	*	*	*	2.38	3.7
KCSM0300481	2	-DIN8	48	20	*	144	150	*	*	*	*	2.53	4.2
KCSM0300501	2	-DIN8	50	25	*	150	156	*	*	*	*	3.19	4.5
KCSM0300521	2	-DIN8	52	25	*	156	162	*	*	*	*	3.32	5.0
KCSM0300561	2	-DIN8	56	25	*	168	174	*	*	*	*	3.57	5.6
KCSM0300601	2	-DIN8	60	25	*	180	186	*	*	*	*	3.83	6.4
KCSM0300761	2	-DIN8	76	25	*	228	234	*	*	*	*	4.85	10.1
KCSM0300801	2	-DIN8	80	25	*	240	246	*	*	*	*	5.10	11.2
KCSM0300951	2	-DIN8	95	25	*	285	291	*	*	*	*	6.06	15.7



KCSM-DIN8

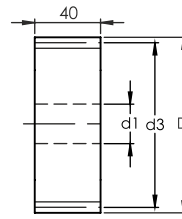
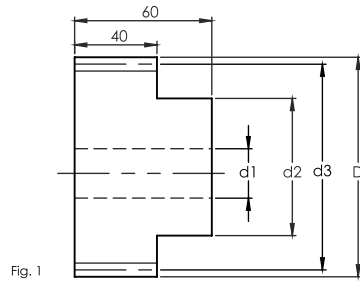

Dimension: mm

NOTE:
1) ALL THE SURFACES HAVE Ra1.6 SURFACE FINISH.

Series KCSM-DIN8 Straight Soft Pinions
Quality Grade DIN 8

Material S45C / S50C

Straight

DIN

Code	Fig.	DIN	No. of Teeth	d1	d2	d3	D	W1	W2	k	h	F _{ta} kN	KG
Module 4													
KCSM0400121	1	-DIN8	12	16	35	48	56	*	*	*	*	*	0.6
KCSM0400131	1	-DIN8	13	16	35	52	60	*	*	*	*	*	0.7
KCSM0400141	1	-DIN8	14	16	45	56	64	*	*	*	*	*	0.8
KCSM0400151	1	-DIN8	15	16	45	60	68	*	*	*	*	*	0.9
KCSM0400161	1	-DIN8	16	16	45	64	72	*	*	*	*	1.18	1.0
KCSM0400171	1	-DIN8	17	16	50	68	76	*	*	*	*	1.40	1.1
KCSM0400181	1	-DIN8	18	16	50	72	80	*	*	*	*	1.49	1.2
KCSM0400191	1	-DIN8	19	16	60	76	84	*	*	*	*	1.57	1.3
KCSM0400201	1	-DIN8	20	16	60	80	88	*	*	*	*	1.65	1.4
KCSM0400211	1	-DIN8	21	16	70	84	92	*	*	*	*	1.73	1.6
KCSM0400221	1	-DIN8	22	16	70	88	96	*	*	*	*	1.81	1.7
KCSM0400231	1	-DIN8	23	16	75	92	100	*	*	*	*	1.90	1.8
KCSM0400241	1	-DIN8	24	16	75	96	104	*	*	*	*	1.98	2.0
KCSM0400251	1	-DIN8	25	16	75	100	108	*	*	*	*	2.35	2.2
KCSM0400301	1	-DIN8	30	16	75	120	128	*	*	*	*	2.82	3.0
KCSM0400381	2	-DIN8	38	25	*	152	160	*	*	*	*	3.57	4.7
KCSM0400401	2	-DIN8	40	25	*	160	168	*	*	*	*	3.75	5.2
KCSM0400451	2	-DIN8	45	25	*	180	188	*	*	*	*	4.22	6.5
KCSM0400481	2	-DIN8	48	25	*	192	200	*	*	*	*	4.51	7.4
KCSM0400501	2	-DIN8	50	25	*	200	208	*	*	*	*	5.67	8.0
KCSM0400521	2	-DIN8	52	25	*	208	216	*	*	*	*	5.90	8.6
KCSM0400561	2	-DIN8	56	25	*	224	232	*	*	*	*	6.35	10.0
KCSM0400601	2	-DIN8	60	25	*	240	248	*	*	*	*	6.80	11.4
KCSM0400761	2	-DIN8	76	25	*	304	312	*	*	*	*	8.62	18.0
KCSM0400801	2	-DIN8	80	25	*	320	328	*	*	*	*	9.07	19.9
KCSM0400951	2	-DIN8	95	25	*	380	388	*	*	*	*	10.77	27.8



KCSM-DIN8

Straight
DIN

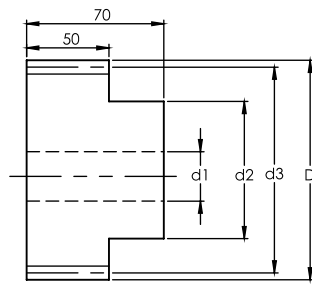

Fig. 1

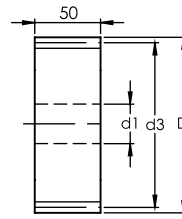

Fig. 2

Dimension: mm

NOTE:
1) ALL THE SURFACES HAVE Ra1.6 SURFACE FINISH.

Series KCSM-DIN8 Straight Soft Pinions
Quality Grade DIN 8

Material S45C / S50C

Code	Fig.	DIN	No. of Teeth	d1	d2	d3	D	W1	W2	k	F _{ta} kN	KG
Module 5												
KCSM0500121	1	-DIN8	12	20	45	60	70	*	*	*	*	1.1
KCSM0500131	1	-DIN8	13	20	45	65	75	*	*	*	*	1.2
KCSM0500141	1	-DIN8	14	20	55	70	80	*	*	*	*	1.4
KCSM0500151	1	-DIN8	15	20	60	75	85	*	*	*	*	1.6
KCSM0500161	1	-DIN8	16	20	60	80	90	*	*	*	1.84	1.7
KCSM0500171	1	-DIN8	17	20	70	85	95	*	*	*	2.19	1.9
KCSM0500181	1	-DIN8	18	20	70	90	100	*	*	*	2.32	2.2
KCSM0500191	1	-DIN8	19	20	70	95	105	*	*	*	2.45	2.4
KCSM0500201	1	-DIN8	20	20	70	100	110	*	*	*	2.58	2.6
KCSM0500211	1	-DIN8	21	20	70	105	115	*	*	*	2.71	2.9
KCSM0500221	1	-DIN8	22	20	80	110	120	*	*	*	2.84	3.1
KCSM0500231	1	-DIN8	23	20	80	115	125	*	*	*	2.96	3.4
KCSM0500241	1	-DIN8	24	20	80	120	130	*	*	*	3.09	3.6
KCSM0500251	1	-DIN8	25	20	80	125	135	*	*	*	3.67	3.9
KCSM0500301	1	-DIN8	30	20	90	150	160	*	*	*	4.40	5.5
KCSM0500361	2	-DIN8	36	30	*	180	190	*	*	*	5.28	7.8
KCSM0500381	2	-DIN8	38	30	*	190	200	*	*	*	5.57	8.6
KCSM0500401	2	-DIN8	40	30	*	200	210	*	*	*	5.87	9.5
KCSM0500451	2	-DIN8	45	30	*	225	235	*	*	*	6.60	11.9
KCSM0500481	2	-DIN8	48	30	*	240	250	*	*	*	7.04	13.5
KCSM0500501	2	-DIN8	50	30	*	250	260	*	*	*	8.86	14.6
KCSM0500521	2	-DIN8	52	30	*	260	270	*	*	*	9.21	15.7
KCSM0500561	2	-DIN8	56	30	*	280	290	*	*	*	9.92	18.1
KCSM0500601	2	-DIN8	60	30	*	300	310	*	*	*	10.63	20.7
KCSM0500761	2	-DIN8	76	30	*	380	390	*	*	*	13.47	32.8
KCSM0500801	2	-DIN8	80	30	*	400	410	*	*	*	14.18	36.3
KCSM0500951	2	-DIN8	95	30	*	475	485	*	*	*	16.83	50.8



KCSM-DIN8

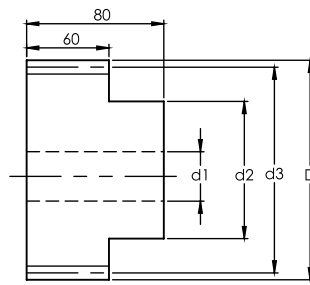

Fig. 1

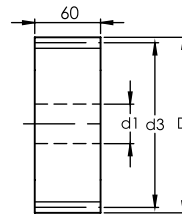

Fig. 2

Dimension: mm

NOTE:
1) ALL THE SURFACES HAVE Ra1.6 SURFACE FINISH.

Series KCSM-DIN8 Straight Soft Pinions
Quality Grade DIN 8

Material S45C / S50C

Straight

DIN

Code	Fig.	DIN	No. of Teeth	d1	d2	d3	D	W1	W2	k	h	F _{ta} kN	KG
Module 6													
KCSM0600151	1	-DIN8	15	20	60	90	102	*	*	*	*	*	2.6
KCSM0600191	1	-DIN8	19	20	80	114	126	*	*	*	*	3.53	3.9
KCSM0600201	1	-DIN8	20	20	90	120	132	*	*	*	*	3.71	4.3
KCSM0600211	1	-DIN8	21	20	90	126	138	*	*	*	*	3.90	4.7
KCSM0600221	1	-DIN8	22	20	100	132	144	*	*	*	*	4.08	5.1
KCSM0600251	1	-DIN8	25	20	110	150	162	*	*	*	*	5.28	6.5
KCSM0600301	2	-DIN8	30	30	*	180	192	*	*	*	*	6.34	9.1
KCSM0600361	2	-DIN8	36	30	*	216	228	*	*	*	*	7.60	12.8



KCSM-DIN8

Straight
DIN

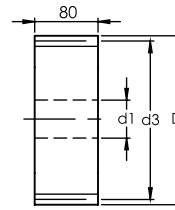
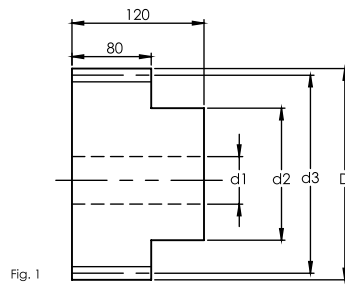

Fig. 1

Fig. 2

Dimension: mm

NOTE:
1) ALL THE SURFACES HAVE Ra1.6 SURFACE FINISH.

Series KCSM-DIN8 Straight Soft Pinions
Quality Grade DIN 8

Material S45C / S50C

Code	Fig.	DIN	No. of Teeth	d1	d2	d3	D	W1	W2	k	h	F _{ta} kN	KG
Module 8													
KCSM0800151	1	-DIN8	15	40	90	120	136	*	*	*	*	*	6.8
KCSM0800181	1	-DIN8	18	40	100	144	160	*	*	*	*	5.94	9.5
KCSM0800201	1	-DIN8	20	40	120	160	176	*	*	*	*	6.60	11.5
KCSM0800241	1	-DIN8	24	40	150	192	208	*	*	*	*	7.92	16.0
KCSM0800251	1	-DIN8	25	40	150	200	216	*	*	*	*	9.39	17.3
KCSM0800301	1	-DIN8	30	40	190	240	256	*	*	*	*	11.26	24.2

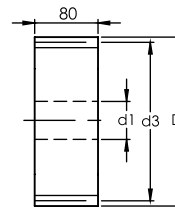
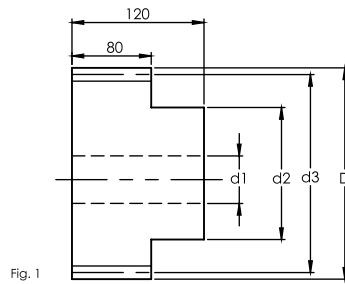

Fig. 1

Fig. 2

Dimension: mm

Code	Fig.	DIN		d1	d2	d3	D	W1	W2	k	h	KG
Module 10												
KCSM1000201	2	-DIN8		40	150	200	220	*	*	*	*	22.4



KASMH-DIN10

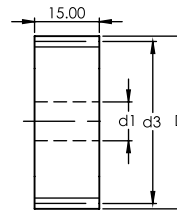
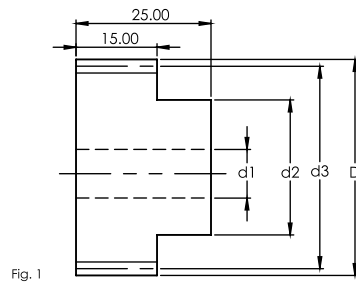

Fig. 1

Fig. 2

Dimension: mm

NOTE:
1) ALL THE SURFACES HAVE R_a 2.4 SURFACE FINISH.

Series KASMH-DIN10 Straight Hardened Pinions
Quality Grade DIN 10

Material SCM415/SCM440
Hardness: HRC 50~55°
Surfaces: Sand-blasted
Other surface treatments are available upon request.



Code	Fig.	DIN	No. of Teeth	d1	d2	d3	D	W1	W2	k	h	F _{ta} kN	KG
Module 1													
KASMH0100121	1	-DIN10	12	6	9	12.0	14.0	*	*	*	*	*	0.1
KASMH0100131	1	-DIN10	13	6	9	13.0	15.0	*	*	*	*	*	0.1
KASMH0100141	1	-DIN10	14	6	11	14.0	16.0	*	*	*	*	*	0.1
KASMH0100151	1	-DIN10	15	6	12	15.0	17.0	*	*	*	*	*	0.1
KASMH0100161	1	-DIN10	16	6	12	16.0	18.0	*	*	*	*	0.58	0.1
KASMH0100171	1	-DIN10	17	6	14	17.0	19.0	*	*	*	*	0.62	0.1
KASMH0100181	1	-DIN10	18	6	15	18.0	20.0	*	*	*	*	0.66	0.1
KASMH0100191	1	-DIN10	19	6	15	19.0	21.0	*	*	*	*	0.75	0.1
KASMH0100201	1	-DIN10	20	6	16	20.0	22.0	*	*	*	*	0.79	0.1
KASMH0100211	1	-DIN10	21	6	16	21.0	23.0	*	*	*	*	0.83	0.1
KASMH0100221	1	-DIN10	22	6	18	22.0	24.0	*	*	*	*	0.87	0.1
KASMH0100231	1	-DIN10	23	6	18	23.0	25.0	*	*	*	*	0.91	0.1
KASMH0100241	1	-DIN10	24	9	20	24.0	26.0	*	*	*	*	0.95	0.1
KASMH0100251	1	-DIN10	25	9	20	25.0	27.0	*	*	*	*	1.10	0.1
KASMH0100301	1	-DIN10	30	9	20	30.0	32.0	*	*	*	*	1.33	0.1
KASMH0100351	1	-DIN10	35	9	25	35.0	37.0	*	*	*	*	1.55	0.2
KASMH0100381	1	-DIN10	38	9	25	38.0	40.0	*	*	*	*	1.91	0.2
KASMH0100401	1	-DIN10	40	9	25	40.0	42.0	*	*	*	*	2.01	0.2
KASMH0100451	1	-DIN10	45	9	30	45.0	47.0	*	*	*	*	2.26	0.3
KASMH0100481	1	-DIN10	48	9	30	48.0	50.0	*	*	*	*	2.33	0.3
KASMH0100501	1	-DIN10	50	9	30	50.0	52.0	*	*	*	*	2.35	0.3
KASMH0100571	1	-DIN10	57	9	40	57.0	59.0	*	*	*	*	2.40	0.4
KASMH0100601	1	-DIN10	60	9	40	60.0	62.0	*	*	*	*	2.42	0.4
KASMH0100761	2	-DIN10	76	10	*	76.0	78.0	*	*	*	*	2.49	0.7
KASMH0100801	2	-DIN10	80	10	*	80.0	82.0	*	*	*	*	2.50	0.8
KASMH0100951	2	-DIN10	95	10	*	95.0	97.0	*	*	*	*	2.55	1.1
KASMH0101001	2	-DIN10	100	10	*	100.0	102.0	*	*	*	*	2.56	1.2
KASMH0101141	2	-DIN10	114	10	*	114.0	116.0	*	*	*	*	2.59	1.6



KASMH-DIN10

Straight
DIN

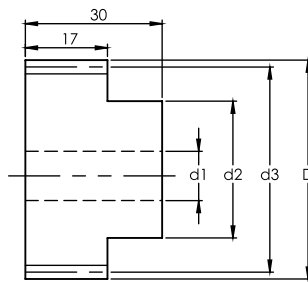

Fig. 1

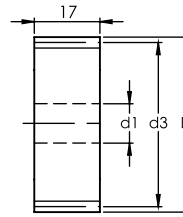

Fig. 2 Dimension: mm

NOTE:
1) ALL THE SURFACES HAVE R_a 2.4 SURFACE FINISH.

Series KASMH-DIN10 Straight Hardened Pinions
Quality Grade DIN 10

Material SCM415/SCM440
Hardness: HRC 50~55°
Surfaces: Sand-blasted
Other surface treatments are available upon request.

Code	DIN	No. of Teeth	d1	d2	d3	D	W1	W2	k	h	F _{ta} kN	KG
Module 1.5												
KASMH0150121	-DIN10	12	6	14	18.0	21.0	*	*	*	*	*	0.1
KASMH0150131	-DIN10	13	6	14	19.5	22.5	*	*	*	*	*	0.1
KASMH0150141	-DIN10	14	6	16	21.0	24.0	*	*	*	*	*	0.1
KASMH0150151	-DIN10	15	6	18	22.5	25.5	*	*	*	*	*	0.1
KASMH0150161	-DIN10	16	6	18	24.0	27.0	*	*	*	*	1.07	0.1
KASMH0150171	-DIN10	17	9	20	25.5	28.5	*	*	*	*	1.14	0.1
KASMH0150181	-DIN10	18	9	20	27.0	30.0	*	*	*	*	1.21	0.1
KASMH0150191	-DIN10	19	9	20	28.5	31.5	*	*	*	*	1.43	0.1
KASMH0150201	-DIN10	20	9	25	30.0	33.0	*	*	*	*	1.50	0.2
KASMH0150211	-DIN10	21	9	25	31.5	34.5	*	*	*	*	1.58	0.2
KASMH0150221	-DIN10	22	9	25	33.0	36.0	*	*	*	*	1.65	0.2
KASMH0150231	-DIN10	23	9	25	34.5	37.5	*	*	*	*	1.73	0.2
KASMH0150241	-DIN10	24	9	25	36.0	39.0	*	*	*	*	1.80	0.2
KASMH0150251	-DIN10	25	9	25	37.5	40.5	*	*	*	*	1.88	0.2
KASMH0150301	-DIN10	30	9	30	45.0	48.0	*	*	*	*	2.56	0.3
KASMH0150351	-DIN10	35	9	30	52.5	55.5	*	*	*	*	2.99	0.4
KASMH0150381	-DIN10	38	9	40	57.0	60.0	*	*	*	*	3.25	0.5
KASMH0150401	-DIN10	40	9	40	60.0	63.0	*	*	*	*	3.42	0.6
KASMH0150451	-DIN10	45	12	50	67.5	70.5	*	*	*	*	3.84	0.7
KASMH0150481	-DIN10	48	12	50	72.0	75.0	*	*	*	*	3.96	0.8
KASMH0150501	-DIN10	50	12	50	75.0	78.0	*	*	*	*	3.99	0.8
KASMH0150571	-DIN10	57	12	60	85.5	88.5	*	*	*	*	4.08	1.1
KASMH0150601	-DIN10	60	12	60	90.0	93.0	*	*	*	*	4.11	1.2
KASMH0150761	-DIN10	76	16	*	114.0	117.0	*	*	*	*	4.23	1.9
KASMH0150801	-DIN10	80	16	*	120.0	123.0	*	*	*	*	4.26	2.1
KASMH0150951	-DIN10	95	20	*	142.5	145.5	*	*	*	*	4.34	2.9



KASMH-DIN10

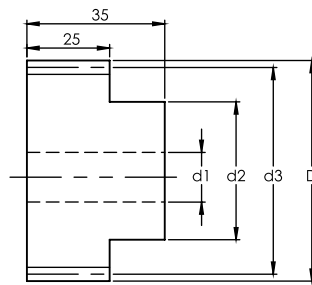

Fig. 1

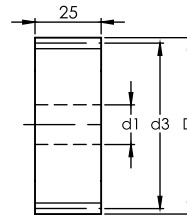

Fig. 2 Dimension: mm

NOTE:
1) ALL THE SURFACES HAVE R_a 2.4 SURFACE FINISH.

Series KASMH-DIN10 Straight Hardened Pinions
Quality Grade DIN 10

Material SCM415/SCM440
Hardness: HRC 50~55°
Other surface treatments are available upon request.



Code	Fig.	DIN	No. of Teeth	d1	d2	d3	D	W1	W2	k	h	F _{ta} kN	KG
Module 2													
KASMH0200121	1	-DIN10	12	9	18	24.0	28.0	*	*	*	*	*	0.1
KASMH0200131	1	-DIN10	13	9	19	26.0	30.0	*	*	*	*	*	0.1
KASMH0200141	1	-DIN10	14	9	19	28.0	32.0	*	*	*	*	*	0.2
KASMH0200151	1	-DIN10	15	9	24.5	30.0	34.0	*	*	*	*	*	0.2
KASMH0200161	1	-DIN10	16	9	25	32.0	36.0	*	*	*	*	2.10	0.2
KASMH0200171	1	-DIN10	17	9	25	34.0	38.0	*	*	*	*	2.23	0.2
KASMH0200181	1	-DIN10	18	9	25	36.0	40.0	*	*	*	*	2.36	0.3
KASMH0200191	1	-DIN10	19	9	25	38.0	42.0	*	*	*	*	2.49	0.3
KASMH0200201	1	-DIN10	20	9	30	40.0	44.0	*	*	*	*	2.63	0.3
KASMH0200211	1	-DIN10	21	9	30	42.0	46.0	*	*	*	*	3.09	0.3
KASMH0200221	1	-DIN10	22	9	30	44.0	48.0	*	*	*	*	3.24	0.4
KASMH0200231	1	-DIN10	23	9	30	46.0	50.0	*	*	*	*	3.39	0.4
KASMH0200241	1	-DIN10	24	12	35	48.0	52.0	*	*	*	*	3.53	0.4
KASMH0200251	1	-DIN10	25	12	35	50.0	54.0	*	*	*	*	3.68	0.5
KASMH0200281	1	-DIN10	28	12	40	56.0	60.0	*	*	*	*	4.12	0.6
KASMH0200301	1	-DIN10	30	12	40	60.0	64.0	*	*	*	*	4.42	0.7
KASMH0200321	1	-DIN10	32	12	40	64.0	68.0	*	*	*	*	5.36	0.7
KASMH0200351	1	-DIN10	35	12	50	70.0	74.0	*	*	*	*	5.86	0.9
KASMH0200361	1	-DIN10	36	12	50	72.0	76.0	*	*	*	*	6.03	0.9
KASMH0200381	1	-DIN10	38	12	50	76.0	80.0	*	*	*	*	6.36	1.0
KASMH0200401	1	-DIN10	40	12	50	80.0	84.0	*	*	*	*	6.70	1.1
KASMH0200451	1	-DIN10	45	12	60	90.0	94.0	*	*	*	*	7.54	1.4
KASMH0200481	1	-DIN10	48	15	70	96.0	100.0	*	*	*	*	7.77	1.6
KASMH0200501	1	-DIN10	50	15	70	100.0	104.0	*	*	*	*	7.83	1.8
KASMH0200561	1	-DIN10	56	15	70	112.0	116.0	*	*	*	*	7.97	2.2
KASMH0200571	1	-DIN10	57	15	70	114.0	118.0	*	*	*	*	7.99	2.3
KASMH0200601	1	-DIN10	60	15	70	120.0	124.0	*	*	*	*	8.06	2.5
KASMH0200761	2	-DIN10	76	20	*	152.0	156.0	*	*	*	*	8.30	3.9
KASMH0200801	2	-DIN10	80	20	*	160.0	164.0	*	*	*	*	8.35	4.4
KASMH0200951	2	-DIN10	95	20	*	190.0	194.0	*	*	*	*	8.50	6.1



KASMH-DIN10

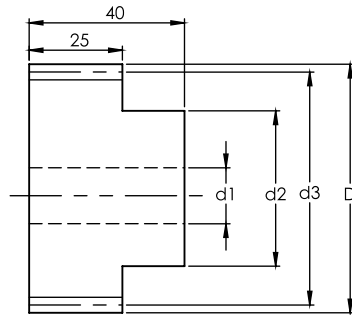

Fig. 1

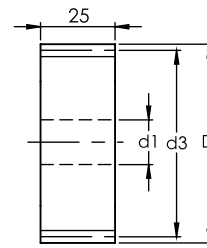

Fig. 2

Dimension: mm

NOTE:
1) ALL THE SURFACES HAVE R_a 2.4 SURFACE FINISH.

Series KASMH-DIN10 Straight Hardened Pinions
Quality Grade DIN 10

Material SCM415/SCM440
Hardness: HRC 50~55°
Surfaces: Sand-blasted
Other surface treatments are available upon request.

Code	Fig.	DIN	No. of Teeth	d1	d2	d3	D	W1	W2	k	h	F _{ta} kN	KG
Module 2.5													
KASMH0250121	1	-DIN10	12	9	20	30.0	35.0	*	*	*	*	*	0.3
KASMH0250131	1	-DIN10	13	9	20	32.5	37.5	*	*	*	*	*	0.3
KASMH0250141	1	-DIN10	14	9	25	35.0	40.0	*	*	*	*	*	0.3
KASMH0250151	1	-DIN10	15	9	25	37.5	42.5	*	*	*	*	*	0.4
KASMH0250161	1	-DIN10	16	9	30	40.0	45.0	*	*	*	*	2.63	0.4
KASMH0250171	1	-DIN10	17	9	30	42.5	47.5	*	*	*	*	3.13	0.5
KASMH0250181	1	-DIN10	18	9	35	45.0	50.0	*	*	*	*	3.31	0.5
KASMH0250191	1	-DIN10	19	12	35	47.5	52.5	*	*	*	*	3.50	0.6
KASMH0250201	1	-DIN10	20	12	35	50.0	55.0	*	*	*	*	3.68	0.6
KASMH0250211	1	-DIN10	21	12	35	52.5	57.5	*	*	*	*	3.86	0.7
KASMH0250221	1	-DIN10	22	12	40	55.0	60.0	*	*	*	*	4.05	0.7
KASMH0250231	1	-DIN10	23	12	40	57.5	62.5	*	*	*	*	4.23	0.8
KASMH0250241	1	-DIN10	24	12	40	60.0	65.0	*	*	*	*	4.42	0.9
KASMH0250251	1	-DIN10	25	12	45	62.5	67.5	*	*	*	*	5.23	0.9
KASMH0250301	1	-DIN10	30	12	50	75.0	80.0	*	*	*	*	6.28	1.3
KASMH0250351	1	-DIN10	35	12	60	87.5	92.5	*	*	*	*	7.33	1.8
KASMH0250381	1	-DIN10	38	12	60	95.0	100.0	*	*	*	*	7.96	2.1
KASMH0250401	1	-DIN10	40	12	70	100.0	105.0	*	*	*	*	8.37	2.3
KASMH0250451	1	-DIN10	45	15	70	112.5	117.5	*	*	*	*	9.42	2.9
KASMH0250481	1	-DIN10	48	15	80	120.0	125.0	*	*	*	*	9.71	3.3
KASMH0250501	1	-DIN10	50	15	80	125.0	130.0	*	*	*	*	9.79	3.5
KASMH0250571	1	-DIN10	57	15	90	142.5	147.5	*	*	*	*	9.99	4.5
KASMH0250601	1	-DIN10	60	15	90	150.0	155.0	*	*	*	*	10.07	5.0
KASMH0250761	1	-DIN10	76	20	*	190.0	195.0	*	*	*	*	10.37	7.9
KASMH0250801	1	-DIN10	80	25	*	200.0	205.0	*	*	*	*	10.43	8.7
KASMH0250951	1	-DIN10	95	25	*	237.5	242.5	*	*	*	*	10.63	12.2



KASMH-DIN10

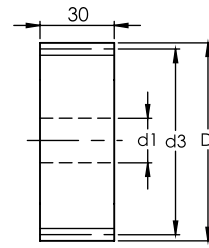
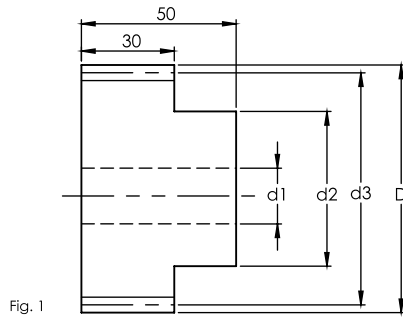

Fig. 2

Dimension: mm

NOTE:

1) ALL THE SURFACES HAVE R_a 2.4 SURFACE FINISH.

Series KASMH-DIN10 Straight Hardened Pinions

Quality Grade DIN 10

Material SCM415/SCM440

Hardness: HRC 50~55°

Surfaces: Sand-blasted

Other surface treatments are available upon request.

Straight
DIN

Code	Fig.	DIN	No. of Teeth	d1	d2	d3	D	W1	W2	k	h	F _{ta} kN	KG
Module3													
KASMH0300121	1	-DIN10	12	14	25	36	42	*	*	*	*	*	0.4
KASMH0300131	1	-DIN10	13	14	25	39	45	*	*	*	*	*	0.5
KASMH0300141	1	-DIN10	14	14	25	42	48	*	*	*	*	*	0.5
KASMH0300151	1	-DIN10	15	14	35	45	51	*	*	*	*	*	0.6
KASMH0300161	1	-DIN10	16	14	35	48	54	*	*	*	*	3.78	0.7
KASMH0300171	1	-DIN10	17	14	42	51	57	*	*	*	*	4.50	0.8
KASMH0300181	1	-DIN10	18	14	45	54	60	*	*	*	*	4.77	0.8
KASMH0300191	1	-DIN10	19	14	45	57	63	*	*	*	*	5.03	0.9
KASMH0300201	1	-DIN10	20	14	45	60	66	*	*	*	*	5.30	1.0
KASMH0300211	1	-DIN10	21	14	45	63	69	*	*	*	*	5.56	1.1
KASMH0300221	1	-DIN10	22	14	50	66	72	*	*	*	*	5.83	1.2
KASMH0300231	1	-DIN10	23	14	50	69	75	*	*	*	*	6.09	1.3
KASMH0300241	1	-DIN10	24	14	50	72	78	*	*	*	*	6.36	1.4
KASMH0300251	1	-DIN10	25	14	60	75	81	*	*	*	*	7.54	1.5
KASMH0300271	1	-DIN10	27	14	60	81	87	*	*	*	*	8.14	1.7
KASMH0300281	1	-DIN10	28	14	60	84	90	*	*	*	*	8.44	1.9
KASMH0300301	1	-DIN10	30	14	60	90	96	*	*	*	*	9.04	2.1
KASMH0300321	1	-DIN10	32	14	60	96	102	*	*	*	*	9.65	2.4
KASMH0300351	1	-DIN10	35	14	80	105	111	*	*	*	*	10.55	2.8
KASMH0300361	1	-DIN10	36	14	80	108	114	*	*	*	*	10.85	3.0
KASMH0300381	1	-DIN10	38	14	80	114	120	*	*	*	*	11.46	3.3
KASMH0300401	1	-DIN10	40	14	80	120	126	*	*	*	*	12.06	3.7
KASMH0300451	2	-DIN10	45	20	*	135	141	*	*	*	*	13.57	4.6
KASMH0300481	2	-DIN10	48	20	*	144	150	*	*	*	*	13.99	5.2
KASMH0300501	2	-DIN10	50	25	*	150	156	*	*	*	*	14.10	5.6
KASMH0300521	2	-DIN10	52	25	*	156	165	*	*	*	*	14.18	6.3
KASMH0300561	2	-DIN10	56	25	*	168	174	*	*	*	*	14.34	7.0
KASMH0300601	2	-DIN10	60	25	*	180	186	*	*	*	*	14.50	8.0
KASMH0300761	2	-DIN10	76	25	*	228	234	*	*	*	*	14.93	12.7
KASMH0300801	2	-DIN10	80	25	*	240	246	*	*	*	*	15.02	14.0
KASMH0300951	2	-DIN10	95	25	*	285	291	*	*	*	*	15.30	19.6



KASMH-DIN10

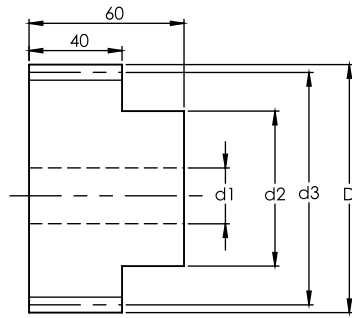

Fig. 1

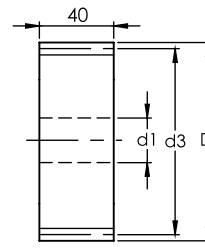

Fig. 2

Dimension: mm

NOTE:
1) ALL THE SURFACES HAVE R_a 2.4 SURFACE FINISH.

Straight
DIN

Series KASMH-DIN10 Straight Hardened Pinions
Quality Grade DIN 10

Material SCM415/SCM440
Hardness: HRC 50~55°
Surfaces: Sand-blasted
Other surface treatments are available upon request.

Code	Fig.	DIN	No. of Teeth	d1	d2	d3	D	W1	W2	k	h	F _{ta} kN	KG
Module 4													
KASMH0400121	1	-DIN10	12	16	35	48	56	*	*	*	*	*	0.9
KASMH0400131	1	-DIN10	13	16	35	52	60	*	*	*	*	*	1.0
KASMH0400141	1	-DIN10	14	16	45	56	64	*	*	*	*	*	1.1
KASMH0400151	1	-DIN10	15	16	45	60	68	*	*	*	*	*	1.3
KASMH0400161	1	-DIN10	16	16	45	64	72	*	*	*	*	6.72	1.4
KASMH0400171	1	-DIN10	17	16	50	68	76	*	*	*	*	8.01	1.6
KASMH0400181	1	-DIN10	18	16	50	72	80	*	*	*	*	8.48	1.8
KASMH0400191	1	-DIN10	19	16	60	76	84	*	*	*	*	8.95	2.0
KASMH0400201	1	-DIN10	20	16	60	80	88	*	*	*	*	9.42	2.1
KASMH0400211	1	-DIN10	21	16	70	84	92	*	*	*	*	9.89	2.3
KASMH0400221	1	-DIN10	22	16	70	88	96	*	*	*	*	10.36	2.6
KASMH0400231	1	-DIN10	23	16	75	92	100	*	*	*	*	10.83	2.8
KASMH0400241	1	-DIN10	24	16	75	96	104	*	*	*	*	11.30	3.0
KASMH0400251	1	-DIN10	25	16	75	100	108	*	*	*	*	13.40	3.2
KASMH0400301	1	-DIN10	30	16	*	120	128	*	*	*	*	16.08	4.5
KASMH0400381	2	-DIN10	38	25	*	152	160	*	*	*	*	20.36	7.1
KASMH0400401	2	-DIN10	40	25	*	160	168	*	*	*	*	21.44	7.8
KASMH0400451	2	-DIN10	45	25	*	180	188	*	*	*	*	24.12	9.8
KASMH0400481	2	-DIN10	48	25	*	192	200	*	*	*	*	24.87	11.1
KASMH0400501	2	-DIN10	50	25	*	200	208	*	*	*	*	25.06	12.0
KASMH0400521	2	-DIN10	52	25	*	208	216	*	*	*	*	25.20	12.9
KASMH0400561	2	-DIN10	56	25	*	224	232	*	*	*	*	25.49	14.9
KASMH0400601	2	-DIN10	60	25	*	240	248	*	*	*	*	25.78	17.1
KASMH0400761	2	-DIN10	76	25	*	304	312	*	*	*	*	26.55	27.0
KASMH0400801	2	-DIN10	80	25	*	320	328	*	*	*	*	26.71	29.8
KASMH0400951	2	-DIN10	95	25	*	380	388	*	*	*	*	27.20	41.8



KASMH-DIN10

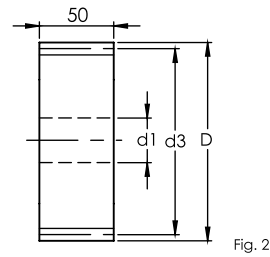
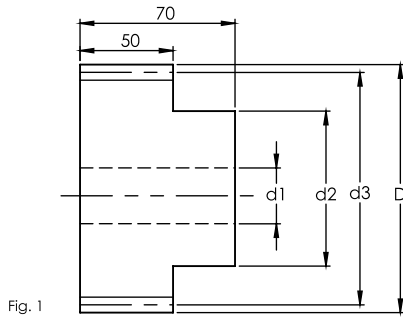

Dimension: mm

NOTE:
1) ALL THE SURFACES HAVE R_a 2.4 SURFACE FINISH.

Series KASMH-DIN10 Straight Hardened Pinions
Quality Grade DIN 10

Material SCM415/SCM440
Hardness: HRC 50~55°
Surfaces: Sand-blasted
Other surface treatments are available upon request.



Code	Fig.	DIN	No. of Teeth	d1	d2	d3	D	W1	W2	k	h	F _{ta} kN	KG
Module 5													
KASMH0500121	1	-DIN10	12	20	45	60	70	*	*	*	*	*	1.6
KASMH0500131	1	-DIN10	13	20	45	65	75	*	*	*	*	*	1.8
KASMH0500141	1	-DIN10	14	20	55	70	80	*	*	*	*	*	2.1
KASMH0500151	1	-DIN10	15	20	60	75	85	*	*	*	*	*	2.3
KASMH0500161	1	-DIN10	16	20	60	80	90	*	*	*	*	10.50	2.6
KASMH0500171	1	-DIN10	17	20	70	85	95	*	*	*	*	12.51	2.9
KASMH0500181	1	-DIN10	18	20	70	90	100	*	*	*	*	13.25	3.2
KASMH0500191	1	-DIN10	19	20	70	95	105	*	*	*	*	13.98	3.6
KASMH0500201	1	-DIN10	20	20	70	100	110	*	*	*	*	14.72	3.9
KASMH0500211	1	-DIN10	21	20	70	105	115	*	*	*	*	15.45	4.3
KASMH0500221	1	-DIN10	22	20	80	110	120	*	*	*	*	16.19	4.7
KASMH0500231	1	-DIN10	23	20	80	115	125	*	*	*	*	16.92	5.1
KASMH0500241	1	-DIN10	24	20	80	120	130	*	*	*	*	17.66	5.5
KASMH0500251	1	-DIN10	25	20	80	125	135	*	*	*	*	20.93	5.9
KASMH0500301	1	-DIN10	30	20	90	150	160	*	*	*	*	25.12	8.3
KASMH0500361	2	-DIN10	36	30	*	180	190	*	*	*	*	30.14	11.7
KASMH0500381	2	-DIN10	38	30	*	190	200	*	*	*	*	31.82	12.9
KASMH0500401	2	-DIN10	40	30	*	200	210	*	*	*	*	33.49	14.3
KASMH0500451	2	-DIN10	45	30	*	225	235	*	*	*	*	37.68	17.9
KASMH0500481	2	-DIN10	48	30	*	240	250	*	*	*	*	38.86	20.2
KASMH0500501	2	-DIN10	50	30	*	250	260	*	*	*	*	39.15	21.9
KASMH0500521	2	-DIN10	52	30	*	260	270	*	*	*	*	39.38	23.6
KASMH0500561	2	-DIN10	56	30	*	280	290	*	*	*	*	39.89	27.2
KASMH0500601	2	-DIN10	60	30	*	300	310	*	*	*	*	40.29	31.1
KASMH0500761	2	-DIN10	76	30	*	380	390	*	*	*	*	41.48	49.2
KASMH0500801	2	-DIN10	80	30	*	400	410	*	*	*	*	41.73	54.4
KASMH0500951	2	-DIN10	95	30	*	475	485	*	*	*	*	42.50	76.1



KASMH-DIN10

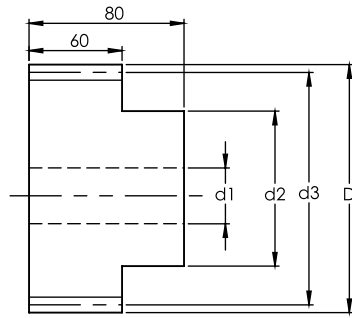

Fig. 1

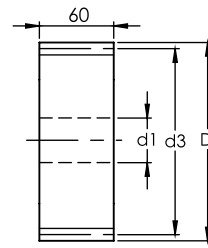

Fig. 2

Dimension: mm

NOTE:

1) ALL THE SURFACES HAVE R_a 2.4 SURFACE FINISH.

Series KASMH-DIN10 Straight Hardened Pinions
Quality Grade DIN 10

Material SCM415/SCM440

Hardness: HRC 50~55°

Surfaces: Sand-blasted

Other surface treatments are available upon request.

Code	Fig.	DIN	No. of Teeth	d1	d2	d3	D	W1	W2	k	h	F _{ta} kN	KG
Module 6													
KASMH0600151	1	-DIN10	15	20	60	90	102	*	*	*	*	*	3.8
KASMH0600191	1	-DIN10	19	20	80	114	126	*	*	*	*	20.13	5.9
KASMH0600201	1	-DIN10	20	20	90	120	132	*	*	*	*	21.19	6.4
KASMH0600211	1	-DIN10	21	20	90	126	138	*	*	*	*	22.25	7.0
KASMH0600221	1	-DIN10	22	20	100	132	144	*	*	*	*	23.31	7.7
KASMH0600251	1	-DIN10	25	20	110	150	162	*	*	*	*	30.14	9.7
KASMH0600301	2	-DIN10	30	30	*	180	192	*	*	*	*	36.17	13.6
KASMH0600361	2	-DIN10	36	30	*	216	228	*	*	*	*	43.41	19.2



KASMH-DIN10

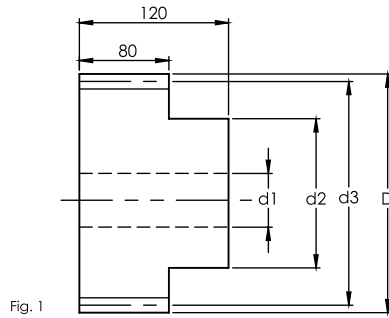

Fig. 1

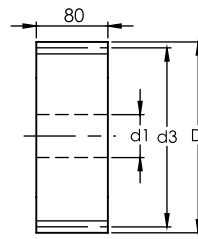

Fig. 2

Dimension: mm

NOTE:
1) ALL THE SURFACES HAVE R_a 2.4 SURFACE FINISH.

Series KASMH-DIN10 Straight Hardened Pinions
Quality Grade DIN 10

Material SCM415/SCM440
Hardness: HRC 50~55°
Surfaces: Sand-blasted
Other surface treatments are available upon request.



Code	Fig.	DIN	No. of Teeth	d1	d2	d3	D	W1	W2	k	h	F _{ta} kN	KG
Module 8													
KASMH0800151	1	-DIN10	15	40	90	120	136	*	*	*	*	*	10.3
KASMH0800181	1	-DIN10	18	40	100	144	160	*	*	*	*	33.91	14.2
KASMH0800201	1	-DIN10	20	40	120	160	176	*	*	*	*	37.68	17.2
KASMH0800241	1	-DIN10	24	40	150	192	208	*	*	*	*	45.21	24.0
KASMH0800251	1	-DIN10	25	40	150	200	216	*	*	*	*	53.59	25.9
KASMH0800301	1	-DIN10	30	40	190	240	256	*	*	*	*	64.31	36.4

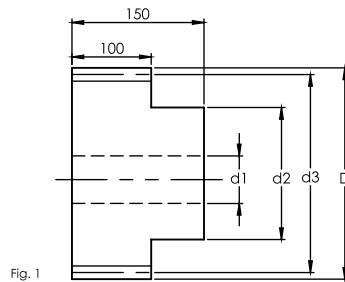

Fig. 1

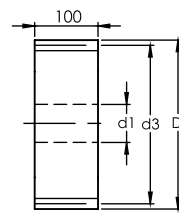

Fig. 2

Dimension: mm

Code	Fig.	DIN	No. of Teeth	d1	d2	d3	D	W1	W2	k	h	F _{ta} kN	KG
Module 10													
KASMH1000201	2	-DIN10	20	40	150	200	220	*	*	*	*	58.87	33.6



KAHFGH-DIN6

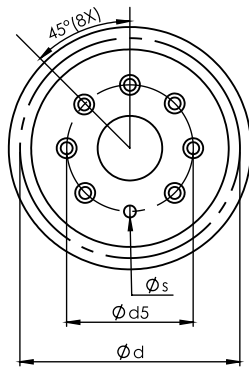

Fig. 1

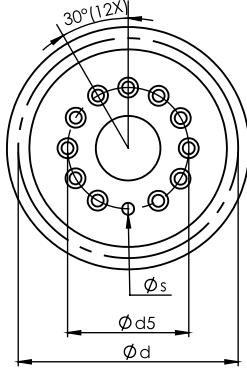

Fig. 2

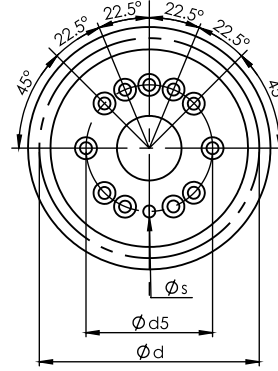
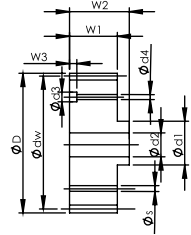

Fig. 3



Dimension: mm

Helical

DIN

Series KAHFGH-DIN6 Helical Flange Teeth Ground Pinions
Quality Grade DIN 6

Material SCM415/ SCM440
Hardness: HRC 50~55°
Teeth Ground after Hardening

Code	Fig.	DIN	No. of Teeth	X^0 Shift Coefficient	D	d Pitch Dia.	d^w Working Pitch Dia.	d1	d2	d3	d4	d5	W1	W2	W3	F_{ta} kN
Module 2																
KAHFGH0200261	1	-DIN6	26	0.407	60.800	55.174	56.800	20.0	16.2	9.5	5.5	31.5	26	29	12.0	11.52
KAHFGH0200262	1	-DIN6	26	0.407	60.802	55.174	56.802	20.0	16.0	9.5	5.5	31.5	26	31	11.0	11.52
KAHFGH0200271	1	-DIN6	27	0.000	61.296	57.296	57.296	20.0	16.2	9.5	5.5	31.5	30	33	11.0	10.95
KAHFGH0200272	1	-DIN6	27	0.000	61.296	57.296	57.296	20.0	16.0	9.5	5.5	31.5	26	31	11.0	11.99
KAHFGH0200291	1	-DIN6	29	0.415	67.200	61.540	63.200	20.0	16.2	9.5	5.5	31.5	26	29	12.0	12.25
KAHFGH0200292	1	-DIN6	29	0.415	67.200	61.540	63.200	25.0	20.3	11.0	6.6	40.0	26	29	10.5	12.25
KAHFGH0200293	1	-DIN6	29	0.415	67.200	61.540	63.200	20.0	16.0	9.5	5.5	31.5	26	31	11.0	12.25
KAHFGH0200331	1	-DIN6	33	0.393	75.599	70.028	71.599	31.5	23.7	11.0	6.6	50.0	26	29	14.0	12.62
KAHFGH0200332	1	-DIN6	33	0.393	75.599	70.028	71.600	31.5	20.0	11.0	6.6	50.0	26	31	11.0	12.62
KAHFGH0200351	1	-DIN6	35	0.382	79.800	74.272	75.800	20.0	16.2	9.5	5.5	31.5	26	29	12.0	12.78
KAHFGH0200352	1	-DIN6	35	0.382	79.800	74.272	75.800	20.0	16.0	9.5	5.5	31.5	26	31	11.0	12.78
KAHFGH0200361	1	-DIN6	36	0.000	80.394	76.394	76.394	31.5	23.7	11.0	6.6	50.0	30	33	8.0	14.83
KAHFGH0200362	1	-DIN6	36	0.000	80.394	76.394	76.394	31.5	20.0	11.0	6.6	50.0	26	31	11.0	12.85
KAHFGH0200371	1	-DIN6	37	0.421	84.200	78.517	80.200	31.5	23.7	11.0	6.6	50.0	26	29	14.0	12.93
KAHFGH0200372	2	-DIN6	37	0.421	84.200	78.517	80.200	31.5	23.7	11.0	6.6	50.0	26	29	14.0	12.93
KAHFGH0200373	1	-DIN6	37	0.421	84.200	78.517	80.200	31.5	20.0	11.0	6.6	50.0	26	31	11.0	12.93
Module 3																
KAHFGH0300311	2	-DIN6	31	0.354	106.800	98.676	100.800	31.5	23.7	11.0	6.6	50.0	31	35	14.0	22.25
KAHFGH0300312	1	-DIN6	31	0.354	106.800	98.676	100.800	31.5	23.7	11.0	6.6	50.0	31	35	14.0	22.25
KAHFGH0300313	1	-DIN6	31	0.354	106.800	98.676	100.800	31.5	20.0	11.0	6.6	50.0	31	36	11.0	22.25
KAHFGH0300314	3	-DIN6	31	0.354	106.800	98.676	100.800	40.0	31.5	11.0	6.6	63.0	31	36	11.0	22.25
KAHFGH0300351	2	-DIN6	35	0.365	119.600	111.409	113.600	50.0	32.2	14.0	9.0	80.0	31	35	10.5	22.86
KAHFGH0300352	3	-DIN6	35	0.365	119.598	111.409	113.598	40.0	31.5	11.0	6.6	63.0	31	36	11.0	22.86
KAHFGH0300401	2	-DIN6	40	0.379	135.599	127.324	129.599	50.0	32.2	14.0	9.0	80.0	31	35	10.5	23.46
KAHFGH0300402	3	-DIN6	40	0.379	135.598	127.324	129.598	40.0	31.5	11.0	6.6	63.0	31	36	11.0	23.46
KAHFGH0300403	2	-DIN6	40	0.379	135.598	127.324	129.598	50.0	40.0	14.0	9.0	80.0	31	36	11.0	23.46
Module 4																
KAHFGH0400301	2	-DIN6	30	0.000	135.324	127.324	127.324	50.0	32.2	14.0	9.0	80.0	45	49	9.5	42.75
KAHFGH0400302	3	-DIN6	30	0.000	135.324	127.324	127.324	40.0	32.2	14.0	9.0	63.0	45	49	9.5	42.75
KAHFGH0400303	2	-DIN6	30	0.000	135.324	127.324	127.234	50.0	40.0	14.0	9.0	80.0	41	46	16.0	38.95
KAHFGH0400381	2	-DIN6	38	0.240	171.200	161.277	163.200	80.0	56.1	17.5	11.0	125.0	41	45	10.5	40.98
KAHFGH0400382	2	-DIN6	38	0.24	171.197	161.277	163.197	80.0	60.0	17.5	11.0	125.0	41	46	16.0	40.98
Module 5																
KAHFGH0500211	2	-DIN6	21	0.000	121.109	111.409	111.409	50.0	32.2	14.0	9.0	80.0	59	64	11.5	52.04
KAHFGH0500212	2	-DIN6	21	0.000	121.409	111.409	111.409	50.0	40.0	14.0	9.0	80.0	51	56	16.0	44.98
KAHFGH0500361	2	-DIN6	36	0.000	200.986	190.986	190.986	80.0	56.1	17.5	11.0	125.0	55	60	12.5	67.96
KAHFGH0500362	2	-DIN6	36	0.000	200.986	190.986	190.986	80.0	60.0	17.5	11.0	125.0	51	56	16.0	50.66

※Weight only for reference. Actual scale should be Weighing.

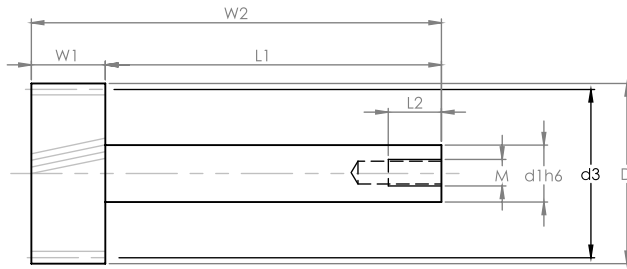

Fig. 1

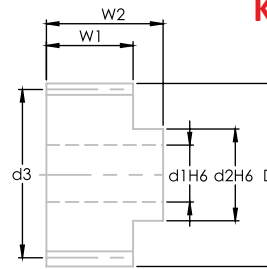

Fig. 2

KASGH-CP-DIN6

Dimension: mm

NOTE:
 1) ALL THE SURFACES HAVE R_a 0.8 SURFACE FINISH.
 2) ALL THE SURFACES ARE GROUND.

Series KASGH-CP-DIN6 Straight Teeth Ground
 Quality Grade DIN6

Material SCM415/SCM440
 Hardness: HRC 50~55°
 Teeth Ground after Hardening

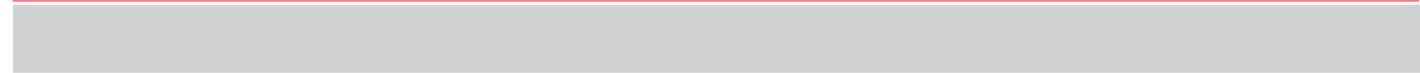

CP 5

KASGH-CP0500201	1	-DIN6	1.5915	20	20h6	*	31.831	35.014	11.5	90	78.5	19	M8	1.87	1.4
KASGH-CP0500202	1	-DIN6	1.5915	20	20h6	*	31.831	35.014	14.5	90	75.5	19	M8	2.07	1.4
KASGH-CP0500203	2	-DIN6	1.5915	20	10h6	25	31.831	35.014	14.5	23	8.5	*	*	2.07	0.5

CP 7.5

KASGH-CP0750201	1	-DIN6	2.3873	20	25h6	*	47.746	52.520	19.5	108	88.5	22	M10	4.18	3.7
KASGH-CP0750202	2	-DIN6	2.3873	20	15h7	40	47.746	52.520	19.5	30	10.5	*	*	4.18	1.4

CP 10

KASGH-CP1000201	1	-DIN6	3.1831	20	40h6	*	63.662	70.028	29.5	162	132.5	28	M12	8.44	9.8
KASGH-CP1000202		-DIN6	3.1831	20	15h7	50	63.662	70.028	29.5	43	13.5	*	*	8.44	3.7

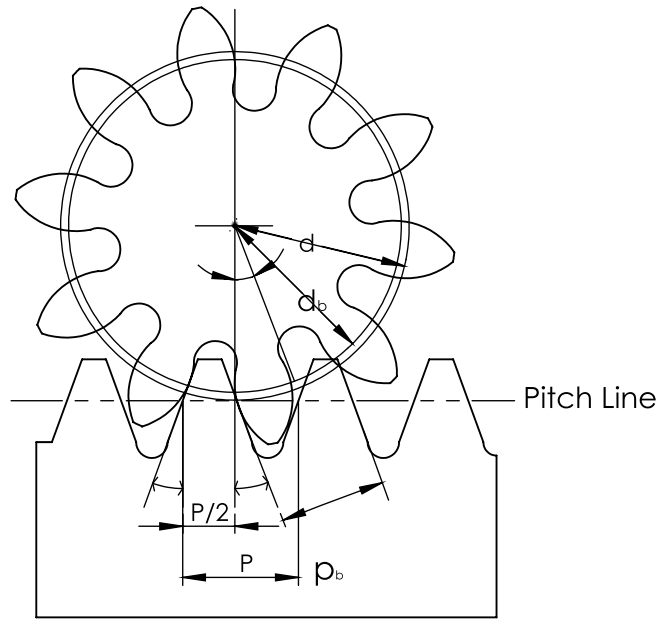

Module	m
Pressure Angle	$= 20^\circ$
Addendum	$h_a = m$
Dedendum	$h_r \geq 1.25m$
Whole Depth	$h \geq 2.25m$
Working Tooth Depth	$h_w = 2.00m$
Clearance	$c = 0.25m$
Circular Pitch	$p = m$
Base Circle Pitch	$p_b = p \cos$
Standard Circle Dia	$d = mz$
Base Circle Diameter	$d_b = d \cos$
r_f = Root Radius	
S = Circular Tooth Thickness	

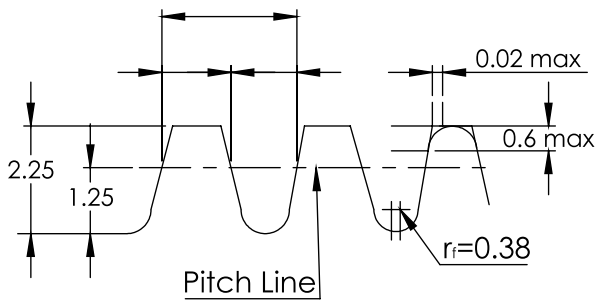

Fig. 1-1 The Basic Metric Rack From ISO 53 Normalized for Module 1

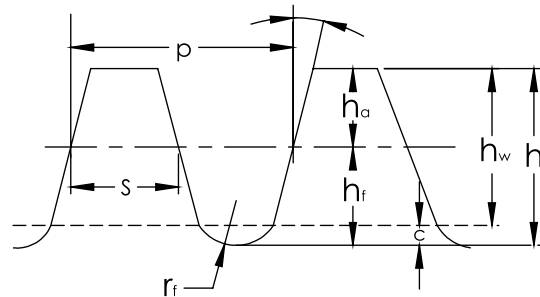

Fig. 1-2 The Basic Inch Diametral Pitch Rack Normalized for 1 Diametral Pitch



Straight Gear Calculation

No.	Description	Symbol	Formula	Example	
				Small	Big
1	Module	m		2.25	
2	Pressure Angle	α		20	
3	No. of Teeth	z		16	20
4	Center Distance	a	$(Z_1+Z_2)m/2$	40.5	
5	Standard Circle Diameter	d	zm	36	45
6	Base Circle Diameter	d_b	$d \cos \alpha$	33.8289	42.2862
7	Addendum	h_a	$1.00m$	2.25	2.25
8	Whole Depth	h	$2.55m$	5.0625	5.0625
9	Addendum Circle Diameter	d_a	$d+2.5m$	40.5	49.5
10	Diameter of Root Circle	d_f	$d - 2.5m$	30.375	39.375



Straight Gear Calculation

No.	Description	Symbol	Formula	Example	
1	Module	m		2.25	
2	Center Distance	a		45	
3	Speed Ratio	i		1.5	
4	Sum of Teeth No.	$Z_1 + Z_2$	$\frac{2a}{m}$	40	
5	Teeth No.	Z	$\frac{Z_1+Z_2}{i+1}$ $\frac{i(Z_1+Z_2)}{i+1}$	16	24



Helical Gear Calculation

Appendix

No.	Description	Symbol	Formula	Example	
				Small	Big
1	Module	m_n		2.5	
2	Pressure Angle	α_n		20°	
3	Standard Cylinder Helical Angle	β		15°	
4	No. of Teeth (Direction)	Z		15 (L)	24 (R)
5	Axis Right Angle Pressure Angle	α_t	$\tan^{-1} \left(\frac{\tan \alpha_n}{\cos \beta} \right)$	20.6469°	
6	Teeth Right Angle Profile Shift Factor	X_n		0.12012	0
7	Involute Function of a' Angle	$\text{inv } \alpha'_t$	$2 \tan \alpha_n \left(\frac{X_{n1} + X_{n2}}{Z_1 + Z_2} \right) + \text{inv } \alpha_n$	0.018695	
8	Axis Right Angle Contact of Pressure Angle	α'_t	Involute Function Chart	21.511	
9	Center Distance Correction Factor	y	$\frac{Z_1 + Z_2}{2 \cos \beta} \left(\frac{\cos \alpha_t}{\cos \alpha'_t} - 1 \right)$	0.084598	
10	Center Distance	a	$\left(\frac{Z_1 + Z_2}{2 \cos \beta} + y \right) m_n$	50.764	
11	Standard Circle Diameter	d	$\frac{z m_n}{\cos \beta}$	38.822	62.117
12	Base Circle Diameter	d_b	$d \cos \alpha_t$	36.329	58.127
13	Contact Standard Circle Diameter	d'	$\frac{d_b}{\cos \alpha'_t}$	39.049	62.478
14	Addendum	h_{a1} h_{a2}	$(1 + X_1) m_n$ $(1 + X_2) m_n$	5.895	5.625
15	Whole Depth	h	$2.25 m_n$	6.748	
16	Addendum Circle Diameter	d_a	$d + 2h_a$	44.423	67.116
17	Diameter of Root Circle	d_f	$d_a - 2h$	33.173	55.867

Helical Gear Calculation

No.	Description	Symbol	Formula	Example
1	Center Distance	a		125
2	Center Distance Correction Factor	y	$\frac{a}{m_n} - \frac{Z_1 + Z_2}{2 \cos \beta}$	0.097447
3	Axis Right Angle Contact of Pressure Angle	α'_t	$\cos^{-1} \left(\frac{2 \cos \alpha_n}{\frac{Z_1 + Z_2}{Z_1 + Z_2} + 1} \right)$	23.1126°
4	Sum of Profile Shift Factor	$X_{n1} + X_{n2}$	$\frac{(Z_1 + Z_2)(\text{inv } \alpha'_t - \text{inv } \alpha_n)}{2 \tan \alpha_n}$	0.09809
5	Teeth Right Angle Profile Shift Factor	X_n		0.09809 0



Overload Factor Ka

Impact from Prime Mover	Impact From Load Side Machine		
	Uniform Load	Mediem Impact t Load	Heavy Impact Load
Uniform Load (Motor, Turbine, hydraulic Motor)	1	1.25	1.75
Light Impact Load (Multicylinder Engine)	1.25	1.5	2
Medium Impact Load (Single Cyliner Engine)	1.5	1.75	2.25

The overload factor is used to correct the impact caused by the mechanical power output and the reference value for the influence of the tooth stress.

Life Factor KL

Number of Cyclic Repetitions	Hardness HRC		
	≤ 20°	≥ 20°	≥ 45°
Under 10,000	1.4	1.5	1.5
Approx. 10 ⁵	1.2	1.4	1.5
Approx. 10 ⁶	1.1	1.1	1.1
Approx. 10 ⁷	1.0	1.0	1.0

Radial Contact Ratio of Standard Spur Gear

	12	15	20	25	30	35	40	45	50	55	60	65	70	75	80	85	90	95	100	110	120		
12	1.420																						
15	1.451	1.481																					
20	1.489	1.519	1.557																				
25	1.516	1.547	1.584	1.612																			
30	1.537	1.567	1.605	1.633	1.654																		
35	1.553	1.584	1.622	1.649	1.670	1.687																	
40	1.567	1.597	1.635	1.663	1.684	1.700	1.714																
45	1.578	1.609	1.646	1.674	1.695	1.711	1.725	1.736															
50	1.588	1.618	1.656	1.683	1.704	1.721	1.734	1.745	1.755														
55	1.596	1.626	1.664	1.691	1.712	1.729	1.742	1.753	1.763	1.771													
60	1.603	1.633	1.671	1.698	1.719	1.736	1.749	1.760	1.770	1.778	1.785												
65	1.609	1.639	1.677	1.704	1.725	1.742	1.755	1.766	1.776	1.784	1.791	1.797											
70	1.614	1.645	1.682	1.710	1.731	1.747	1.761	1.772	1.781	1.789	1.796	1.802	1.808										
75	1.619	1.649	1.687	1.714	1.735	1.752	1.765	1.777	1.786	1.794	1.801	1.807	1.812	1.817									
80	1.623	1.654	1.691	1.719	1.740	1.756	1.770	1.781	1.790	1.798	1.805	1.811	1.817	1.821	1.826								
85	1.627	1.657	1.695	1.723	1.743	1.760	1.773	1.785	1.794	1.802	1.809	1.815	1.821	1.825	1.830	1.833							
90	1.630	1.661	1.699	1.726	1.747	1.764	1.777	1.788	1.798	1.806	1.813	1.819	1.824	1.829	1.833	1.837	1.840						
95	1.634	1.664	1.702	1.729	1.750	1.767	1.780	1.791	1.801	1.809	1.816	1.822	1.827	1.832	1.836	1.840	1.844	1.847					
100	1.636	1.667	1.705	1.732	1.753	1.770	1.783	1.794	1.804	1.812	1.819	1.825	1.830	1.835	1.839	1.843	1.846	1.850	1.853				
110	1.642	1.672	1.710	1.737	1.758	1.775	1.788	1.799	1.809	1.817	1.824	1.830	1.835	1.840	1.844	1.848	1.852	1.855	1.858	1.863			
120	1.646	1.676	1.714	1.742	1.762	1.779	1.792	1.804	1.813	1.821	1.828	1.834	1.840	1.844	1.849	1.852	1.856	1.859	1.862	1.867	1.871		
RACK	1.701	1.731	1.769	1.797	1.817	1.834	1.847	1.859	1.868	1.876	1.883	1.889	1.894	1.899	1.903	1.907	1.911	1.914	1.917	1.926			

ISO Table 17-1

(α = 20°)





Strength and Durability of Gears

Strength and Durability of Gears

The strength of gears is commonly illustrated with bending strength and surface durability. Both are important on application. In particular, when applications are severe, each parameter requires further discussion.

The following formulas are based on standards of JGMA (Japanese Gear Manufacturer Association). The specifications below are for reference only.

JGMA 401-01 Bending Strength Formula of Spur Gears and Helical Gears JGMA 402-01 Surface Durability Formula of Spur Gears and Helical Gears

Bending strength and durability specifications are usually used with straight and helical gears (including racks and pinions) in manufacturing industry within the ranges below:

Module: m 1.5 to 25 mm
 Pitch Diameter: d 25 to 3200 mm
 Tangential Speed: v \leq 25 m/sec
 Rotating Speed: n \leq 3600 rpm

Conversion Formulas: Power, Torque and Force

Gear strength and durability relate to the power and forces to be transmitted. The calculation of tangential force are based on pitch circle, F_t (kgf), power, P(kw), and torque, T(kgf•m).

Formula Below:

$$F_t = \frac{102P}{v} = \frac{19.5 \times 10^6 P}{d_w n} = \frac{2000T}{d_w}$$

$$P = \frac{F_t}{102} = \frac{10^{-6}}{1.95} F_t d_w n$$

$$T = \frac{F_t d_w}{2000} = \frac{947P}{n}$$

Where v: Tangential Speed of Working Pitch Circle

$$v = \frac{d_w n}{19100} \text{ (m/sec)}$$

dw: Working Pitch Diameter (mm)

n: Rotating Speed (rpm)

Product Selection Calculation:

1. The calculation method of the above tangential force F_t can be calculated according to different input conditions;
2. Each item in the catalogue provides the maximum allowable tangential force F_{ta} for the design comparison for users;
3. When using F_{ta} , depending on the conditions of use, it is necessary to correct the load factor K_a and the life factor K_L provided in the catalog;

$$F'_{ta} = \frac{F_{ta}}{K_a \times K_L}$$

4. F_t value must be less than F'_{ta}

5. Note that the F_{ta} unit on the product catalog is kN, and the tangential force F_t is calculated in kgf, and the unit conversion is required when comparing.

Remark:

1kgf= 9.807 N= 0.0098 kN

1kN= 101.972 kgf



Steel Hardness Conversion Chart

Brinell HB	Rockwell HRC	Rockwell HRB	Vickers HV
760	70		
752	69		
745	68		
746	67		
735	66		
711	65		
695	64		
681	63		
658	62		
642	61		
627	60		
613	59		
601	58	746	
592	57	727	
572	56	694	
552	55	649	
534	54	120	589
513	53	119	567
504	52	118	549
486	51	118	531
469	50	117	505
468	49	117	497
456	48	116	490
445	47	115	474
430	46	115	458
419	45	114	448
415	44	114	438
402	43	114	424
388	42	113	406
375	41	112	393
373	40	111	388
360	39	111	376
348	38	110	361
341	37	109	351
331	36	109	342
322	35	108	332
314	34	108	320
308	33	107	311
300	32	107	303
290	31	106	292
277	30	105	285
271	29	104	277
264	28	103	271
262	27	103	262
255	26	102	258
250	25	101	255
245	24	100	252
240	23	100	247
233	22	99	241
229	21	98	235
223	20	97	227
216	19	96	222
212	18	95	218
208	17	95	210

Steel Hardness Conversion Chart

Brinell HB	Rockwell HRC	Rockwell HRB	Vickers HV
199	15	93	199
191	14	92	197
190	13	92	186
186	12	91	184
183	11	90	183
180	10	89	180
175	9	88	178
170	7	87	175
167	6	86	172
166	5	86	168
163	4	85	162
160	3	84	160
156	2	83	158
154	1	82	152

Since all materials and testing instruments are different, all values are for reference only.





Conversion Table for Gear Pitch and Module

Appendix

Conversion Table for Gear Pitch and Module				Conversion Table for Gear Pitch and Module				Conversion Table for Gear Pitch and Module			
Diametral Pitch	Circular Pitch (CP)		Module	Diametral Pitch	Circular Pitch (CP)		Module	Diametral Pitch	Circular Pitch (CP)		Module
DP	in	mm	M	DP	in	mm	M	DP	in	mm	M
1	3.1416	79.796	25.4	3	1.0472	26.599	8.4667	10.6395	0.2953	7.5	2.3873
1.0053	3.1250	79.375	25.2658	3.0691	1.0236	26	8.2761	11	0.2856	7.2540	2.3091
1.0160	3.0921	78.540	25	3.1416	1	25.4	8.0851	11.2889	0.2783	7.0690	2.2500
1.0472	3	76.200	24.2552	3.1750	0.9895	25.133	8	11.3995	0.2756	7	2.2282
1.0583	2.9684	75.398	24	3.1919	0.9843	25	7.9577	12	0.2618	6.6500	2.1167
1.0640	2.9528	75	23.8732	3.2500	0.9666	24.553	7.8154	12.2764	0.2559	6.5	2.0690
1.0927	2.8750	73.025	23.2446	3.3249	0.9449	24	7.6394	12.5664	0.2500	6.3500	2.0213
1.1399	2.7559	70	22.2817	3.3510	0.9375	23.813	7.5798	12.7	0.2474	6.2830	2
1.1424	2.7500	69.850	22.2339	3.5	0.8976	22.799	7.2571	13	0.2417	6.1380	1.9538
1.1545	2.7211	69.115	22	3.5904	0.8750	22.225	7.0744	13.2994	0.2362	6	1.9099
1.1968	2.6250	66.675	21.2233	3.6271	0.8661	22	7.0028	14	0.2244	5.7	1.8143
1.2276	2.5591	65	20.6901	3.6286	0.8658	21.991	7	14.5084	0.2165	5.5	1.7507
1.2500	2.5133	63.837	20.3200	3.7500	0.8378	21.279	6.7733	14.5143	0.2164	5.4980	1.7500
1.2566	2.5	63.5	20.2127	3.8666	0.8125	20.638	6.5691	15	0.2094	5.3200	1.6933
1.2700	2.4737	62.832	20	3.9898	0.7874	20	6.3662	15.9593	0.1969	5	1.5915
1.3228	2.3750	60.325	19.2020	4	0.7854	19.949	6.3500	16	0.1963	4.9870	1.5875
1.3299	2.3622	60	19.0986	4.1888	0.7500	19.050	6.0638	16.7552	0.1875	4.7630	1.5160
1.3963	2.2500	57.150	18.1914	4.1998	0.7480	19	6.0479	16.9333	0.1855	4.7120	1.5
1.4111	2.2263	56.549	18	4.2333	0.7421	18.850	6	17.7325	0.1772	4.5	1.4324
1.4508	2.1654	55	17.5070	4.4331	0.7087	18	5.7296	18	0.1745	4.4330	1.4111
1.4784	2.1250	53.975	17.1808	4.5	0.6981	17.733	5.6444	19.9491	0.1575	4	1.2732
1.5	2.0944	53.198	16.9333	4.5696	0.6875	17.463	5.5585	20	0.1571	3.9900	1.2700
1.5708	2	50.800	16.1701	4.6182	0.6803	17.279	5.5	20.3200	0.1546	3.9270	1.25
1.5875	1.9790	50.265	16	4.6939	0.6693	17	5.4113	22.7990	0.1378	3.5	1.1141
1.5959	1.9685	50	15.9155	4.9873	0.6299	16	5.0930	24	0.1309	3.3250	1.0583
1.6755	1.8750	47.625	15.1595	5	0.6283	15.959	5.0800	25	0.1257	3.1920	1.0160
1.6933	1.8553	47.124	15	5.0265	0.6250	15.875	5.0532	25.1327	0.1250	3.1750	1.0106
1.7500	1.7952	45.598	14.5143	5.0800	0.6184	15.708	5	25.4	0.1237	3.1420	1
1.7733	1.7717	45	14.3239	5.3198	0.5906	15	4.7746	26.5988	0.1181	3	0.9549
1.7952	1.7500	44.450	14.1489	5.5	0.5712	14.508	4.6182	28	0.1122	2.8500	0.9071
1.8143	1.7316	43.982	14	5.5851	0.5625	14.288	4.5479	30	0.1047	2.6600	0.8467
1.9333	1.6250	41.275	13.1382	5.6444	0.5566	14.137	4.5	31.4159	0.1	2.5400	0.8085
1.9538	1.6079	40.841	13	5.6997	0.5512	14	4.4563	31.7500	0.0989	2.5130	0.8
1.9949	1.5748	40	12.7324	6	0.5236	13.299	4.2333	31.9186	0.0984	2.5	0.7958
2	1.5708	39.898	12.7	6.1382	0.5118	13	4.1380	32	0.0982	2.4940	0.7938
2.0944	1.5	38.1	12.1276	6.2832	0.5	12.7	4.0425	33.8667	0.0928	2.3560	0.7500
2.0999	1.4961	38	12.0958	6.3500	0.4947	12.566	4	36	0.0873	2.2170	0.7056
2.1167	1.4842	37.699	12	6.5	0.4833	12.276	3.9077	36.2857	0.0866	2.1990	0.7
2.1855	1.4375	36.513	11.6223	6.6497	0.4724	12	3.8197	38	0.0827	2.1	0.6684
2.2166	1.4173	36	11.4592	7	0.4488	11.399	3.6286	39.8982	0.0787	2	0.6366
2.2500	1.3963	35.465	11.2889	7.1808	0.4375	11.113	3.5372	40	0.0785	1.9950	0.6350
2.2848	1.3750	34.925	11.1170	7.2542	0.4331	11	3.5014	42.3333	0.0742	1.8850	0.6
2.3091	1.3605	34.558	11	7.2571	0.4329	10.996	3.5	31.9186	0.0984	2.5	0.7958
2.3470	1.3386	34	10.8225	7.9796	0.3937	10	3.1831	32	0.0982	2.4940	0.7938
2.3936	1.3125	33.338	10.6117	8	0.3927	9.975	3.1750	33.8667	0.0928	2.3560	0.7500
2.4936	1.2598	32	10.1859	8.3776	0.3750	9.525	3.0319	36	0.0873	2.2170	0.7056
2.5	1.2566	31.919	10.1600	8.3996	0.3740	9.5	3.0239	36.2857	0.0866	2.1990	0.7
2.5133	1.2500	31.750	10.1063	8.4667	0.3711	9.425	3	38	0.0827	2.1	0.6684
2.5400	1.2368	31.416	10	8.8663	0.3543	9	2.8648	39.8982	0.0787	2	0.6366
2.6456	1.1875	30.163	9.6010	9	0.3491	8.866	2.8222	40	0.0785	1.9950	0.6350
2.6599	1.1811	30	9.5493	9.2364	0.3401	8.639	2.7500	42.3333	0.0742	1.8850	0.6
2.7500	1.1424	29.017	9.2364	9.3878	0.3346	8.5	2.7056	31.9186	0.0984	2.5	0.7958
2.7925	1.1250	28.575	9.0957	9.9746	0.3150	8	2.5465	32	0.0982	2.4940	0.7938
2.8222	1.1132	28.274	9	10	0.3142	7.980	2.5400	33.8667	0.0928	2.3560	0.7500
2.8499	1.1024	28	8.9127	10.0531	0.3125	7.938	2.5266	36	0.0873	2.2170	0.7056
2.9568	1.0625	26.988	8.5904	10.1600	0.3092	7.854	2.5	36.2857	0.0866	2.1990	0.7
								38	0.0827	2.1	0.6684
								39.8982	0.0787	2	0.6366
								40	0.0785	1.9950	0.6350
								42.3333	0.0742	1.8850	0.6
								48	0.0654	1.6620	0.5292
								50	0.0628	1.5960	0.5080
								50.2655	0.0625	1.5880	0.5053
								50.8	0.0618	1.5710	0.5
								53.1976	0.0591	1.5	0.4775
								63.5	0.0495	1.2570	0.4
								64	0.0491	1.2470	0.3969
								72	0.0436	1.1080	0.3528
								79.7965	0.0394	1	0.3183
								80	0.0393	0.9970	0.3175
								84.6667	0.0371	0.9420	0.3
								96	0.0327	0.8310	0.2646
								120	0.0262	0.6650	0.2117
								127	0.0247	0.6280	0.2



Helical Rack Gauge for Assembling

Module	Code	Dimension	Angle	Rack Code Matched
	Helical Gauge Left Hand			
M1.5	KCHRGH015-Gauge	19*19*200L*M1.5	19°31'42"	KCHRGH015-DIN5 KCHRGH015-DIN6 KMHRG015-DIN6
	KCHRM015-Gauge	17*17*200L*M1.5	19°31'42"	KCHRM015-DIN8 KCHRMQ015-DIN8 KCHRMH015-DIN10
M2	KCHRGH020-Gauge	24*24*200L*M2	19°31'42"	KCHRGH020-DIN5 KCHRGH020-DIN6 KMHRG020-DIN6
	KCHRM020-Gauge	24*24*200L*M2	19°31'42"	KCHRM020-DIN8 KCHRMQ020-DIN8 KCHRMH020-DIN10
M2.5	KCHRGH025-Gauge	24*24*200L*M2	19°31'42"	KCHRGH025-DIN5 KCHRGH025-DIN6 KMHRG025-DIN6
M3	KCHRGH030-Gauge	29*29*200L*M3	19°31'42"	KCHRGH030-DIN5 KCHRGH030-DIN6 KMHRG030-DIN6
	KCHRM030-Gauge	30*A29*200L*M3	19°31'42"	KCHRM030-DIN8 KCHRMQ030-DIN8 KCHRMH030-DIN10
M4	KCHRGH040-Gauge	39*39*200L*M4	19°31'42"	KCHRGH040-DIN5 KCHRGH040-DIN6 KMHRG040-DIN6
	KCHRM040-Gauge	40*A39*200L*M4	19°31'42"	KCHRM040-DIN8 KCHRMQ040-DIN8 KCHRMH040-DIN10
M5	KCHRGH050-Gauge	49*A39*200L*M5	19°31'42"	KCHRGH050-DIN5 KCHRGH050-DIN6 KMHRG050-DIN6
	KCHRM050-Gauge	49*A39*200L*M5	19°31'42"	KCHRM050-DIN8 KCHRMQ050-DIN8 KCHRMH050-DIN10
M6	KCHRGH060-Gauge	59*A49*200L*M6	19°31'42"	KCHRGH060-DIN5 KCHRGH060-DIN6 KMHRG060-DIN6
	KCHRM060-Gauge	59*A49*200L*M6	19°31'42"	KCHRM060-DIN8 KCHRMQ060-DIN8 KCHRMH060-DIN10
M8	KCHRGH080-Gauge	79*79*186.66L*M8	19°31'42"	KCHRGH080-DIN5 KCHRGH080-DIN6 KMHRG080-DIN6
	KCHRM080-Gauge	79*79*186.66L*M8	19°31'42"	KCHRM080-DIN8 KCHRMQ080-DIN8 KCHRMH080-DIN10
M10	KCHRGH100-Gauge	99*99*200L*M10	19°31'42"	KCHRGH100-DIN6 KCHRM100-DIN8
	KCHRM100-Gauge	99*99*200L*M10	19°31'42"	KCHRMQ100-DIN8 KCHRMH100-DIN10





Straight Rack Gauge for Assembling

Module	Code	Dimension	Rack Code Matched
	Straight Gauge		
M1.5	KCSRGH015-Gauge	19*19*197.92L*M1.5	KCSRGH015-DIN 6
	KCSR015-Gauge	17*17*197.92L*M1.5	KCSR015-DIN8 KCSRQ015-DIN8 KCSRMH015-DIN10
M2	KCSRGH020-Gauge	24*24*194.78L*M2	KCSRGH020-DIN5 KCSRGH020-DIN6
	KCSR020-Gauge	25*A24*194.78L*M2	KCSR020-DIN8 KCSRQ020-DIN8 KCSRMH020-DIN10
M2.5	KCSRGH025-Gauge	25*24*196.35L*M2.5	KCSRGH025-DIN6
M3	KCSRGH030-Gauge	29*29*197.92L*M3	KCSRGH030-DIN5 KCSRGH-030-DIN6
M4	KCSRGH040-Gauge	39*39*188.49L*M4	KCSRGH040-DIN5 KCSRGH040-DIN6
	KCSR040-Gauge	40*A39*188.49L*M4	KCSR040-DIN8 KCSRQ040-DIN8 KCSRMH040-DIN10
M5	KCSRGH050-Gauge	49*A39*188.49L*M5	KCSRGH050-DIN5 KCSRGH060-DIN6
	KCSR050-Gauge	49*A39*188.49L*M5	KCSR050-DIN8 KCSRQ050-DIN8 KCSRMH050-DIN10
M6	KCSRGH060-Gauge	59*A49*188.49L*M6	KCSRGH060-DIN6
	KCSR060-Gauge	59*A49*188.49L*M6	KCSR060-DIN8 KCSRQ060-DIN8 KCSRMH060-DIN10

JIS Series noted in gray for easy identification.



Straight Rack Gauge for Assembling

Module	Code	Dimension	Rack Code Matched
	Straight Gauge		
M8	KCSRGH080-Gauge	79*79*175.92L*M8	KCSRGH080-DIN6
	KCSRMO80-Gauge	79*79*175.92L*M8	KCSRMO80-DIN8 KCSRMQ080-DIN8 KCSRMH080-DIN10
M10	KCSRMO100-Gauge	99*99*188.496L*M10	KCSRMO100-DIN8 KCSRMQ100-DIN8 KCSRMH100-DIN10

CP	Code	Dimension	Rack Code Matched
	Straight Gauge		
CP 5	KASRGQ-CP050-GAUGE	15*20*200L*CP5	KMSRGQ-CP050-JIS1 MSTGH-CP050-JIS1
	KCSRMO-CP050-GAUGE	15*20*200L*CP5	KCSRMO-CP050-JIS4
CP 10	KASRGQ-CP100-GAUGE	30*35*200L*CP10	KMSRGQ-CP100-JIS1 KMSRGH-CP100-JIS1
	KCSRMO-CP100-GAUGE	30*35*200L*CP10	KCSRMO-CO100-JIS4
CP 15	KCSRMO-CP150-GAUGE	50*50*195L*CP15	KCSRMO-CP150-JIS4
CP 20	KCSRMO-CP200-GAUGE	60*60*200L*CP20	KCSRMO-CP200-JIS4



Appendix

JIS Series noted in gray for easy identification.



The instruction of installation is adapted for transportation, storage, assembly and maintenance of racks. All the relevant professionals should study carefully the content of the instruction before doing the actions as above. If any professionals don't study thoroughly nor follow up the regulations to do the actions of transportation, storage, assembly and maintenance of racks, any property damage or personal injury, we are irresponsible for any compensations.

OUTLINE OF RACK INSTALLATION INSTRUCTIONS

1. TRANSPORTATION

During transportation process, please do not stack incorrectly, vigorously put or hang racks to make it twisted or damaged.

2. STORAGE

Racks should be stored in dry environment with temperature 25 °C, and relative humidity should be 60% which is the best. To check the rack package should be completed and stored horizontally to avoid being sloping, leaning on one side or upright side.

3. ASSEMBLY

Rack assembly should be operated by well-trained and qualified professionals. Meanwhile, please prepare all the relevant tools accurately while assembling.

4. MAINTENANCES

Please set up maintenance plans based on the running methods of rack and pinions.

**If there are any questions, please kindly contact us.*

RACK INSTALLATION INSTRUCTIONS

1. TRANSPORTATION

All racks are straightened before delivering, and packed by thermal shrinkage film to isolate the air and to protect racks from collision.

If the rack length is over 1,000mm (100cm) or 10 kgs, it should be carried by 2 or more people to avoid collision or dropping.

If carrying plenty of racks, it should be hanged on a pallet to avoid racks dropping. During hanging, please pay attention to the surroundings to avoid dropping or colliding with somethings to injure people.

2. STORAGE

Racks should be stored in a suitable temperate and dry environment. The room temperature should be 25°C, and relative humidity should be 60% which is the best.

Before storage, the rack outside package should be inspected if completed.

Before delivering, all the racks are smeared anti-rust lubricant and packed by thermal shrinkage film to isolate air and prevent from collision. During the rack storage process, it should not be sloping, leaning on one side or upright side.

The rack storage place should be maintained in a suitable and stable temperature and humidity. Meanwhile, the place should be stable to avoid vibration.

Racks should be put on horizontally; prevent from any abnormally stacking, or oppress on the top of racks. So, the racks will not be twisted due to outside oppression.

To check the rack package should be completed and stored horizontally to avoid being sloping, leaning on one side or upright side.



3. ASSEMBLY

3.1 Before assembly, check and prepare.

- 3.1.1 Before assembling racks, please do check the rack outside package and open the cartons carefully in case racks are damaged accidentally.
- 3.1.2. Before assembling racks, please check racks' specifications and all the necessary assembly tools carefully.

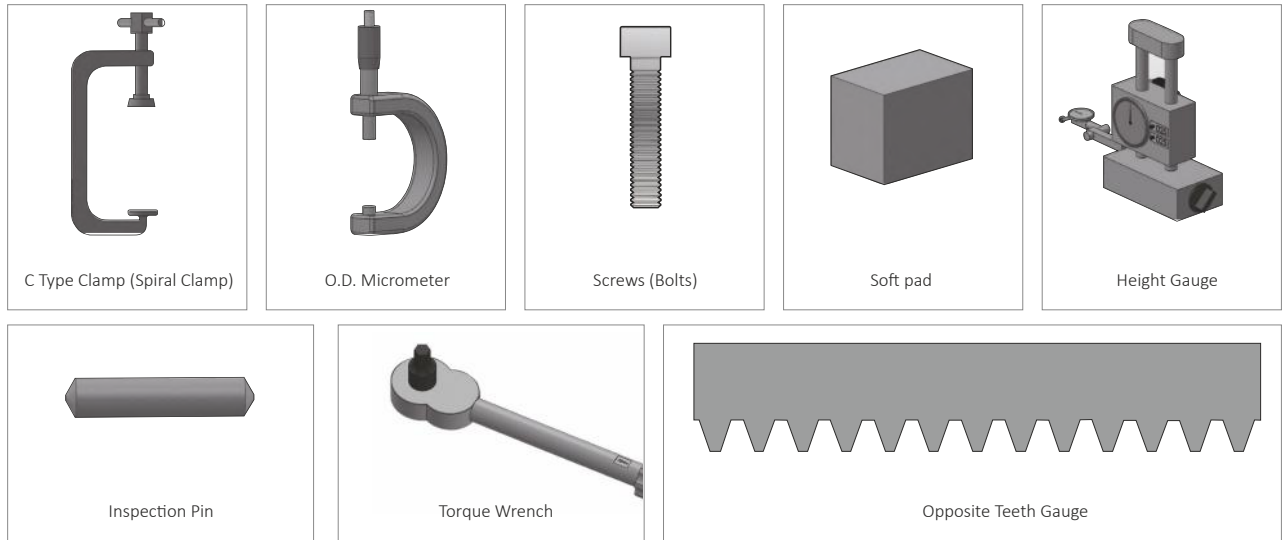

Fig.1

3.1.3 Before assembling, please assure the verticality and parallel of bearing surface of installation basement should be within the tolerance. The verticality is $\leq 0.02\text{mm}$ and parallel is $\leq 0.02\text{mm}$ as the Fig. 2 below.

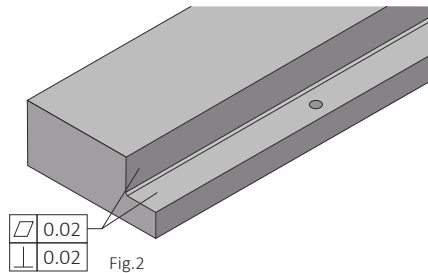

Fig.2

3.1.4 Please do check the bearing surface of rack and installation base clean and complete to avoid any damage or chippings.

3.1.5 The chamfering surface of installation bearing surface bottom have to be aware of the question as Fig 3 noted.



The rack chamfer angle should be apply with our standards (as chart 1). The recommended chamfer value of bearing surface of installation base should not exceed 0.3 mm at maximum.

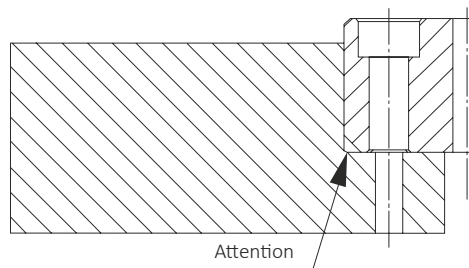
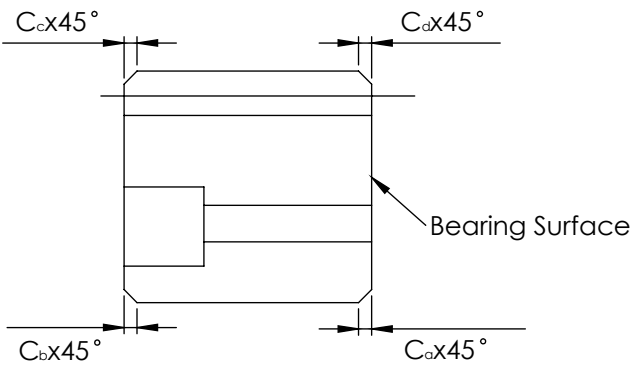

Fig.3



Unit : mm



Rack	Ca	Cb	Cc	Cd
M1	1.5mm	0.5mm	0.5mm	0.5mm
M1.5	1.5mm	0.5mm	0.5mm	0.5mm
M2	2.0mm	1.0mm	1.0mm	1.0mm
M3	2.0mm	1.0mm	1.0mm	1.0mm
M4	2.0mm	1.5mm	1.5mm	1.5mm
M5	3.0mm	1.5mm	1.5mm	1.5mm
M6	3.0mm	2.0mm	2.0mm	2.0mm
M8	4.0mm	2.0mm	2.0mm	2.0mm
M10	5.0mm	3.0mm	3.0mm	3.0mm
M12	5.0mm	3.0mm	3.0mm	3.0mm

Table 1

Appendix

3.1.6 Rack positioning pin hole is specially for quick positioning purpose when racks are assembled repeatedly. If no repeated demands, it is not necessary to assemble positioning pin hole.

3.2. Assembly Process A- Single Rack Assembly

3.2.1 Put the rack on the blocks; put the inspection pin in the rack valley of the teeth and use O.D. micrometer to check the over pin value as Fig 4.

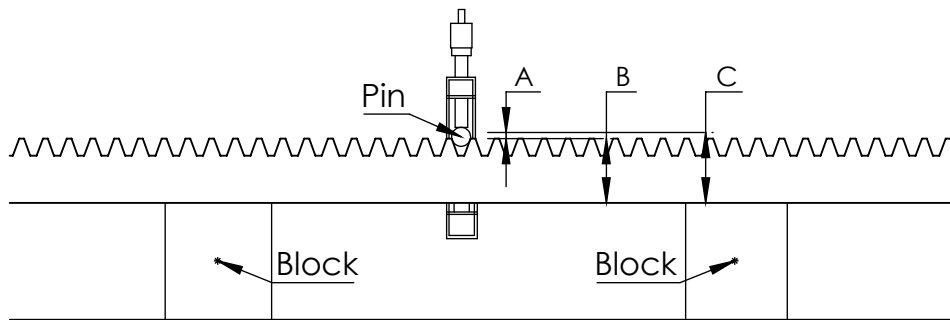

Fig.4

★ Before assembling racks, please refer to the inspection method on Fig. 4 and assure the over-pin values of rack are within the quality grade tolerance.

Over-Pin Value Formula:

Over-Pin Value C= Value A + Total Rack Height B

※ Please refer to Chart 2 for inspection over-pin value.



The best tolerance of inspection pin diameter is $\geq -0.001\text{mm}$.

Unit : mm

Module	Value	Inspection Pin	Pitch	
			Helical (19°31'42")	Straight
M1.0	0.766	ψ2	3.333	3.142
M1.5	1.149	ψ3	5.000	4.712
M2.0	1.532	ψ4	6.667	6.283
M3.0	2.298	ψ6	10.000	9.425
M4.0	3.064	ψ8	13.333	12.566
M5.0	3.830	ψ10	16.667	15.708
M6.0	4.596	ψ12	20.000	18.850
M8.0	6.128	ψ16	26.667	25.133
M10.0	7.659	ψ20	33.333	31.416

Table 2



3.2.2 The rack is put on the top of the base of the bearing surface. Align the screw holes pitches. Slightly tighten the screws to the contact surface of countersunk head screw hole as the Fig. 5 as below.

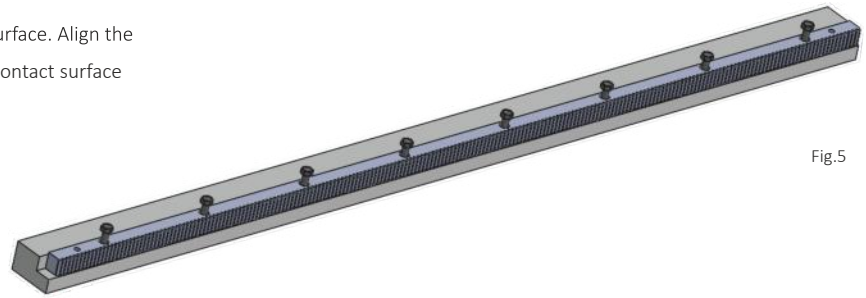

Fig.5

3.2.3 Place the C-type clamp on the soft pad, then fix the two ends of the racks by the C-type clamp. Fix the middle of the rack averagely on the base to assure the whole rack is attached to the bearing surface of the base completed as Fig. 6 below.

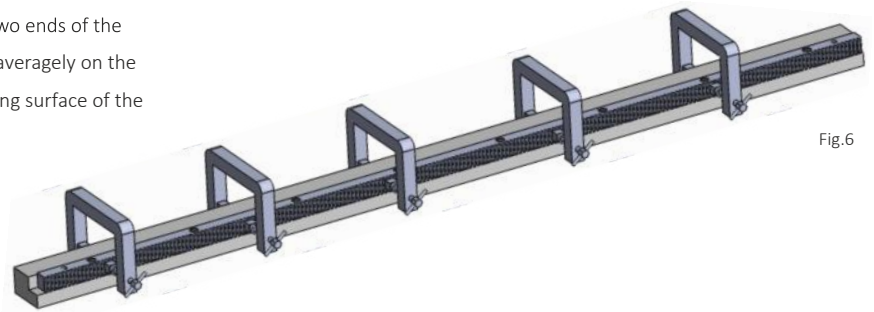

Fig.6

3.2.4 Place inspection pins averagely on the 5 inspection points of the rack. Use height gauge to measure the highest point of the inspection pins. The inspected values should be the same as step 3.2.1. If the values are different, please tighten the C-type clamp and fix the values to the same as step 3.2.1. as Fig. 7 below.

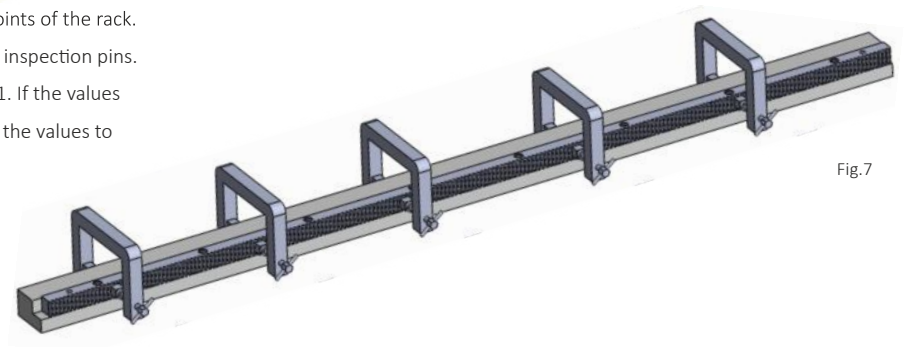

Fig.7

3.2.5 Fix the screws (bolts) from the middle; then onward to the two ends of the racks.

3.2.6 Remove the C-type clamp and soft pads.

3.3. Assembly Process B- Multiple Racks Assembly

3.3.1 Two or more racks assembly, please follow up the assembly process A-single rack assembly. Between racks joint point, it's necessary to increase an assistive device, opposite teeth gauge as the standard of joining racks up, to avoid pitch error too large. (Fig. 8)

Slightly tighten screws and remove opposite teeth gauge as Fig 9, and place the inspection pin on the teeth valley of the joint point (Fig.10). Slightly adjust the jointing two racks and use height gauge to measure the highest point values of the inspection pin(Fig 10/A,B,C points). The values of the three points should be the same as step 3.2.1, using O.D. micrometer to measure. (Fig. 12)

Use C-type clamp and place the soft pads on the rack base. Then, use torque wrench in sequence to fix and tighten screws(bolts). The screw torque values could be referred to Table 3. (Fig. 13) After tightening, remove the inspection pins, C-type clamp and soft pads. The assembly step is completed. (Fig. 14)



Attention Three racks above assembly, it starts from the middle base, and onwards to the ends.



Appendix

3.3.1 Measure the highest point of the inspection pin by height gauge. The measured values should be the same as the values by OD micrometer as step 3.2.1.

3.3.2 The two joint sides should be placed on the assistive device, opposite teeth gauge as the standard of joining racks up. to avoid pitch error too large. (Fig. 8)

3.3.3 Slightly loose screws and remove the opposite teeth gauge. Fig 9.

3.3.4 Place the inspection pins on A, B, C three points. As Fig 10.

3.3.5 Measure the values of the 3 highest points of the inspection pins by height gauge to assure the 3 values are the same as on Step 1. If values are different, slightly adjust the two jointed racks, to make the value of the highest point of inspection pin is the same as step 1. Fig11.

3.3.6 Measure the correct value of the highest inspection pin; use C-type clamp and place soft pads to fix the rack on the base. Then, use torque wrench in sequence to fix and tighten screws as Fig. 12.

3.3.7 Tighten screws and remove C-type clamp, soft pads. The assembly is completed. As Fig 13.

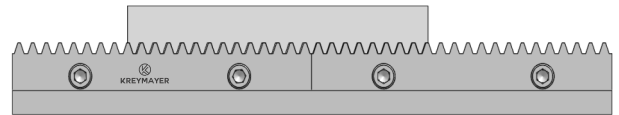

Fig.8

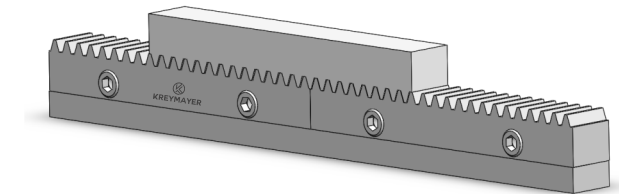

Fig.9

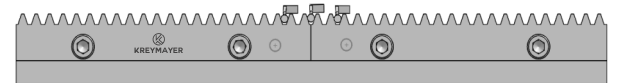

Fig.10

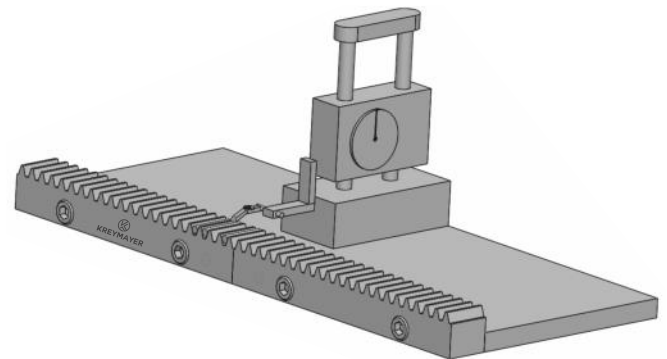

Fig.11

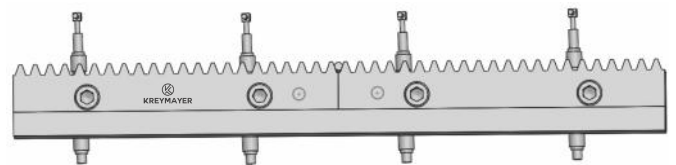

Fig.12

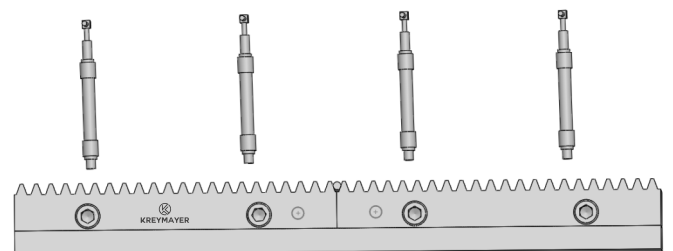

Fig.13



Screw Spec.	Hex Wrench (mm)	Value (N.m)
M4*0.7P	3	4.3
M5*0.8P	4	7.5
M6*1.0P	5	13.4
M8*1.25P	6	30.5
M10*1.5P	8	61
M12*1.75P	10	102
M14*2.0P	12	162
M16*2.0P	14	249
M20*2.5P	17	481
M24*3.0P	19	836
M30*3.5P	22	1670

Table 3. Screw Torque

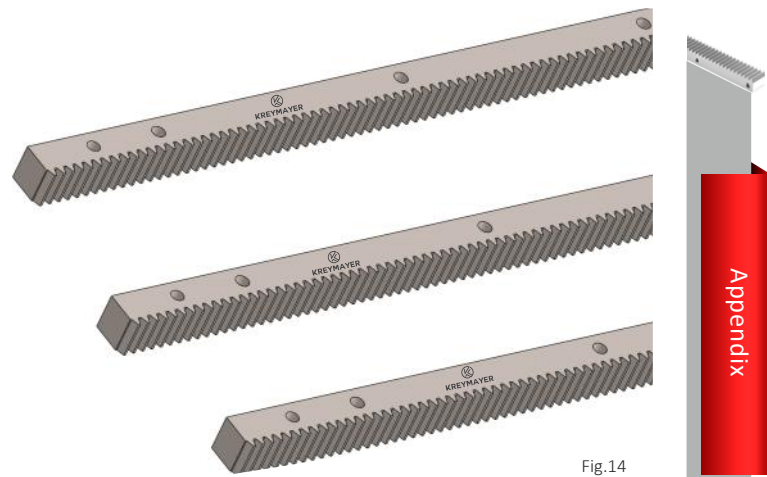

Fig.14



3.4. Inspection After Assembly.

3.4.1 Clean the lubricant oil on the racks.

3.4.2 Smear colored paint on racks such as lead oxide elow powder, red powder and blue powder. (Please use clearable paints).

3.4.3 Inside the rack movement, the pinion runs back and forth to clench.

3.4.4 Observe the peeling situation on the painted teeth of the racks as Fig.14.

3.4.5 If teeth clenches correctly, please clean the colored paint on the racks. Bare parts should be smeared anti-rust lubricant. If not correctly, please adjust it to correct.

3.5. Attentions by Operation

3.5.1 Racks Assembly correct. Teeth clench correct.

3.5.2 The clenching surface of rack and pinion needs lubricant oil.

3.5.3 Assure no people inside the operation area to avoid any injure.

4. Maintenances

4.1 Formulate a maintenance schedule according to the equipment operation situation.

4.2 Please select suitable lubricant oil and decide lubricant system according to the lubricant oil.

4.3 Maintenance cycle should be increased or decreased, based on operation worn situation.

4.4 If racks are worn or damaged seriously, please replace new racks to avoid any impact on operation accuracy and efficiency.

※Rack replacement and maintenance should be operated by trained and qualified professionals.